

# CONSTRUCTION & MINING

SUBMERSIBLE  
DEWATERING PUMPS





## CONSTRUCTION & MINING

### SUBMERSIBLE DEWATERING PUMPS

Tsurumi's submersible pumps are designed and developed along the user's line of sight, which is why they are known for their sound quality, durability, ease of maintenance and a high degree of reliability that enables continuous duty over long periods of use.

As a subcategory thereof, Tsurumi has been manufacturing and selling construction and mine dewatering pumps for over 50 years. Here, repeated bench and field testing under harsh conditions have led to a plethora of technologies and valuable know-how that Tsurumi has used to improve durability and maintainability for the rental, construction and mining markets where severe environments demand nothing short of heavy-duty hardware.

Tsurumi's pumps come in a wide range of sizes from compact packages for household use to midsize and large configurations that better serve construction, tunnel works and mines. Available in an extensive lineup of over 150 pump models of motor outputs (0.1 - 150 kW) and discharge bores (25 - 250 mm), these pumps are suited for a wide range of applications besides general pumping and drainage, including slurries, residues and much more difficult-to-handle media like seawater, high temperature liquids and corrosive liquids. Moreover, Tsurumi has many models capable of turning on/off automatically by way of electrodes or float switches, which contributes to field and environmental management by conserving power and prolonging pump service-life.

Designed in Japan, Tsurumi's submersible pumps come loaded with proprietary technologies tested and proven over the years such as the anti-wicking cable, motor protector, dual inside mechanical seals with silicon carbide faces, Oil Lifter and more. In addition, for the sake of durability, wear-resistant materials are adopted for parts that tend to wear down more easily, paving the way for continuous duty over extended periods of time.

Because of these qualities, Tsurumi's pumps are put to use in a broad range of fields from civil engineering and construction sites that require high reliability to mines and larger scale project sites for tunnels, bridges, dams and so forth, as well as infrastructure for temporarily bypassing sewerage or draining rainwater to avert flooding.



# Performance Range

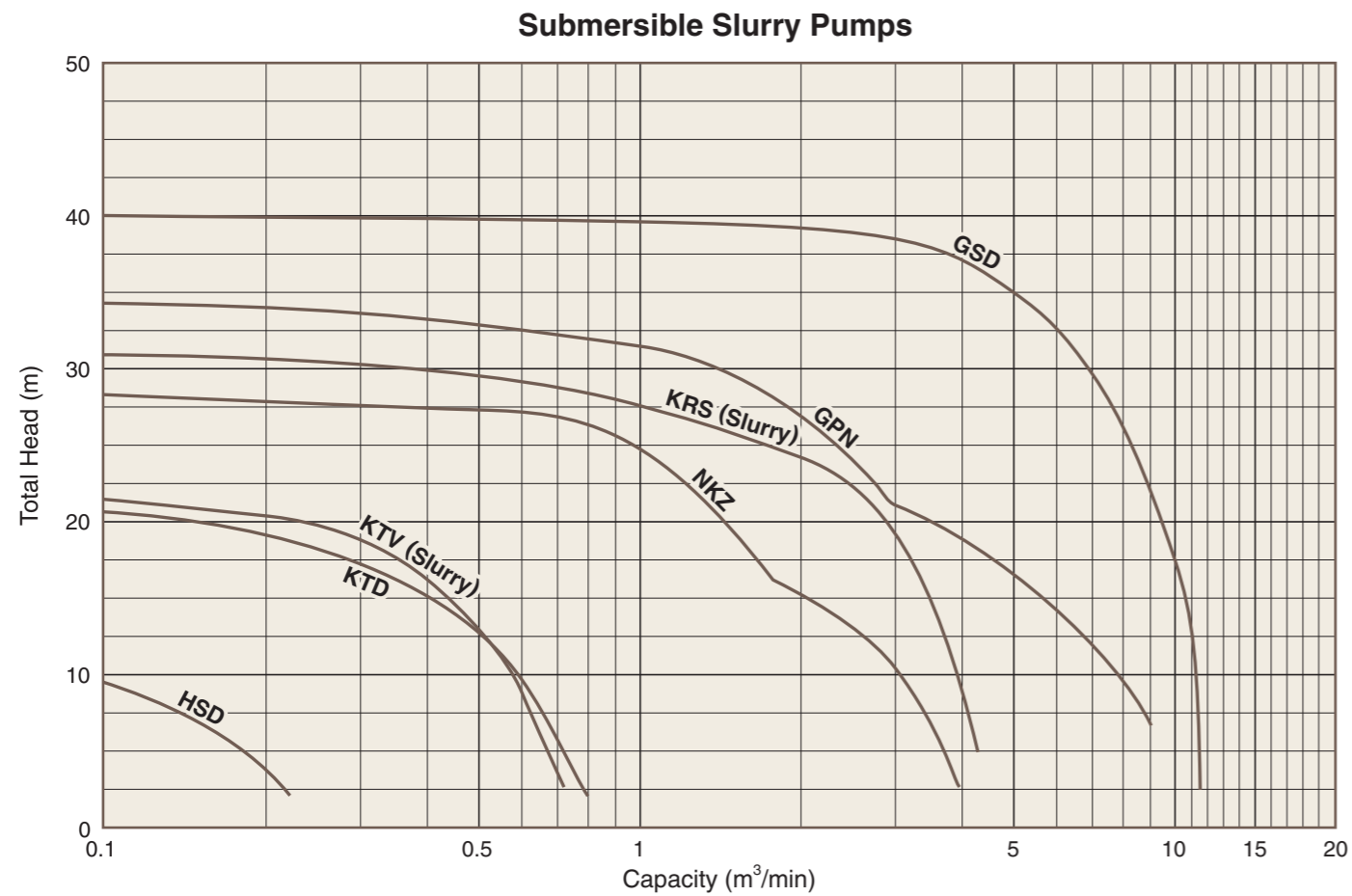
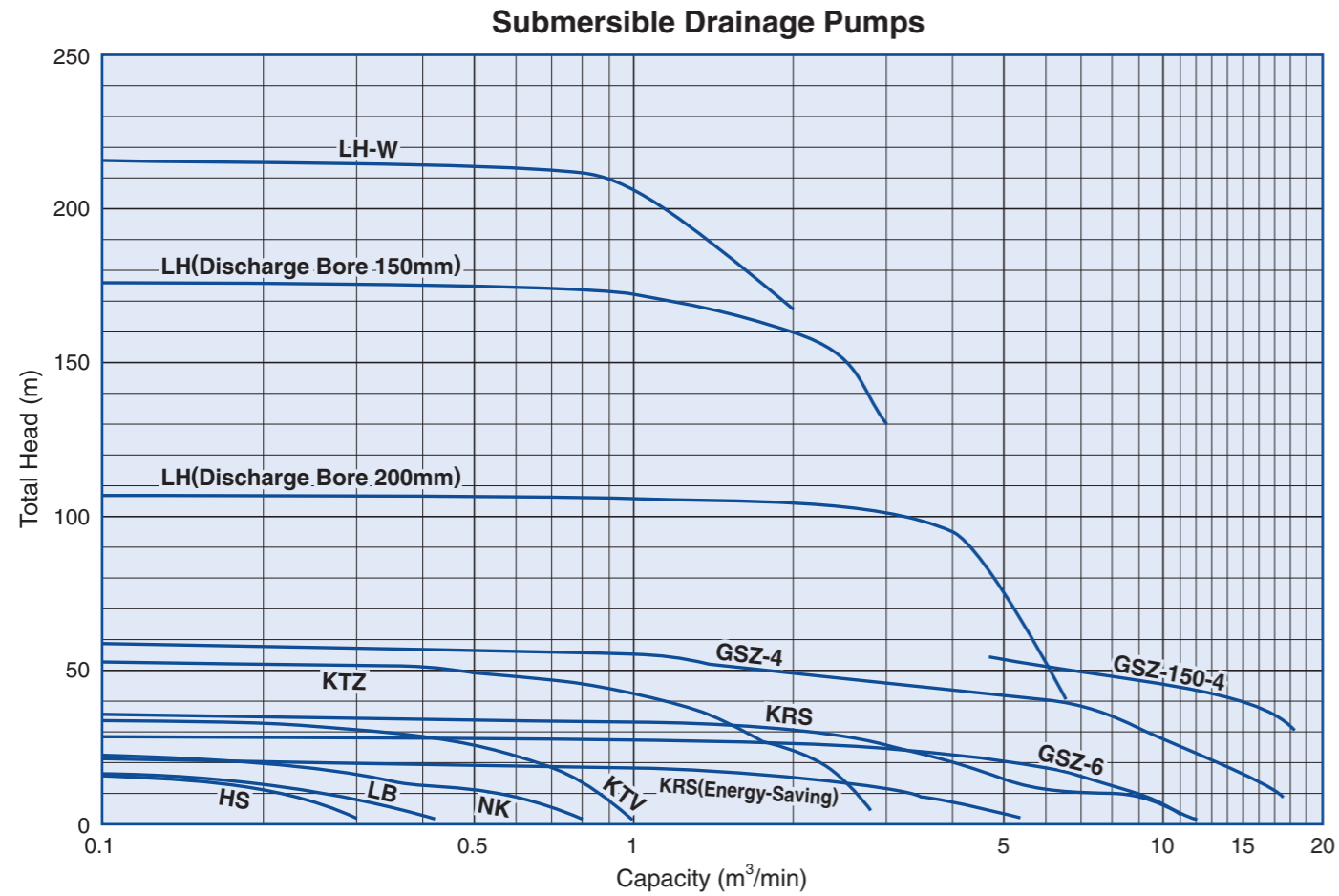

# Selection Table

	Series	Discharge Bore mm	Motor Output kW	No. of Poles	Discharge Design			Agitator	Automatic Operation	
					Top Discharge		Side Discharge			
					Flow-Thru	Side Flow				
Drainage	Small Size	LB / LB-A	50 (80)	0.48 - 1.5	2	●			Electrode (LB-A)	
		HS / HSZ	50 • 80	0.4 • 0.75	2			●	●	Float (HSZ)
		FAMILY / FAMILY-A	15, 25	0.1	2	●				Cylindrical Float (FAMILY-A)
	Medium Size	NK	50 • 80	1.5 • 2.2	2		●			
		KTV / KTVE	50 • 80 (100)	0.75 - 5.5	2		●			Electrode (KTVE)
		KTZ / KTZE	50 - 150	1.5 - 15	2		●			Electrode (KTZE)
	High Head	LH	80 - 200	3 - 110	2	●				
		LH-W	50 - 100	3 - 110	2	●				
		Tandem Operation	50 - 100	3 - 30	2	●				
	High Volume	KRS	80 - 250	2.2 - 22	4	● (KRS1022)	●			
	KRS (Energy-Saving)	100 - 200	3 - 22	4		●				
Sewer Bypass	KRSU	200	22	4		●				
High Head & High Volume	GSZ-4	150 - 250	37 - 150	4			● (Water Jacket)			
High Power	GSZ-6	200	22 • 37	6			● (Water Jacket)			
Slurry	Small Size	HSD	50	0.55	2			●	●	
	Medium Size	KTV (Slurry)	50 • 80 (100)	2 • 3	2		●		●	
		KTD	50 • 80	2 • 3	2		●		●	
		KRS (Slurry)	80 - 200	4 - 18	4		●		●	
		NKZ	80 - 150	2.2 - 11	4			● (Water Jacket)	●	
	High Power	GPN	80 - 200	5.5 - 37	4 • 6			● (Water Jacket)	●	
High Volume	GSD	200 • 250	37 - 75	4			● (Water Jacket)	●		
Corrosion-Resistant	SFQ	50 • 80	0.4 - 11	2			●			
	LH-14 • LH-W-14	80 - 200	11 - 110	2	●					
Residue Drainage	HSR	50	0.4	2			●			
	LSC	25	0.48	2	●					
	LSP	25	0.48	2	●					



\* The cutaway pictures are pumps for the European specifications.  
The pumps of the standard specifications are different shape of a handle and hose coupling.  
Picture of actual pumps, refer to each individual page.

# Structure

## Anti-Wicking Cable Entry

An anti-wicking block is provided at the cable entry section of the motor chamber. Even if the cable jacket becomes damaged or the tip of the cable is accidentally immersed in water, this device prevents water from traveling into the motor chamber through capillary action.

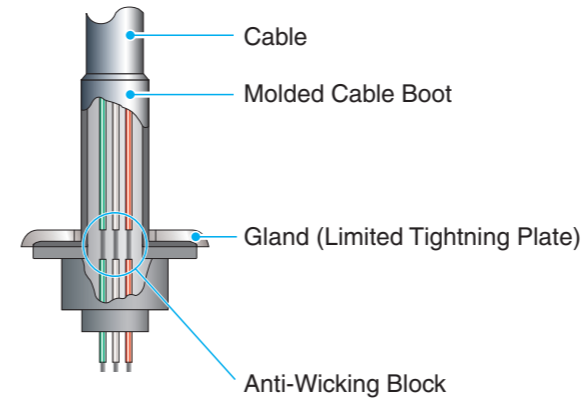

## Dual Inside Mechanical Seal

A dual inside mechanical seal, located in the oil chamber together with the Oil Lifter, has two sealing faces made of quality materials, including silicon carbide (SiC). The advantages of this seal are two-fold; it eliminates spring failure caused by corrosion, abrasion or fouling, which can prevent the seal faces from closing properly, and prevents loss of cooling to the lower seal faces during run-dry conditions, which causes the lower seal faces to fail.

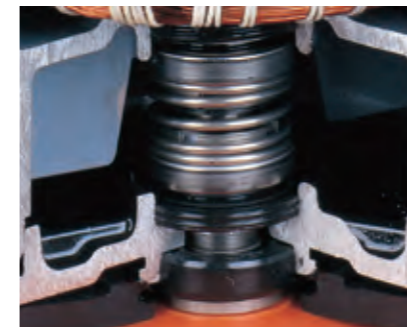

## Automatic Motor Protection Device

A built-in thermal motor protection device reacts to the excessive heat caused by overcurrent or run-dry conditions. It not only cuts off the motor circuit automatically but also resets by itself.



Miniature Thermal Protector

Circle Thermal Protector

## Oil Lifter (Patented)

The Oil Lifter was developed as a lubricating device for the mechanical seal. Utilizing the centrifugal force of the shaft seal, the Oil Lifter forcibly supplies lubricating oil to the upper seal faces even if the lubricant falls below the specified volume. This amazingly simple device reliably lubricates and cools but also stabilizes the effect of the shaft seal and extends the length of the inspection period.

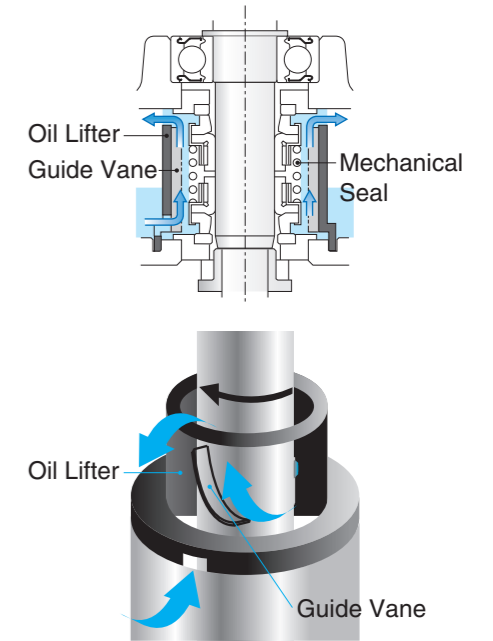

## Bearings

High-grade bearings for high-temperature operation are used. Also, as deep-groove, double-shield ball bearings are used, and as the bearings are permanently lubricated by grease, there is no need for injection of lubricating oil.

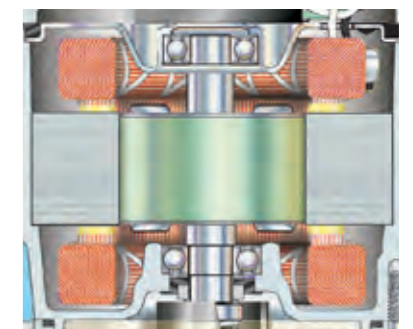

## High-Performance Motor

A motor having stable high performance that meets Tsurumi's high standards of quality is used.

# Feature

## Motor Cooling & Discharge Design

### Top Discharge, Flow-Thru Design

This design provides maximum motor cooling efficiency allowing continuous operation at low water levels and extended dry-run capability, and also allows the shape of the pump to be cylindrical and slim for installation in a well casing for deep well dewatering.

LB LB-A FAMILY FAMILY-A LH LH-W KRS\*  
LH-14 LH-W-14 LSC LSP \*KRS1022 only

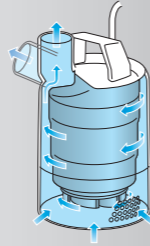

### Side Discharge Design

The pump has a pump casing that facilitates smoother passage of foreign objects in the pumped liquid. It is a simple and practical design that facilitates inspection and repair work.

HS HSZ HSD SFQ HSR

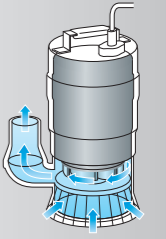

### Top Discharge, Side Flow Design

This design assures efficient motor cooling even if the pump runs with its motor exposed to air, and also allows the overall diameter of the pump to be reduced for installation in confined spaces.

NK KTV KTVE KTZ KTZE KRS\* KRSU  
KTV(Slurry) KTD KRS(Slurry) \*excluding KRS1022

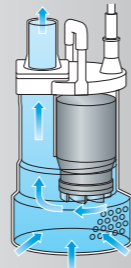

### Side Discharge Design with Water Jacket

The side discharge, spiral design allows smoother passage of the sucked solid matters. The motor is cooled by a water jacket assuring efficient motor cooling even when the pump operates with its motor exposed to air.

GSZ-4 GSZ-6 NKZ GPN GSD

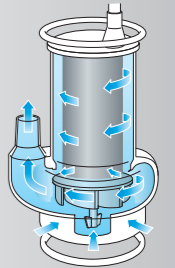

## Automatic Operation

The automatic model only operates when sufficient water is present. It not only reduces power consumption but also extends the life of wear parts of the pump as it eliminates dry-running that causes early wear-out.

### Electrode (LB-A / KTVE / KTZE)

Tsurumi has developed a unique automatic control device utilizing electrodes. The pump stops automatically in about one minute after the water surface falls below the electric probe. Since this mechanism eliminates dry-running, the pump can reduce power consumption by up to 40 percent compared with non-automatic pumps (Tsurumi comparison). It also prevents chattering caused by a turbulent water surface and extends operating life.



### Float Switch (HSZ / FAMILY-A)

This automatic operation system is controlled by a float switch. When the water level rises and raises the float switch to a preset level, the switch turns on, and the pump starts. When the water level lowers to the preset level, pump operation stops.



### Automatic Operation (LB-A / KTVE / KTZE)

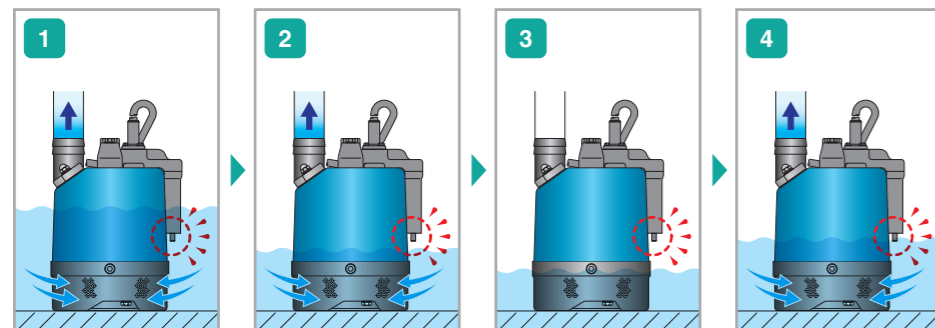

1 Pump continues to run while the electric probe remains submerged.  
2 When the water surface falls below the electric probe, timer starts to count about one minute.  
3 Pump stops in about one minute after the water level falls.  
4 When the water level rises to contact the electric probe, pump starts operating again.

Optional Accessory

#### Extension Probe x 2

Electric Probe  
Extension Probe  
Cuttable to Desired Length

It is possible to set a lower starting water level by using an extension probe (optional accessory). The starting water level is adjustable because the extension probe can be cut to the desired length as it is made of coil spring.

### Automatic Operation (HSZ)

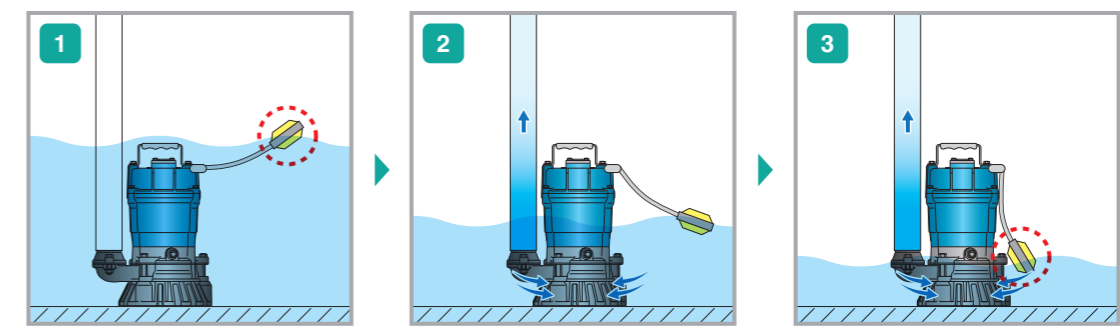

1 Pump starts operating when the water level rises to a preset level.  
2 Pump keeps running while the float switch remains on.  
3 When the water level lowers to the preset level, pump stops operating.

The process is repeated.

Single-phase Portable Drainage Pumps

# LB LB-A



LB LB-A

(LB-A : Automatic pump with electrode)

Model		Discharge Bore mm	Motor Output kW	Dry Weight kg	Dimensions mm	
Manual	Automatic				L	H
LB-480	LB-480A	50	0.48	11.0	223	286
LB-800	LB-800A	50(80)	0.75	13.7	223	341
LB-1500	—	50(80)	1.5	33	187	593

- Tsurumi typical pumps
- Multi-directional hose coupling (vertical and inclined)
- Automatic model with electrode type relay unit [LB-A]

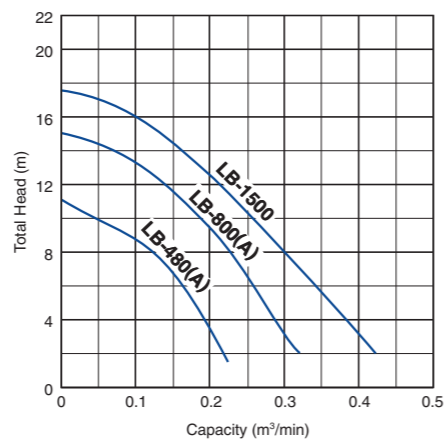

Single-phase Portable Drainage Pumps

# HS HSZ



HS HSZ

(HSZ : Automatic pump with float)

Model		Discharge Bore mm	Motor Output kW	Dry Weight kg	Dimensions mm	
Manual	Automatic				L	H
HS2.4S	HSZ2.4S	50	0.4	11.3	241	328
HS2.75S	HSZ2.75S	50	0.75	16.4	285	394
HS3.75S	HSZ3.75S	80	0.75	16.8	285	394

- Multi-field use pumps with agitator
- Automatic model with single float switch [HSZ]

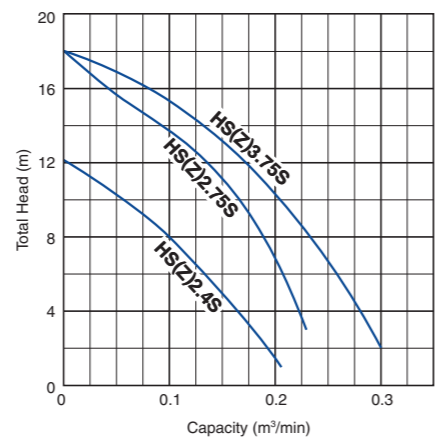

Single-phase Portable Drainage Pumps

# FAMILY FAMILY-A



FAMILY FAMILY-A Residue Adapter

(FAMILY-A : Automatic pump with float)

Model		Discharge Bore mm	Motor Output kW	Dry Weight kg	Dimensions mm	
Manual	Automatic				L	H
FAMILY-12	FAMILY-12A	15, 25	0.1	3.6	201	256

- Suitable for domestic use
- Automatic model with cylindrical float switch [FAMILY-A]
- Drain water to 1 mm in depth by attaching optional residue adapter [FAMILY]

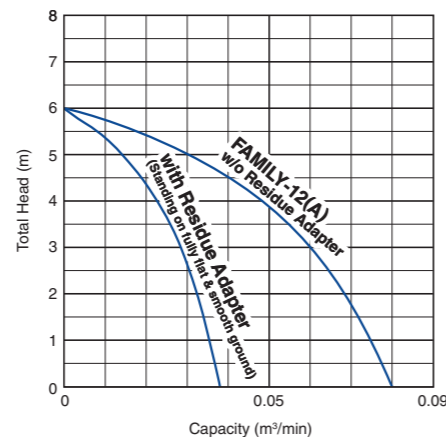

Single-phase Portable Drainage Pumps

# NK



Model	Discharge Bore mm	Motor Output kW	Dry Weight kg	Dimensions mm	
				L	H
NK3-15	50	1.5	29	243	614
NK4-22	50	2.2	29	243	614
NK3-22L	80	2.2	40	236	669

- Larger output motor
- Durability equivalent to three-phase drainage pumps

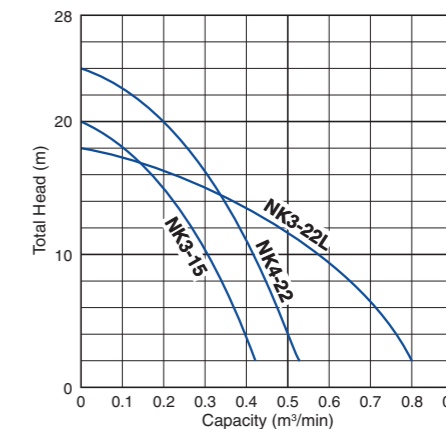

Three-phase Portable Drainage Pumps

# KTV KTVE



KTV KTVE

(KTVE : Automatic pump with electrode)

Model		Discharge Bore mm	Motor Output kW	Dry Weight kg		Dimensions mm		
Manual	Automatic			Manual	Automatic	L	H	
KTV2-8	KTVE2.75	50	0.75	11.5	12.7	200	369	417
KTV2-15	KTVE21.5	50(80)	1.5	21.0	22.0	240	392	462
KTV2-22	KTVE22.2	50(80)	2.2	23.0	25.0	240	412	462
KTV2-37H	—	50	3.7	36.0	—	285	510	—
KTV2-37	KTVE33.7	80(100)	3.7	36.0	40.0	285	510	585
KTV3-55	KTVE35.5	80(100)	5.5	47.0	52.0	300	545	620

- Lightweight compact pumps made of die-casted aluminium alloy
- Automatic model with electrode type relay unit [KTVE]

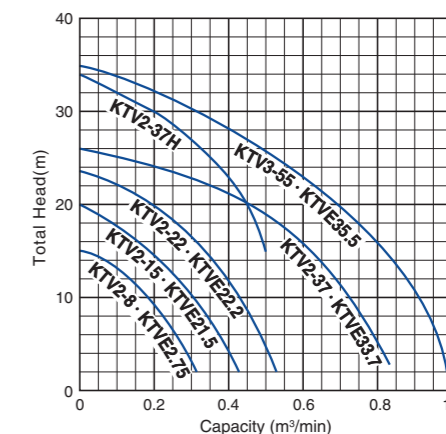



Extra High Head Drainage Pumps by Tandem

# Tandem Operation -LH·LH-W-



“Tandem operation” is an operation method that connects two pumps of the same model in series. This provides double pump head at the same flow rate in comparison with that of a single pump. The principle of tandem operation is the same as that with multistage pumps.

Model	Discharge Bore mm	Motor Output kW	Dry Weight kg	Dimensions mm	
				L	H
LH33.0	80	3	54	185	731
LH23.0W	50	3	59	185	759
LH25.5W	50	5.5	96	254	808
LH311W	80	11	125	270	1043
LH322W	80	22	365	330	1255
LH430W	100	30	389	365	1400

The intermediate connection pipe is not required in the range indicated as a bold line on curves. If the required total head exceeds the maximum head of the pump without an intermediate connection pipe (indicated as dashed line), an intermediate connection pipe of a length corresponding to the excess amount or more is required.

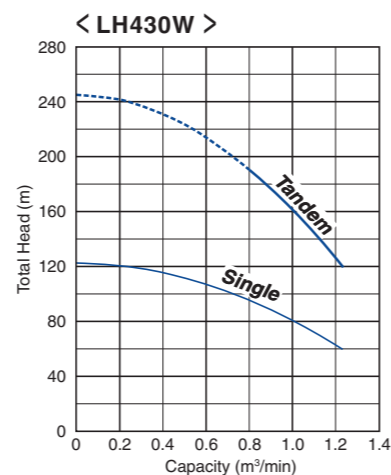
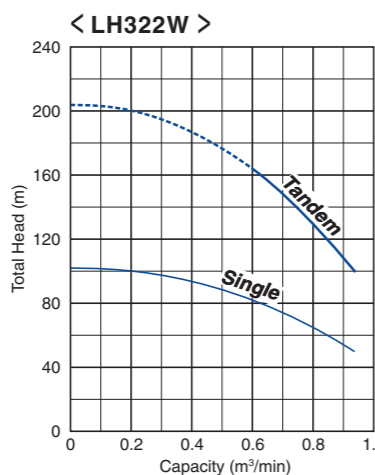
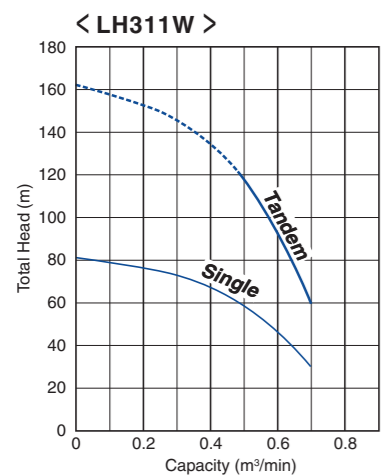
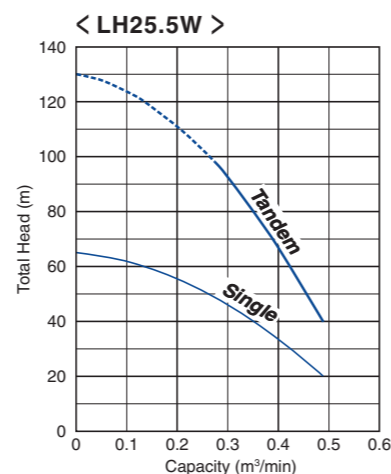
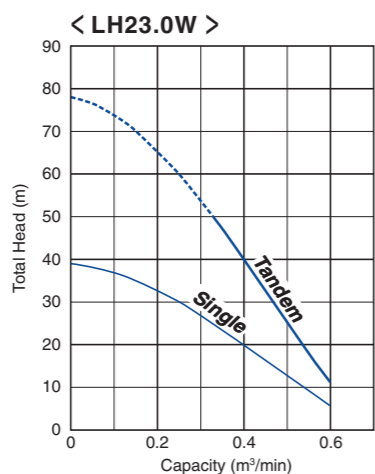
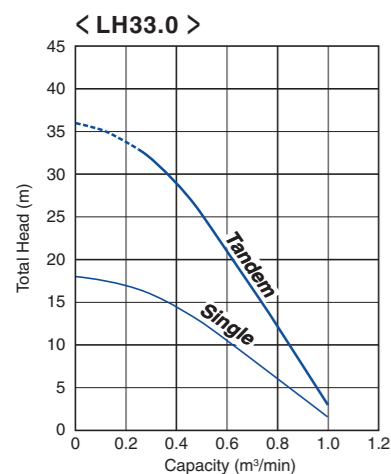

High Volume Drainage Pumps

# KRS



Model	Discharge Bore mm	Motor Output kW	Dry Weight kg	Dimensions mm	
				L	H
KRS2-C3/A3	80	2.2	72	340	619
KRS2-D3/B3	80	3.7	91	362	704
KRS2-C4/A4	100	3.7	88	349	719
KRS2-D4/B4	100	5.5	98	362	709
KRS2-C6/A6	150	7.5	130	415	767
KRS2-D6/B6	150	11	158	434	813
KRS2-8S	200	11	174	472	933
KRS815	200	15	240	481	1069
KRS819	200	18.5	360	576	1241
KRS822	200	22	380	576	1241
KRS822L	200	22	380	576	1241
KRS1022	250	22	390	525	1419

- General-purpose heavy-duty cast iron pumps
- Suitable for high volume pumping

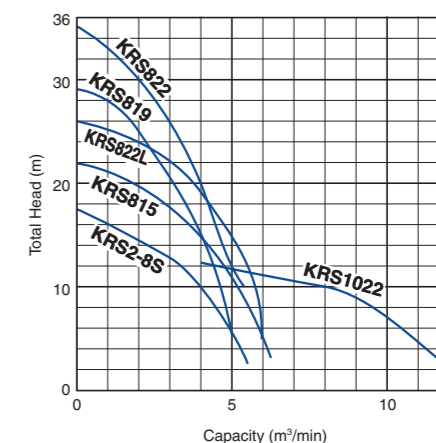
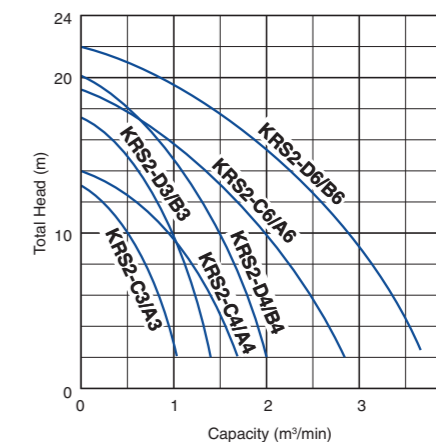

High Volume Drainage Pumps

# KRS (Energy-Saving)



Model	Discharge Bore mm	Motor Output kW	Dry Weight kg	Dimensions mm	
				L	H
KRS-43	100	3	95	378	723
KRS-63	150	3	97	384	866
KRS-65.5	150	5.5	118	425	790
KRS2-69	150	9	155	490	812
KRS-85.5	200	5.5	126	446	941
KRS2-89	200	9	175	473	933

- General-purpose heavy-duty cast iron pumps
- Energy-saving type of low output and low head reduces power consumption

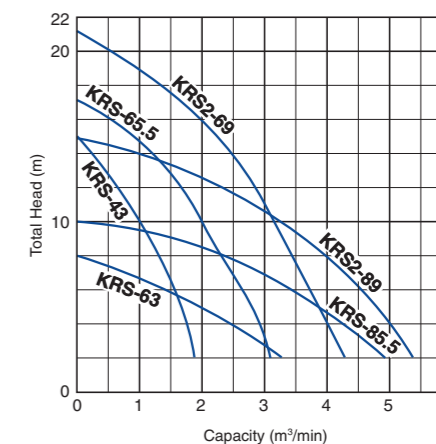

Submersible Pump for Sewage Bypass

# KRSU



- Submersible pump for provisional sewage bypass between manholes
- Suitable for temporarily bypassing drainage in sewer construction work

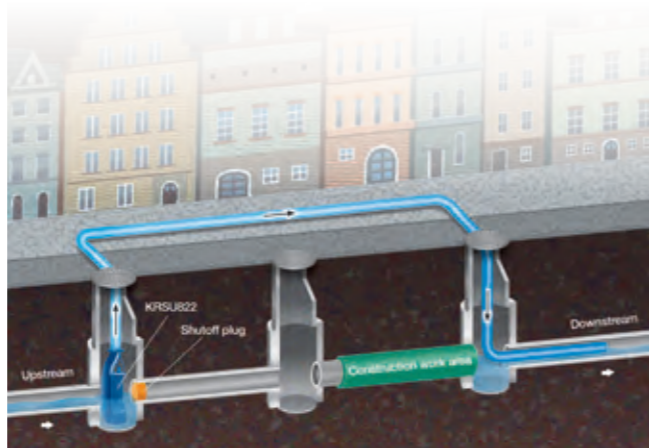
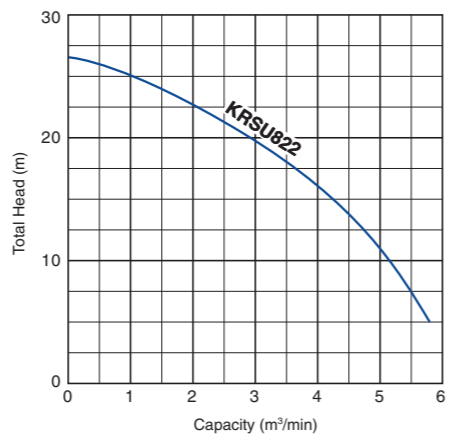

It is not recommended to operate the unit continuously along the dashed curve.

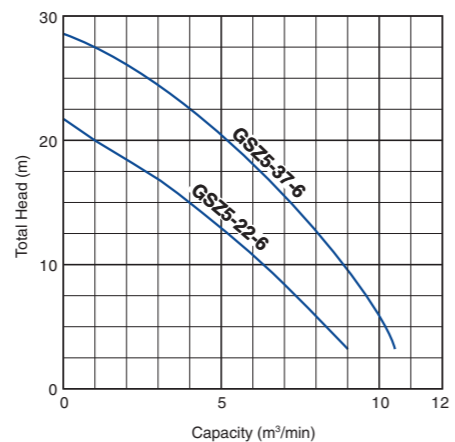
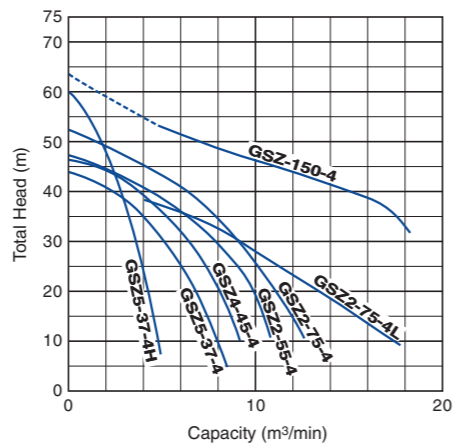

Model	Discharge Bore mm	Motor Output kW	Dry Weight kg	Dimensions mm	
				L	H
KRSU822	200	22	430	546	1486

High Head & High Volume Drainage Pumps

# GSZ-4



- Heavy-duty high head, high volume drainage pumps with internal 4 pole motor
- Water jacket for forcibly cooling the motor at low water level

Model	Discharge Bore mm	Motor Output kW	Dry Weight kg	Dimensions mm	
				L	H
GSZ5-37-4H	150	37	595	900	1553
GSZ5-37-4	200	37	566	915	1583
GSZ4-45-4	200	45	583	915	1591
GSZ2-55-4	250	55	1091	1050	1927
GSZ2-75-4	250	75	1141	1050	1927
GSZ2-75-4L	250	75	1200	1050	1972
GSZ-150-4	250	150	2315	1218	2420

High Volume Drainage Pumps

# GSZ-6



- Heavy-duty high volume drainage pumps with internal 6 pole motor
- Capable of discharging slurries laden with silt, earth, sand or other particulate
- Water jacket for forcibly cooling the motor at low water level

Model	Discharge Bore mm	Motor Output kW	Dry Weight kg	Dimensions mm	
				L	H
GSZ5-22-6	200	22	685	965	1360
GSZ5-37-6	200	37	796	1047	1421

Single-phase Portable Slurry Pump

# HSD



Model	Discharge Bore mm	Motor Output kW	Dry Weight kg	Dimensions mm	
				L	H
HSD2.55S	50	0.55	14	241	391

- Equipped with high-chromium cast iron impeller and agitator

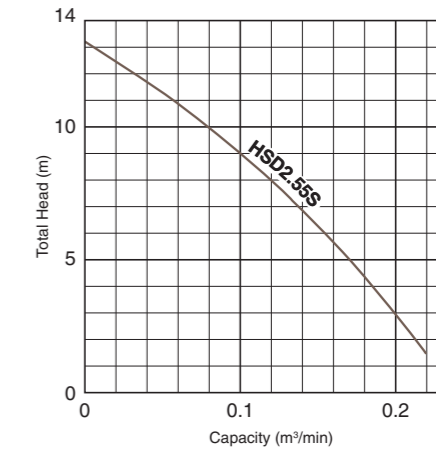

Three-phase Portable Slurry Pumps

# KTV (Slurry)



Model	Discharge Bore mm	Motor Output kW	Dry Weight kg	Dimensions mm	
				L	H
KTV2-50	50(80)	2	25	250	450
KTV2-80	80(100)	3	38	295	550

- Lightweight compact pumps made of die-casted aluminium alloy
- Equipped with high-chromium cast iron impeller and ductile cast iron agitator

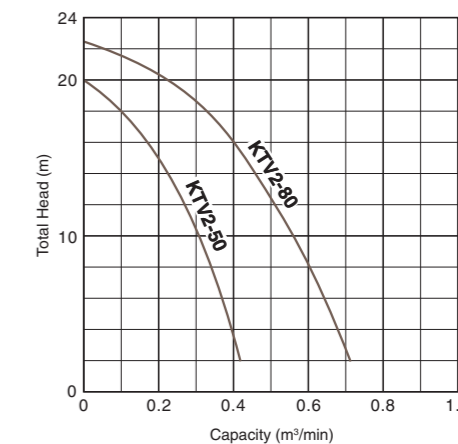

Three-phase Portable Slurry Pumps

# KTD



Model	Discharge Bore mm	Motor Output kW	Dry Weight kg	Dimensions mm	
				L	H
KTD22.0	50	2	38	235	550
KTD33.0	80	3	65	297	644

- Heavy-duty cast iron pumps
- Equipped with high-chromium cast iron impeller and ductile cast iron agitator

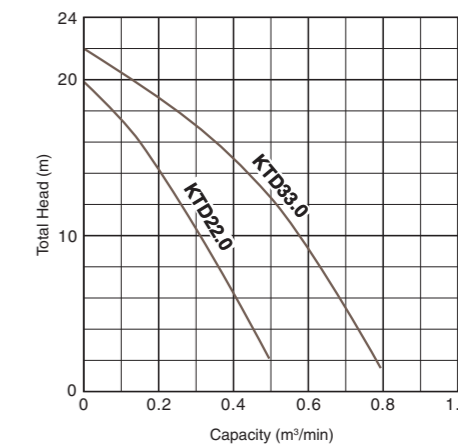

Slurry Pumps

# KRS (Slurry)



- Heavy-duty cast iron pumps
- Equipped with high-chromium cast iron impeller and agitator

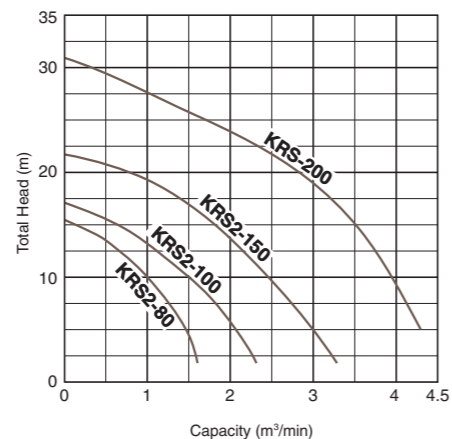

Model	Discharge Bore mm	Motor Output kW	Dry Weight kg	Dimensions mm	
				L	H
KRS2-80	80	4	105	349	800
KRS2-100	100	6	143	415	835
KRS2-150	150	9	170	433	898
KRS2-200	200	18	380	576	1181

Slurry Pumps

# NKZ



- Wide product lineup with agitator
- Water jacket for forcibly cooling the motor at low water level

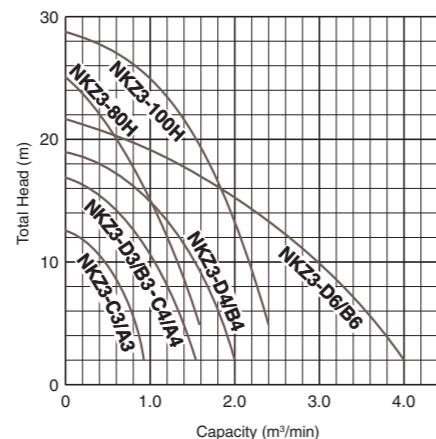

Model	Discharge Bore mm	Motor Output kW	Dry Weight kg	Dimensions mm	
				L	H
NKZ3-C3/A3	80	2.2	91	467	664
NKZ3-D3/B3	80	3.7	100	467	709
NKZ3-80H	80	5.5	132	491	754
NKZ3-C4/A4	100	3.7	97	467	709
NKZ3-D4/B4	100	5.5	115	485	715
NKZ3-100H	100	11	196	547	841
NKZ3-D6/B6	150	11	192	620	798

High Power Slurry Pumps

# GPN



- High powered heavy-duty slurry pumps with internal 4 or 6 pole motor
- Chromium molybdenum steel shaft suitable for strong slurry
- Equipped with high-chromium cast iron impeller, suction plate and agitator
- Water jacket for forcibly cooling the motor at low water level

Model	Discharge Bore mm	Motor Output kW	Dry Weight kg	Dimensions mm	
				L	H
GPN35.5	80	5.5	145	487	796
GPN411	100	11	217	617	879
GPN415	100	15	220	617	879
GPN422	100	22	415	725	1102
GPN622	150	22	415	725	1102
GPN837	200	37	800	1015	1606

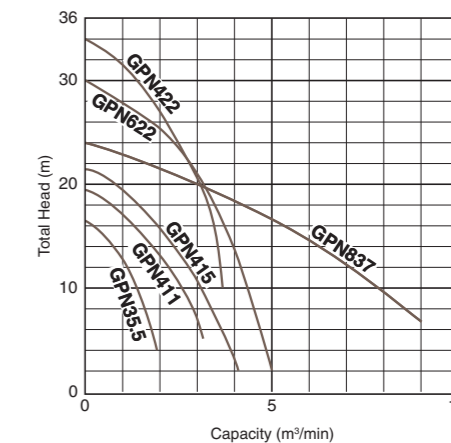

High Volume Slurry Pumps

# GSD



- Heavy-duty high head, high volume slurry pumps with internal 4 pole motor
- Equipped with high-chromium cast iron impeller and agitator

Model	Discharge Bore mm	Motor Output kW	Dry Weight kg	Dimensions mm	
				L	H
GSD-37-4	200	37	685	915	1583
GSD-55-4	250	55	1100	1050	1927
GSD-75-4	250	75	1215	1050	1927

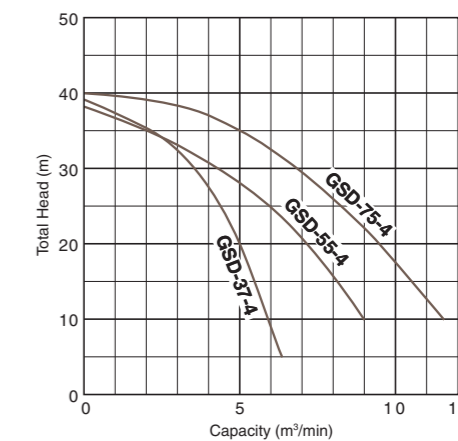

Corrosion-resistant Pumps

# SFQ

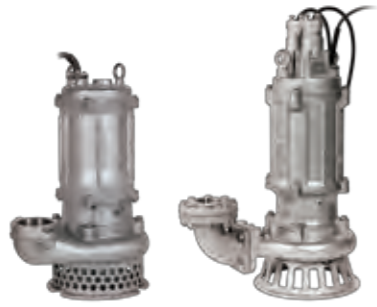

Model	Discharge Bore mm	Motor Output kW	Dry Weight kg	Dimensions mm	
				L	H
50SFQ2.4S	50	0.4	21	252	427
50SFQ2.4	50	0.4	20	252	398
50SFQ2.75	50	0.75	22	252	398
80SFQ21.5	80	1.5	36	329	484
80SFQ23.7	80	3.7	52	359	542
80SFQ25.5	80	5.5	124	635	844
80SFQ27.5	80	7.5	123	635	844
80SFQ211	80	11	143	635	892

- Corrosion-resistant pumps made of 316 stainless steel casting
- Suitable for acidic, chemical fluids of low pH value
- Available on guide rail fitting system

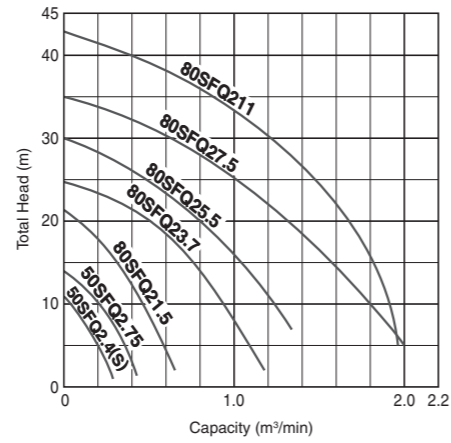

High Head Corrosion-resistant Pumps

# LH-14 LH-W-14



LH-14

LH-W-14

Model	Discharge Bore mm	Motor Output kW	Dry Weight kg	Dimensions mm	
				L	H
LH422-14	100	22	370	420	1352
LH637-14	150	37	540	530	1448
LH6110-14	150	110	1350	592	1887
LH837-14	200	37	540	530	1488
LH8110-14	200	110	1400	592	1887
LH311W-14	80	11	320	330	1184
LH322W-14	80	22	340	330	1275

- Corrosion-resistant pumps made of 316 stainless steel casting
- Suitable for acidic, chemical fluids of low pH value
- Available in single impeller [LH-14] or dual impellers [LH-W-14]

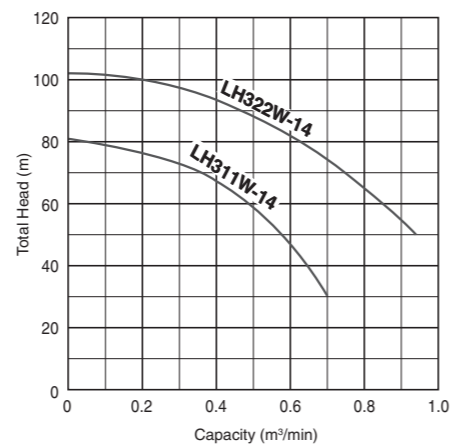
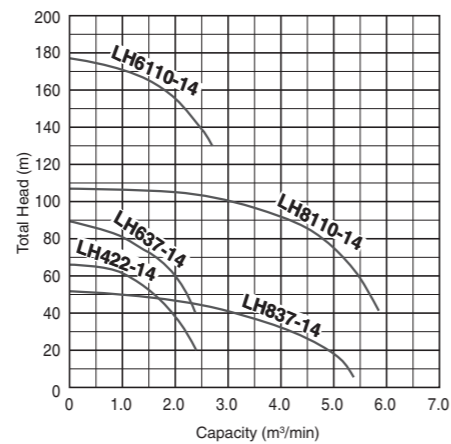

Single-phase Portable Residue Drainage Pump

# HSR



Model	Discharge Bore mm	Motor Output kW	Dry Weight kg	Dimensions mm	
				L	H
HSR2.4S	50	0.4	10.8	227	282

- Suitable for draining shallow standing water
- Drain water to 1 mm in depth
- Multi-directional hose coupling (vertical and inclined)

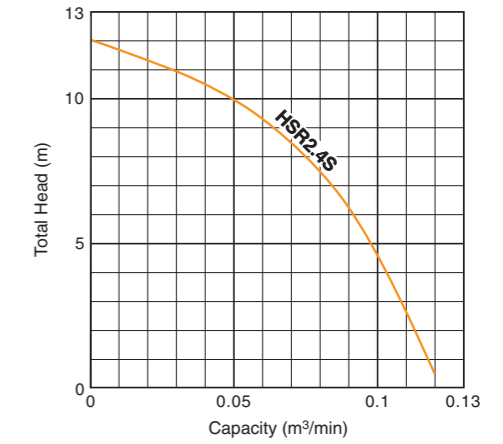

Single-phase Portable Residue Drainage Pump

# LSC



Model	Discharge Bore mm	Motor Output kW	Dry Weight kg	Dimensions mm	
				L	H
LSC1.4S	25	0.48	12	196	316

- Suitable for draining shallow standing water
- Drain water to 1 mm in depth
- Multi-directional hose coupling (vertical and inclined)
- Swing check valve prevents reverse-flow

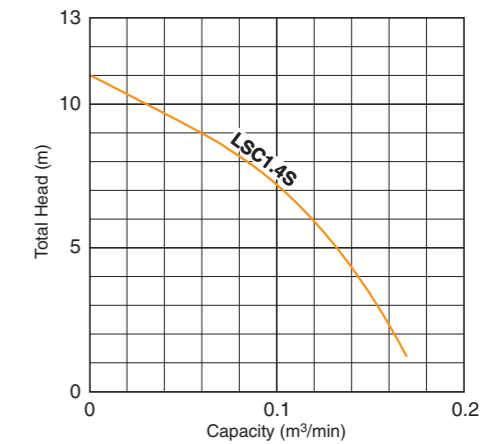

Single-phase Portable Self-priming Residue Drainage Pump

# LSP



Model	Suction & Discharge mm	Motor Output kW	Dry Weight kg	Dimensions mm	
				L	H
LSP1.4S	25	0.48	16.5	300	307

- Suitable for draining shallow standing water
- Can drain water at narrow space by free-positioning suction attachment
- Syphon breaker mechanism prevents reverse-flow

Tsurumi offers a series of pumps for low level standing water, which can suck up and drain a small volume of stagnant or residual water. With a compact and lightweight design, these pumps provide excellent portability. Also, because they run on a single-phase power supply, these pumps are easy to handle. Various types of pumps are available in our product lineup: some models can drain water to a minimum level of 1 mm, while others are equipped with a water reverse-flow preventing mechanism or a suction attachment. These pumps are suitable for draining shallow standing water, for example, draining water on the floor of construction sites, pits, water collection/feed tanks and small puddles, by taking advantage of the characteristics of each model.

Recently, the Zika virus, which threatens to go global, and Dengue fever, which induces a high fever, have been prevalent in tropical and subtropical zones of South East Asia and elsewhere. Tsurumi's residue drainage pumps can smoothly drain standing water where disease-carrying mosquitoes breed. Eliminating standing water is the most significant countermeasure against infection of the above diseases, as it prevents mosquitoes from breeding.



## Anti Zika and Dengue Prevent Mosquito Breeding

Drain water to 1mm

### HSR



Can pump water as shallow as 5mm from the bottom of the pump and drain water to 1mm in depth.

### FAMILY option



Residue Adapter

Attaching the optional residue adapter to the pump casing allows draining to 1mm in depth.

Drain water to 1mm, prevent reverse-flow

### LSC



Can drain water to 1mm in depth. A valve seat and swing check valve prevent suctioned water from backflowing.

Portable suction attachment, prevent reverse-flow

### LSP



Can pump pooled water from shallow recesses using the suction attachment. A new syphon breaker mechanism prevents backflowing and the seal water from draining out.

## Options

### Seawater-Resistant Version

Tsurumi's pumps can be combined with a seawater-resistant kit (optional) that adds a "galvanic anode" and "seawater-resistant special cast iron impeller," and enables about two years of service. (The service period depends on operating conditions.)



Conversion to  
Seawater-Resistant Pump



### High Temperature Liquids Version

Tsurumi's pumps are applicable to high temperature liquids of up to 90°C. Pumps of the standard specification can discharge liquids of up to 40°C. However, there are many fields that need to discharge higher temperature liquids, e.g., discharging industrial water from a power plant or ironworks, or discharging hot spring water from a mine in a volcanic zone.



### Corrosion-Resistant Version

Tsurumi's pumps can be fabricated with all fluid-contacting parts made of 316 stainless steel, including the impeller, pump casing, motor frame, outer cover, strainer stand, and flange/hose coupling.



### High Voltage Version

Tsurumi's pumps can be fabricated to 690V or 1000V ratings that are often required for mining applications. The pumps meet mining safety standards as they come with shielded cables and motors with built-in diodes for ground-fault checks.

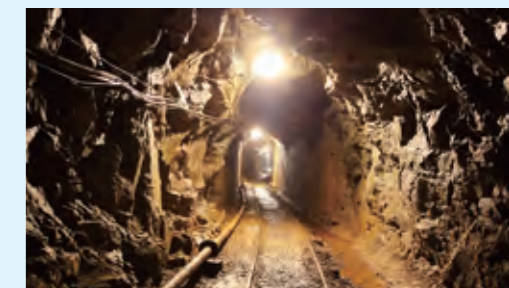



We reserve the right to change the specifications and designs for improvement without prior notice.

**TSURUMI  
MANUFACTURING CO., LTD.**

Your Dealer