



Makita[®]

2018

PRODUCT CATALOGUE

Index



Category		CG100D		52		DHR165		29		DUB362		94		GA5040R		69		HR5212		63	
Cordless Tools 18V x 2	13	CL106FD		53	DHR171		28	DUC254	new	39	GA7020		69	HS0600		77					
Cordless Tools 18V	23	CL107FD		53	DHR202		29	DUC254	new	89	GA7030		70	HS7010		76					
Cordless Tools 12V CXT	43	CL183D		42	DHR241		29	DUC353		17	GA7040S		70	HS7600		76					
Cordless Tools 10.8V, 7.2V & 3.6V	58	CLX201		50	DHR242		28	DUC353		89	GA7050		69	HW102		97					
Drilling / Fastening	59	CP100D		51	DHR280	new	19	DUH551	new	22	GA7050R01		69	HW111		97					
Impact Drilling / Demolition	61	DA3010F		59	DHR282	new	19	DUH551	new	92	GA7060		70	HW1200		96					
Cutting	65	DA332D		49	DHS630		32	DUH651	new	22	GA7060R		70	HW121		97					
Grinding / Sanding	67	DA333D		49	DHS660	new	32	DUH651	new	92	GA7061		70	HW1300		96					
Sawing	75	DA4031		59	DHS661	new	32	DUM168		95	GA7061R		70	JN1601		67					
Planing / Routers	78	DBM131		59	DHS780	new	19	DUM604		39	GA7062		70	JN3201		67					
Dust Extraction / Others	79	DBM230		59	DJR186		32	DUP361		22	GA7063R		70	JR103D		52					
Pneumatic Tools	80	DCF102	new	41	DJR188		32	DUP361		95	GA9020		70	JR3050T		66					
maktec	81	DCG180		38	DJR360	new	19	DUR182		39	GA9030		71	JR3070CT		66					
Outdoor Power Equipment	82	DCL180		38	DLM460	new	22	DUR182		86	GA9040S		71	JS1601		66					
MT Series	99	DCL182		38	DLM460	new	86	DUR187	new	39	GA9050		70	JS1602		66					
		DCL501		38	DLS111		19	DUR187	new	85	GA9050R01		70	JS3201		67					
Model		DCM501 <th colspan="2">53 <th colspan="2">DLS600 <th colspan="2">32 <th colspan="2">DUR365 <th colspan="2">22 <th colspan="2">GA9060 <th colspan="2">71 <th colspan="2">JV0600K <th colspan="2">77</th> </th></th></th></th></th></th></th></th>		53 <th colspan="2">DLS600 <th colspan="2">32 <th colspan="2">DUR365 <th colspan="2">22 <th colspan="2">GA9060 <th colspan="2">71 <th colspan="2">JV0600K <th colspan="2">77</th> </th></th></th></th></th></th></th>		DLS600 <th colspan="2">32 <th colspan="2">DUR365 <th colspan="2">22 <th colspan="2">GA9060 <th colspan="2">71 <th colspan="2">JV0600K <th colspan="2">77</th> </th></th></th></th></th></th>		32 <th colspan="2">DUR365 <th colspan="2">22 <th colspan="2">GA9060 <th colspan="2">71 <th colspan="2">JV0600K <th colspan="2">77</th> </th></th></th></th></th>		DUR365 <th colspan="2">22 <th colspan="2">GA9060 <th colspan="2">71 <th colspan="2">JV0600K <th colspan="2">77</th> </th></th></th></th>		22 <th colspan="2">GA9060 <th colspan="2">71 <th colspan="2">JV0600K <th colspan="2">77</th> </th></th></th>		GA9060 <th colspan="2">71 <th colspan="2">JV0600K <th colspan="2">77</th> </th></th>		71 <th colspan="2">JV0600K <th colspan="2">77</th> </th>		JV0600K <th colspan="2">77</th>		77	
2712	76	DCS551		29	DLS714	new	19	DUR365U		85	GA9060R		71	JV101D		52					
3709	78	DCS553	new	29	DML185		41	DUX60		16	GA9061		71	JV103D		52					
4131	65	DCS7300		89	DML186		41	DUX60		85	GA9061R		71	LB1200F		77					
4327	77	DCS9010		89	DML800		41	DVC260		21	GB602		73	LC1230		66					
6412	59	DCU180		36	DML801		41	DVC862L		20	GB801		73	LD030P		80					
6906	60	DDA460	new	19	DML803		41	DVC863L		20	GD0601		73	LH1200FL		76					
9031	74	DDF083		24	DML805		40	DVC864L		20	GD0603		73	LS1019L		75					
9741	74	DDF453		24	DML806		40	DVF104	new	39	GD0810C		73	LS1040		76					
1911B	78	DDF458		24	DML807		40	DVF104	new	92	GS5000		73	LS1045		76					
2012NB	78	DDF482		24	DML808		40	DVF154	new	39	GS6000		73	LS1219L		75					
2107FK	66	DDF483		24	DP2010		59	DVF154	new	92	GV5010		71	LS1221		75					
4100KB	65	DDF484		24	DP4010		59	DVP180		38	GV7000C	new	71	LW1400		66					
4100NH3	65	DF001D		58	DPC6430		97	DVR850		38	HB500	new	60	LW1401		66					
4112HS	65	DF012D		58	DPC7331		97	DWT310	new	18	HG5030K		79	M0401B		103					
4114S	65	DF031D		49	DPC8132		97	EA3110T25B		88	HG6003		79	M0600B		100					
4350CT	77	DF032D		49	DPT353		38	EA3502S40B		88	HG6030K	new	80	M0801B		100					
5402NA	77	DF331D		49	DRC200		23	EA4301F45B		88	HG6500		80	M0900B		103					
6922NB	61	DF332D		49	DRT50		33	EA6100P45E		88	HK1820		63	M0910B		103					
7104L	new	DF457D		42	DSC102	new	30	EA7300P45E		88	HM0810TA		63	M0920B		104					
9215SB	71	DFJ202D		56	DSC191		29	EA7900P45E		88	HM0870		63	M0921B		104					
9237C	72	DFJ203D		56	DSC250		30	EA7900P60E		88	HM1205		64	M1902B		106					
9553B	67	DFJ210	new	56	DSD180		32	EB5300TH		93	HM1213		63	M2401B		102					
9553NB	67	DFJ211	new	56	DSP600		19	EB7660TH		94	HM1306		64	M3600B		106					
9556HB	67	DFJ212	new	56	DTD152		25	EH5000W		90	HM1812		64	M3601B		106					
9558HN	new	DFJ213	new	56	DTD153		25	EH6000W		90	HP1630		61	M3700B		106					
9565CR	new	DFJ214	new	56	DTD154		25	EH7500W		90	HP2070		61	M4000B		106					
9565CVL	69	DFS250		28	DTD155		25	EK7651H		98	HP331D		49	M4100B		103					
AF353	81	DFS251		28	DTL063		28	EK8100		97	HP332D		49	M4101B		103					
AF505N	81	DFV210	new	56	DTM51		32	ELM3711		86	HP457D		42	M4301B		105					
AF601	81	DGA411	new	31	DTR180	new	34	ELM4110		86	HR140D		50	M4302B		105					
AF635	81	DGA413	new	31	DTW1001		27	ELM4613		86	HR1840		61	M4500KB		106					
AN560	81	DGA417	new	31	DTW1002		27	EM2500U		85	HR2020		61	M5801B		105					
AT1216AZ	80	DGA511	new	31	DTW180	new	27	EM3400U		85	HR2230		61	M6200B		100					
AT638A	81	DGA513	new	31	DTW190		27	EN5950SH		92	HR2470		62	M6202XB		100					
BBA520	95	DGA517	new	31	DTW251		27	EVH2000		92	HR2630		62	M6501B		100					
BHX2500	94	DGA700		15	DTW253		27	EW1050H		95	HR2650		62	M6600B		100					
BO3710	74	DGA701	new	15	DTW285		26	EW1060H		95	HR2651		62	M8600B		101					
BO4556	74	DGA901	new	15	DTW450		27	EY2650H25H		92	HR2810		62	M8700B		101					
BO5031	74	DHP453		25	DUB183		38	FS2700		60	HR3200		62	M8701B		101					
BO6030	74	DHP458		24	DUB183		94	GA4032		67	HR4002		63	M9002B		104					
CC301D	50	DHP482		24	DUB361		22	GA4040		68	HR4003		62	M9100B		104					
CF100D	53	DHP483		25	DUB361		94	GA5010		69	HR4013		62	M9200B		105					
CF101D	new	DHP484		25	DUB362		22	GA5020C		69	HR5202		63	M9201B		105					

Index























M9202B	105	UH5261	91
M9400B	105	UH6570	91
M9506B	103	UK360D <small>new</small>	95
M9508B	104	UM600D	53
M9509B	104	UR100D <small>new</small>	53
M9511B	104	UR100D <small>new</small>	86
M9512B	104	UR3501	85
M9513B	104	VC2510LX1	79
ML103	57	VC3210LX1	79
ML104	57		
ML105	57		
ML106	57		
MLT100	76		
MT410	81		
N5900B	77		
PC5000C	72		
PC5001C	72		
PC5010C <small>new</small>	72		
PJ7000	78		
PLM4620N2	86		
PM7650H	94		
PO5000C	72		
PO6000C	72		
PT354D	52		
PV7000C	72		
PW5001C	72		
RBC411U	85		
RBL500	94		
RP1800	78		
RP2301FC	78		
RT0700C	78		
SA7000C	71		
SD100D	52		
SG1251J	65		
SK104Z	80		
SK105GD <small>new</small>	45		
SK106GD <small>new</small>	45		
SK209GD	45		
SK312GD	45		
SP6000	77		
ST113D	52		
TB131 <small>new</small>	60		
TD0101	60		
TD022D	58		
TD110D	50		
TD111D	50		
TD127D	42		
TL064D	50		
TL065D	50		
TM3000CX1	73		
TM30D	52		
TW0200	60		
TW0350	60		
TW1000	61		
TW100D	58		
TW140D <small>new</small>	50		
UB1102	80		
UC4041A	89		
UH201D	53		
UH201D	92		
UH4261	91		

Icons



	Double Insulation		Hook & Loop
	Variable Speed		SDS-PLUS Shank
	Constant Speed		SDS-PLUS Shank
	Reversing		SDS-MAX Shank
	Mechanical 2-Speed		17mm Hex Shank
	Mechanical 3-Speed		19mm Hex Shank
	Electronic 4-Speed		21mm Hex Shank
	Electronic 3-Speed		28.6mm Hex Shank
	Electronic 2-Speed		Spline Shank
	Brake		30mm Hex Shank
	Torque Setting 5		Bevel Cutting 45 left
	Torque Setting 9		Bevel Cutting L45 R5
	Torque Setting 10		Anti Vibration
	Torque Setting 16		Automatic Oiling
	Torque Setting 18		Chain Brake
	Torque Setting 20		Primer Pump
	Torque Setting 21		Capacitor Discharge Ignition
	Torque Limiter		Decompression Valve
	Dust Collecting		Auto Decompression
	Bayonet Shank Jig Saw Blade		Rapid Start
	Makita Shank Jig Saw Blade		Wooden Carrying Case
	Orbital Cutting		Carrying Case
	Built-in Job Light		
	Keyless Chuck		
	Soft Start		
	Stainless Tank		
	Revolving Hose		
	Static Free Hose		
	Depth Adjusting		
	Sequential or Bump-fire		
	Sequential		
	Wire Collated Nail		
	Sheet Collated Nail		

MAKITA CORDLESS PART NUMBER BREAKDOWN

SF =	Charger (DC18SD), 1 x 18V 3.0Ah Battery (BL1830B)	
RM =	Rapid Charger (DC18RC), 1 x 18V 4.0Ah Battery (BL1840B)	
RT =	Rapid Charger (DC18RC), 1 x 18V 5.0Ah Batteries (BL1850B)	
DWE =	Charger (DC18WA), 2 x 18V 1.5Ah Batteries (BL1815G)	
SYE =	Charger (DC18SD), 2 x 18V 1.5Ah Batteries (BL1815N)	
RFE =	Rapid Charger (DC18RC), 2 x 18V 3.0Ah Batteries (BL1830B)	
RFJ =	Rapid Charger (DC18RC), 2 x 18V 3.0Ah Batteries (BL1830B), Makpac	
RFX1 =	Rapid Charger (DC18RC), 2 x 18V 3.0Ah Batteries (BL1830B), 74 nos Bit Set	
SFE =	Charger (DC18SD), 2 x 18V 3.0Ah Batteries (BL1830B)	
SFE3 =	Charger (DC18SD), 3 x 18V 3.0Ah Batteries (BL1830B)	
SFX1 =	Charger (DC18SD), 2 x 18V 3.0Ah Batteries (BL1830B), Tool Bag	
RME =	Rapid Charger (DC18RC), 2 x 18V 4.0Ah Batteries (BL1840B)	
PT2 =	Rapid Charger Dual Port (DC18RD), 2 x 18V 5.0Ah Batteries (BL1850B)	
RTE =	Rapid Charger (DC18RC), 2 x 18V 5.0Ah Batteries (BL1850B)	
RTJ =	Rapid Charger (DC18RC), 2 x 18V 5.0Ah Batteries (BL1850B), Makpac	
WYE =	Charger (DC10WD), 2 x 12V Max 1.5Ah Batteries (BL1016)	
WYJ =	Charger (DC10WD), 2 x 12V Max 1.5Ah Batteries (BL1016), Makpac	
WAE =	Charger (DC10WD), 2 x 12 Max 2.0Ah Batteries (BL1021B)	
SAE =	Charger (DC10SB), 2 x 12V Max 2.0Ah Batteries (BL1021B)	
DWX =	Charger (DC10WA), 1x10.8V 1.3Ah Battery (BL1013)	
Z =	Tool Only (Batteries, Charger not included)	
ZJ =	Tool Only, Connector Case	

PRODUCTS

▣ CORDLESS TOOLS



Optimum Charging System

22min
for 3.0Ah Battery

Fast Charging with Cooling fan

The charging time in practical condition

In case that the battery that became 70 degrees C right after use is charged in the environment of 25 degrees C.



Total **34min**

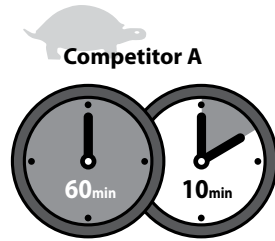

Total **70min**



Cooling fan

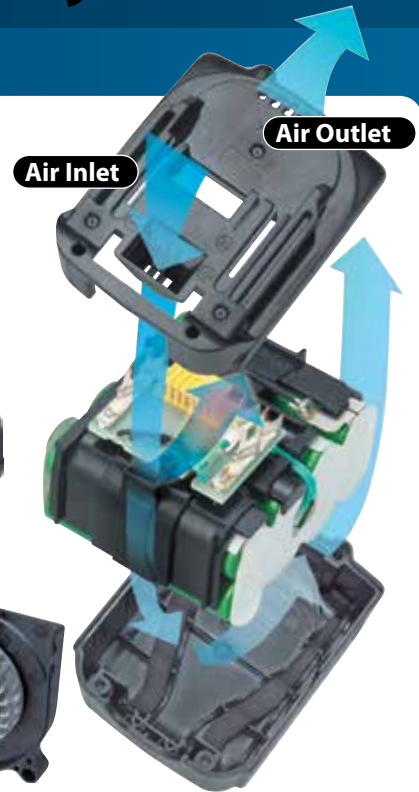

Air Inlet

Air Outlet

It is necessary to cool down the battery before you begin to charge it when you charge the battery, which is the high temperature after use. MAKITA developed the original charger system; Built-in the cooling fan. The stand-by time until the charge starts is greatly shortened by cooling efficiently. In addition, the charger keeps cooling while charging it, and the rapid charge is achieved.

Well Balanced Cooling

The design which air flows efficiently overall and it can cool cell evenly and rapidly. Well-balanced cooling system prevents the load only to a part of cell and makes battery life longer.

MAKITA's Optimum Air flow

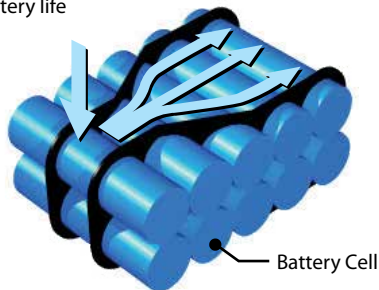

Battery Cell

Competitor A Unbalanced Cooling
Out of air flow

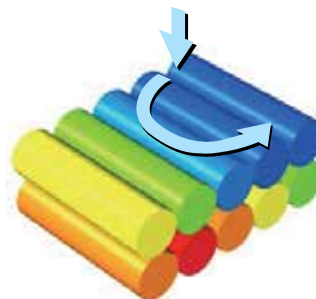

High

Low Temperature



40% Lighter



MAKITA
18V /14.4V
Ni-MH 2.8Ah

MAKITA
18V Li-ion 5.0Ah
14.4V Li-ion 5.0Ah

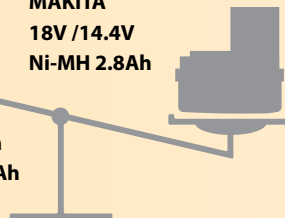

Firm Holding

Multi-contact terminals reduce electrical resistance and increase connection stability withstanding against vibration, and ultimately ensures Stable current supply to the tool.



LXT LITHIUM-ION

430%

Extreme Stamina Life time work volume



The charger communicates with the individual cell in battery and then it controls current, voltage, and temperature. The both rapid and optimum charge was achieved. It made battery life longer.

Total Power Delivery Amount of each battery's service lifetime

Traditional Charging Method

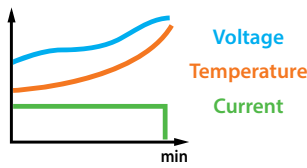

Optimum Charging

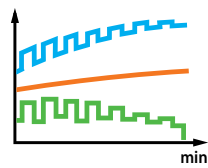

Li-ion 6.0Ah 850

Li-ion 5.0Ah 710

Li-ion 4.0Ah 570

Li-ion 3.0Ah 430

Ni-MH 2.8Ah 130

Ni-Cd 1.9Ah 100

The numbers in the chart are relative values when the amount of Ni-cd 1.9Ah is indexed at 100.

Built-in-CPU

The built-in CPU in battery records the battery usage history and transmits it to the charger.



Digital Communication



Built-in CPU

The CPU built in the charger analyzes its condition; high temperature, re-charge after full charged, over-discharging. The battery lasts long life because it can be charged at the best method and time.



Well Balanced Charging

MAKITA: Capacity Balanced Battery Pack

1. It is designed that an individual cell whose condition is full, discharge, empty works well. It is hard to become the over-discharge and an overcharge because the individual cell capacity prevent to anomalies.
2. It is possible to use it efficiency because the capacity of each cell is not uneven and discharge evenly.

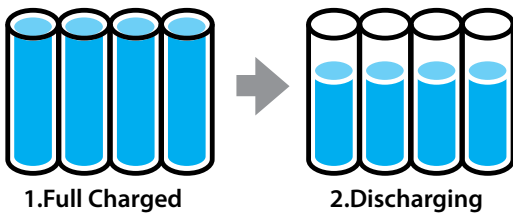

Competitor A : Capacity Unbalanced Battery Pack

1. Competitor charging system causes to decrease the capacity of the cell, which weakened by the heavy load work because Competitors do not install an optimum charge.
2. Discharge stops by using the capacity of the weakened cell completely, when you use the power tool in the condition, noted as above. Therefore the capacities of other cells are not used completely, so that workloads are decreased at a charge.

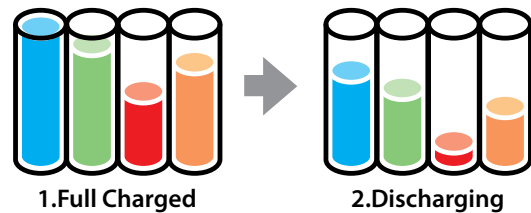

Anytime Charge

No Memory Effect
No discharging required

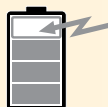

Shock Absorbing

Heavy Duty Pack



Longtime Storage

Low Self Discharge



Batteries and Chargers for Optimum Charging System

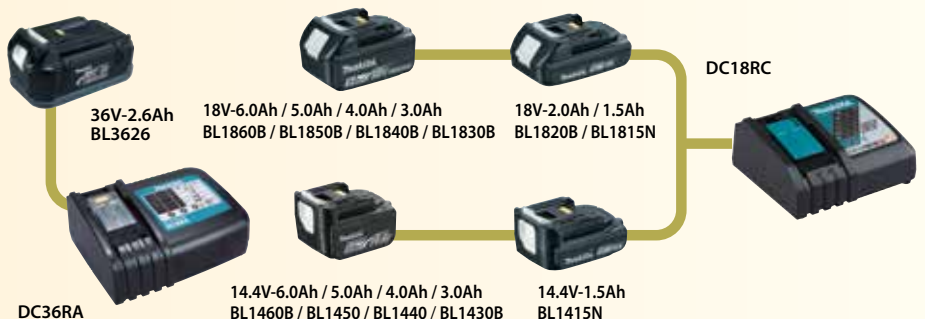

Lighter

Long Life

Smaller

More Work

Stronger

Smarter



High Performance with Brushless DC Motor

Brushless DC motor

- ∴ Maintenance-free due to no brush
- ∴ Energy production is more efficient than brushed DC motor because of no friction loss caused by brushes, enabling to lower amperage for reduced heat production and increased work amount on a single full battery charge.

More work amount on a single full battery charge

- ∴ Thanks to the very efficient energy production of BLDC motor, work amount on a single full battery charge is increased.
- ∴ Life time work amount of a battery is increased, reducing the battery cost.

Durable against continuous long operation

- ∴ Use of BLDC motor lowers heat production; the temperature rise at housing surface can be recessed well even in hard industrial applications requiring continuous long operation.



Li-ion Battery & Charging Time Reference, Compatibility Chart

18V Lithium-ion		DC18RC	DC18RD Two Port Multi Fast Charger	DC18SD
5.0 Ah	BL1850B	45 min.		110 min.
4.0 Ah	BL1840B	36 min.		90 min.
3.0 Ah	BL1830B	22 min.		60 min.
1.5 Ah	BL1815N	15 min.		30 min.

12Vmax Lithium-ion		DC10SB	DC10WD	10.8V Lithium-ion	DC10WA
4.0 Ah	BL1041B	60 min.	130 min.	1.3 Ah	BL1013
2.0 Ah	BL1021B	30 min.	70 min.	7.2V Lithium-ion	DC10WA
1.5 Ah	BL1016	22 min.	50 min.	1.5 Ah	BL0715

18V Lithium-ion		DC18WA
1.5 Ah	BL1815G For Model: DF347D, HP347D, JV143D, ML187, TD126D, UH420D, UH480D, UH520D, UM165D, UR140D, DMR106	70 min.

18V LITHIUM-ION



Recipro Saw

Combination Hammer

Slide Compound Miter Saw

Rotary Hammer

Stapler

Concrete Vibrator

Pin Nailer

Finish Nailer

Brad Nailer

Shear Wrench

Rechargeable Flashlight

Caulking Gun

Corded and LED Worklight

Vacuum Pump

LED Flashlight

Wheelbarrow

Flashlight Radio

Fan

Fan Jacket

Heated Jacket

Heated Vest

Coffee Maker

Job Site Radio

Job Site Speaker

Chain Saw

Grass Shear



18V Lithium-ion

Blower

Hedge Trimmer

Garden Sprayer

Vacuum Cleaner

Trimmer

Grass Trimmer

Cleaner

Robotic Cleaner

Planer

Drywall Saw

String Trimmer

Cyclone Cleaner

Cut-Out Tool

Jig Saw

Plate Joiner



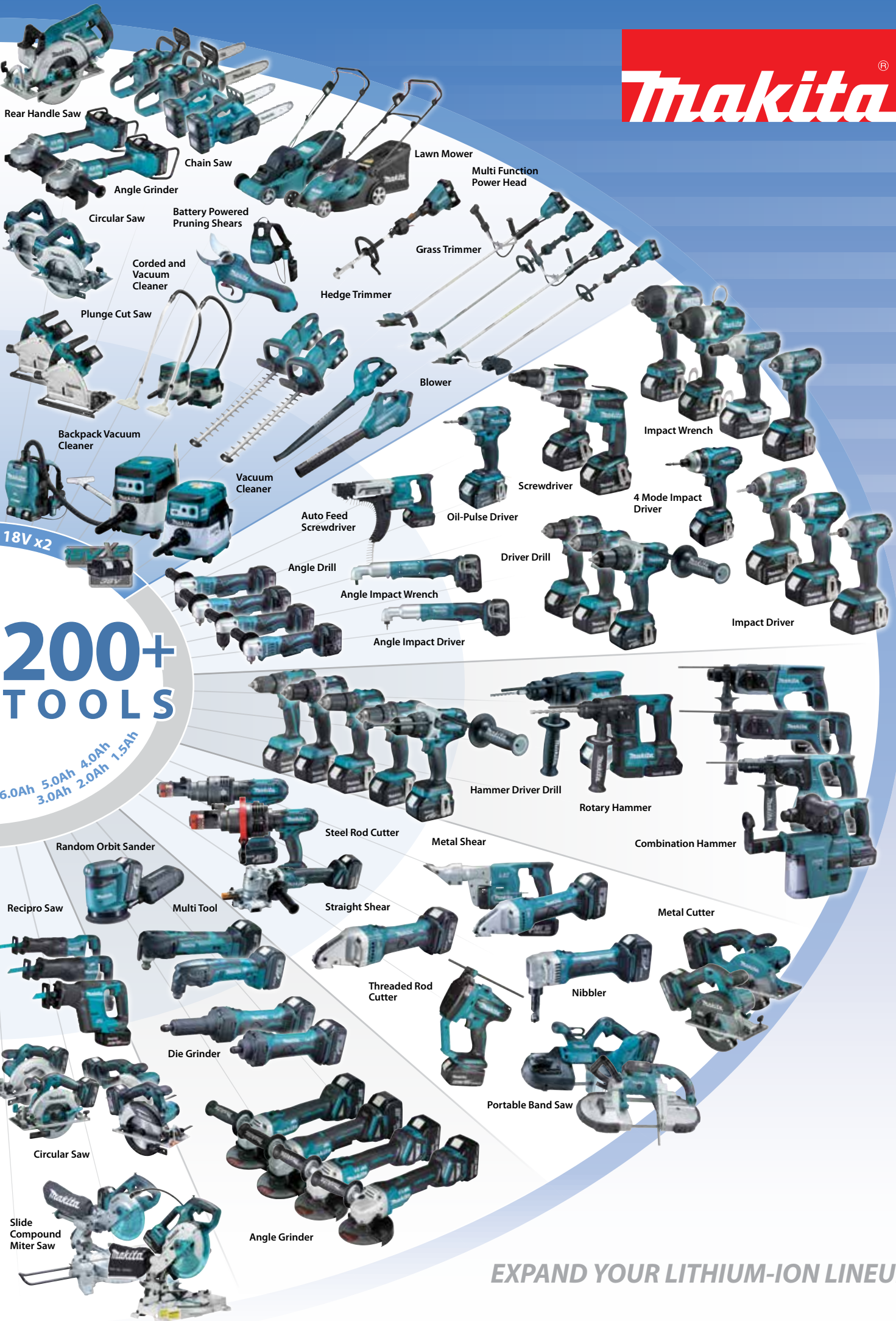

Rear Handle Saw

Chain Saw

Lawn Mower

Multi Function Power Head

Angle Grinder

Circular Saw

Battery Powered Pruning Shears

Grass Trimmer

Corded and Vacuum Cleaner

Hedge Trimmer

Plunge Cut Saw

Blower

Backpack Vacuum Cleaner

Vacuum Cleaner

Auto Feed Screwdriver

Oil-Pulse Driver

Impact Wrench

4 Mode Impact Driver

18V x2

Angle Drill

Driver Drill

Impact Driver

200+ TOOLS

Angle Impact Wrench

Angle Impact Driver

6.0Ah 5.0Ah 4.0Ah 3.0Ah 2.0Ah 1.5Ah

Hammer Driver Drill

Rotary Hammer

Random Orbit Sander

Steel Rod Cutter

Metal Shear

Combination Hammer

Recipro Saw

Multi Tool

Straight Shear

Metal Cutter

Die Grinder

Threaded Rod Cutter

Nibbler

Portable Band Saw

Circular Saw

Angle Grinder

Slide Compound Miter Saw

EXPAND YOUR LITHIUM-ION LINEUP



EXPAND YOUR LITHIUM-ION LINEUP

EXPAND YOUR LITHIUM-ION LINEUP

- Lawn Mower**
DLM431 / DLM380
- Chain Saw**
DUC400 / DUC353 / DUC303 / DUC302 / DUC252 / DUC252C
- Hedge Trimmer**
DUH551 / DUH651
- Grass Trimmer**
DUR366L / DUR365U / DUR364L / DUR362L / DUR361U
- Multi Function Power Head**
DUX60
- Battery Powered Pruning Shears**
DUP361
- Vacuum Cleaner**
DVC862L / DVC863L
- Backpack Vacuum Cleaner**
DVC260
- Corded and Cordless Vacuum Cleaner**
DVC860L / DVC861L
- Shear Wrench**
DWT310
- Rear Handle Saw**
DRS780
- Plunge Cut Saw**
DSP600 / DSP601
- Slide Compound Miter Saw**
DLS714 / DLS110 / DLS111 / DLS112
- Circular Saw**
DHS710 / DHS711
- Recipro Saw**
DJR360
- Angle Grinder**
DGA700 / DGA900
- Rotary Hammer**
DHR400
- Combination Hammer**
DHR263 / DHR264 / DHR280 / DHR281 / DHR282 / DHR283
- Blower**
DUB361 / DUB362

Battery adapter
BAP182

Cordless Angle Grinder

DGA901 *AWS* / DGA900 230mm (9")

DGA701 *AWS* / DGA700 180mm (7")

18v + 18v → 36v



Angle cutting
(DGA701, DGA700)

17 cuts

- Angle steel : 50x50mm
- Battery : BL1850B x2

Single-pass cutting even 50mm angle steel

(with DGA901, DGA900)

High performance and efficiency for heavy-duty grinding/cutting applications



Concrete cutting

6 m

- Cutting depth : 20mm
- Battery : BL1850B x2



BL MOTOR

Faster Cutting with High power and High torque brushless motor

Better gravity balance

High maneuverability in any angle since it is possible to grab the center of gravity



ADT

Automatic torque Drive Technology

automatically changes the cutting speed according to load conditions for an optimum operation:

- On light duty: high-speed rotation mode
- On heavy duty: high torque mode

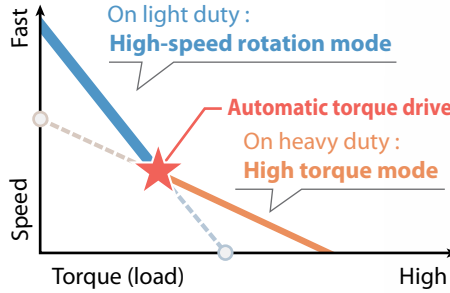

Photo : DGA701



Electric brake

Electric brake is activated after the tool is switched off.

Large switch lever

with lock-off function (without lock-on function) Lock-off function prevents the switch lever from being accidentally pulled.

Anti-restart function

Even if battery is inserted, the motor does not start up when the switch is slide to "on".

AFT

Active Feedback sensing Technology

Shuts down the tool to protect the user, if the rotation speed suddenly slows down.

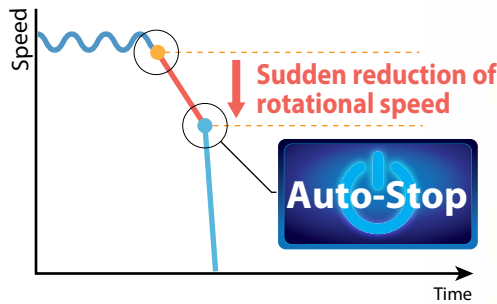

XPT
EXTREME PROTECTION TECHNOLOGY

Soft start

minimizes start-up shock, and makes the tool start smoothly.

Ergonomically designed handle with soft grip

Battery guard



Anti-vibration rubber provides less vibration, allowing comfortable operation.

Battery indicator

- Overheat protection
- Over-discharge protection



Photo: DGA901

AWS Auto-start Wireless System (DGA901, DGA701 only)

The wireless activation function enables clean and comfortable operation. By connecting a supported tool to the cleaner, you can run the cleaner automatically along with the switch operation of the tool.

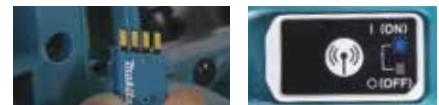

Wireless unit is compatible with all supported tools

Bluetooth® AWS connects to power tool with Bluetooth

The Bluetooth® word mark and logos are registered trademarks owned by the Bluetooth SIG, Inc. and any use of such marks by Makita is under license. Other trademarks and trade names are those of their respective owners.

18v + 18v → 36v

Makita

DGA901

Cordless Angle Grinder

Li-ion Ah 5.0 4.0 3.0 2.0 1.5

new



Wheel Diameter	230 mm (9")
No Load Speed (RPM)	6,000
Surface Grinding with Anti-Vibration Side Grip:	7.5m/s ²
Disc Sanding with Anti-Vibration Side Grip:	2.5m/s ² or less
Sound Pressure Level	88dB(A)
Sound Power Level	99 dB(A)
Dimensions (L x W x H)	499x250x158 mm (19-5/8"x9-7/8"x6-1/4")
Net weight	5.2 - 8.0 kg (11.4 - 17.7 lbs)



Toolless Wheel Cover / Wheel Cover, Side Grip, Lock Nut Wrench

DGA901PT2 - Rs. 68,000

DGA901Z - Rs. 15,000



BL MOTOR

ADT AFT

AWS

XPT



DGA701

Cordless Angle Grinder

Li-ion Ah 5.0 4.0 3.0 2.0 1.5

new



Wheel Diameter	180 mm (7")
No Load Speed (RPM)	7,800
Surface Grinding with Anti-Vibration Side Grip:	7.5m/s ²
Disc Sanding with Anti-Vibration Side Grip:	2.5m/s ² or less
Sound Pressure Level	88dB(A)
Sound Power Level	99 dB(A)
Dimensions (L x W x H)	499x200x158 mm (19-5/8"x7-7/8"x6-1/4")
Net weight	5.0 - 6.0 kg (11.02 - 13.23 lbs.)



Toolless Wheel Cover / Wheel Cover, Side Grip, Lock Nut Wrench

DGA701PT2 - Rs. 68,000

DGA701Z - Rs. 35,000



BL MOTOR

ADT AFT

AWS

XPT



DGA700

Cordless Angle Grinder

Li-ion Ah 5.0 4.0 3.0 2.0 1.5



Wheel Diameter	180 mm (7")
No Load Speed (RPM)	7,800
Surface Grinding with Anti-Vibration Side Grip:	7.5m/s ²
Disc Sanding with Anti-Vibration Side Grip:	2.5m/s ² or less
Sound Pressure Level	88dB(A)
Sound Power Level	99 dB(A)
Dimensions (L x W x H)	499x200x158 mm (19-5/8"x7-7/8"x6-1/4")
Net weight	5.0 - 6.0 kg (11.02 - 13.23 lbs.)



Toolless Wheel Cover / Wheel Cover, Side Grip, Lock Nut Wrench

DGA700PT2 - Rs. 52,000

DGA700Z - Rs. 25,000



BL MOTOR

ADT AFT

XPT





Cordless Multi Function Power Head

DUX60



Multi-function system

consisting of power head and versatile optional attachments are ideal for a wide range of applications



Shaft extension attachment
LE400MP
Length: 1,080mm (42-1/2")
For Pole saw, Pole hedge trimmer and Coffee harvester



High operating efficiency

BL Motor provides high operating efficiency



Active Feedback sensing Technology

Shuts down the tool to protect the user, if the rotation speed suddenly slows down.



Reverse switch for easy removal of grass clippings from the cutting tool

Grass clippings can be removed by slow reverse rotation of the cutting tool (automatically stops in 3 seconds) by pressing Touch button switch and pulling Trigger switch.



Li-ion Ah 5.0 4.0 3.0 2.0 1.5

DUX60

DUX60ZM3



Cordless Multi Function Power Head

No Load Speed (RPM)	High: 0 - 9,700 Medium: 0 - 8,200 Low: 0 - 5,700
Dimensions (L x W x H)	1,011x320x216 mm (39-3/4"x12-5/8"x8-1/2")
Net weight	4.1 - 8.7 kg (8.9 - 19.2 lbs)

18V



DUX60ZM3 - Rs. 40,000
DUX60Z - Rs. 28,000



Extreme Protection Technology



Harness, Safety Goggles, Hex Wrench, Accessory Bag, Tool bag (for spec with Brushcutter attachment only), Carbide-Tipped Saw Blade (for spec with EM402MP only), Box Wrench (for spec with EM402MP / EM403MP / EM404MP only), Metal blade fixing tool (Clamp washer, Nut, Cup) (for spec with EM402MP/EM403MP/EM404MP), Nylon Cutting Head (for spec with EM403MP / EM404MP / EM405MP / EM406MP only)



18v + 18v → 36v

Cordless Chain Saw

DUC353 350 mm (14")

High performance

- High torque thanks to outer rotor Brushless Motor
- High power
- High work efficiency



High operating efficiency

Outer Rotor BL Motor provides high operating efficiency



Extreme Protection Technology

For use in outdoor applications or harsh environments, protection from dust and dripping water is enhanced.



Tool-less saw chain tension adjustment

Extendable lever provides higher tightening torque.
Dial for easier adjustment of saw chain tension



Adjusting the chain oil lubrication

You can adjust the oil pump feed rate with the adjusting screw.

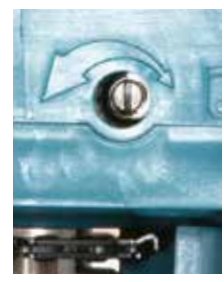

Metal spike bar

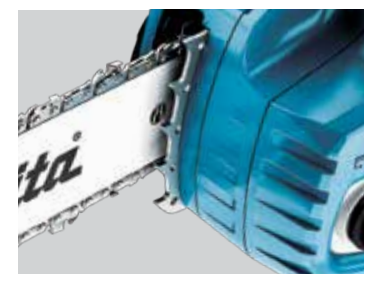

Chain oil level window

allows to check how much oil is left from outside.



Constant speed control

- minimizes reduction in rotation speed under load, keeping operation efficiency.
- Lowers noise under no load.

Metal chain catcher



DUC353 Cordless Chain Saw **Li-ion** Ah 6.0 5.0 4.0 3.0 2.0 1.5



	DUC353	DUC353Z - Rs. 36,000
Guide Bar Length	350 mm (14")	
Chain Pitch	3/8"	
Chain Gauge	1.1 / 1.3 mm (0.043" / 0.050")	
Chain Speed	0 - 20 m/s (0 - 1,200 m/min) (0 - 3,940 FPM)	
Chain Oil Tank Volume	200 mL	
Sound Pressure Level	87.7 dB(A)	
Sound Power Level	100.4 dB(A)	
Vibration Level	Cutting Wood: 5.3 m/s ²	
Dimensions (L x W x H)	773x215x235 mm (30-1/2"x8-1/2"x9-1/4")	
Net weight	4.6 - 5.5 kg (10.2 - 12.1 lbs)	



Saw Chain, Guide Bar, Guide Bar Cover, Oil supply (country-specific)

DWT310 - Cordless Shear Wrench

M16 (5/8"), M20 (3/4"), M22 (7/8")

18v + 18v → 36v

High-speed fastening beyond AC tool

Work efficiency

DWT310 **114%**

Predecessor AC model 100

Test conditions

- Fastening bolt: M22 torque shear bolt
- Battery : BL1850B x2
- AC tool: 50m Cord reel



High power and High torque brushless motor

Fatigue-reducing items



Shoulder belt (for carrying)



Transport hook

Shoulder belt & hook: Don't use them as fall prevention devices



LED warning lamp for battery capacity



- Blinking: Battery power has been almost used up. (when the number of bolts you can tighten is less than about 10.)
- Solid: Battery power has been completely used up.



Accessories

Sleeve size reference table

*Type F (for HEXA TECH (GFD France)) ** for Chinese market

Bolt Size	Outer sleeve		Inner sleeve		Bolt Size	Outer sleeve		Inner sleeve	
	L (mm)	Part No.	L (mm)	Part No.		L (mm)	Part No.	L (mm)	Part No.
M16	35	193804-8	36	195245-4	M22, 7/8"	39	193960-4	39	195218-7
			36	*764421-7				39	*764423-3
M16	81	193807-2	82	193810-3	M22, 7/8"	85	764364-3	85	764352-0
M16	100	764406-3	100	764400-5	M22, 7/8"	100	764410-2	100	764404-7
M16	200	764407-1	200	764401-3	M22, 7/8"	170	764365-1	170	764354-6
M20	37	193805-6	38	195217-9	M22, 7/8"	200	764411-0	200	764405-5
M20	37	**196276-6	38	195217-9	5/8"	35	764362-7	36	764420-9
M20	37	193805-6	38	*764422-5	3/4"	37	764361-9	38	764419-4
M20	83	193806-4	84	193809-8	3/4"	83	764363-5	84	764353-8
M20	100	764408-9	100	764402-1	3/4"	168	764366-9	169	764355-4
M20	200	764409-7	200	764403-9					

DTW310ZK - Rs. 2,20,000

Cordless Shear Wrench

DWT310 M16 (5/8"), M20 (3/4"), M22 (7/8")

Brake	Capacity	Bolt : M16, M20, M22 (5/8"; 3/4"; 7/8")
Carrying Case	No Load Speed (RPM)	14
	Max Fastening Torque	804 N·m (593 ft.lbs.)
	Vibration Level	2.5 m/s ² or less
	Sound Pressure Level	83 dB(A)
	Sound Power Level	94 dB(A)
Standard Equipment :	Dimensions (L x W x H)	296x130x377 mm (11-5/8"x5-1/8"x14-7/8")
- Screwdriver, Battery, Charger	Net weight	6.5 - 7.1 kg (14.3 - 15.7 lbs.)

The weight may differ depending on the attachment(s), including the battery cartridge. The lightest and heaviest combination, according to EPTA-Procedure 01/2014, are shown in the table. Items of standard equipment and specifications may vary by country or area.



18v + 18v → 36v

DHR282 - Cordless Combination Hammer

18V X2 (36V) LXT BL AVT Cordless 28 mm (1-1/8") Combination Hammer, SDS-PLUS Bits **DHR282PT2J - Rs. 75,000**
DHR282Z - Rs. 40,000



new



Li-ion	Ah	6.0	5.0	4.0	3.0	2.0	1.5
Impact Energy		EPTA-Procedure 05/2009: 2.8 J					
Capacity		Concrete / Steel / Wood: 28 / 13 / 32 mm (1-1/8" / 1/2" / 1-1/4")					
Blows Per Minute (BPM)		0 - 5,000					
No Load Speed (RPM)		0 - 980					
Dimensions (L x W x H)		373x134x232 mm (14-3/4"x5-1/4"x9-1/8")					
Net weight		3.9 - 5.0 kg (8.6 - 11.0 lbs)					

XPT BL AVT SOFT NOLOAD
AFT AWS

Side Grip, Depth Gauge, Battery, Charger, Wireless Unit (country-specific), Dust Cup (country-specific), Cleaning cloth (country-specific), Bit Grease (country-specific)

DHR280 - Cordless Combination Hammer

18V X2 (36V) LXT BL AVT SOFT NO LOAD Cordless 28 mm (1-1/8") Combination Hammer, SDS-PLUS Bits **DHR280PT2J - Rs. 68,000**
DHR280Z - Rs. 32,000



new



Li-ion	Ah	6.0	5.0	4.0	3.0	2.0	1.5
Impact Energy		EPTA-Procedure 05/2009: 2.8 J					
Capacity		Concrete / Steel / Wood: 28 / 13 / 32 mm (1-1/8" / 1/2" / 1-1/4")					
Blows Per Minute (BPM)		0 - 5,000					
No Load Speed (RPM)		0 - 980					
Dimensions (L x W x H)		373x134x232 mm (14-3/4"x5-1/4"x9-1/8")					
Net weight		3.9 - 5.0 kg (8.6 - 11.0 lbs)					

XPT BL AVT SOFT NOLOAD

Side Grip, Depth Gauge, Battery, Charger, Dust Cup (country-specific), Cleaning cloth (country-specific), Bit Grease (country-specific)

DLS111 - Cordless Slide Compound Miter Saw

18V X2 (36V) LXT BL AWS ADT DXT Cordless 260 mm (10-1/4") Slide Compound Miter Saw, Laser **DLS111PT2 - Rs. 1,20,000**
DLS111Z - Rs. 87,000



Li-ion	Ah	4.0	2.0	1.5
Blade Diameter		260 mm (10-1/4")		
Miter Angle		60° L / 60° R		
Bevel Angle		48° L / 48° R		
Max Cutting Capacity		90° Miter: 91 x 279 mm (3-5/8" x 11") 90° Miter: 68 x 310 mm (2-11/16" x 12-1/4") 45° Miter, L/R: 91 x 197 mm (3-5/8" x 7-3/4") 45° Miter, L/R: 68 x 218 mm (2-11/16" x 8-5/8")		
No Load Speed (RPM)		4,400		
Sound Pressure Level		92 dB(A)		
Sound Power Level		102 dB(A)		
Noise K factor		3 dB(A)		
Vibration Level		2.5 m/s ² or less		
Vibration K Factor		1.5 m/s ²		
Dimensions (L x W x H)		805x644x660 mm		
Net weight		26.6 - 27.3 kg (58.6 - 60.2 lbs)		

TCT Saw Blade, Dust Bag, Triangular Rule, Vertical Vise, Hex Wrench

DLS714 - Cordless Slide Compound Miter Saw

18V X2 (36V) LXT BL ADT Cordless 190 mm (7-1/2") Dual Slide Compound Miter Saw **DLS714Z - Rs. 80,000**

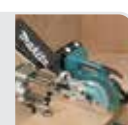

new



Li-ion	Ah	6.0	5.0	4.0	3.0	2.0	1.5
Blade Diameter		190 mm (7-1/2")					
Miter Angle		47° L / 57° R					
Bevel Angle		45° L / 5° R					
Max Cutting Capacity		90°: 52 x 300 mm (2-1/16" x 11-3/4") at 45° left: 40x300 mm (1-9/16" x 11-3/4") at 5° right: 40x300 mm (1-9/16" x 11-3/4")					
No Load Speed (RPM)		5,700					
Sound Pressure Level		88 dB(A)					
Sound Power Level		97 dB(A)					
Vibration Level		2.5 m/s ² or less					
Dimensions (L x W x H)		655x430x445 mm (25-3/4"x17"x17-1/2")					
Net weight		12.6 kg (27.8 lbs)					

TCT Saw Blade, Dust Bag, Holder Set, Vertical Vise, Hex Wrench, Triangular Rule

DHS780 - Cordless Circular Saw

18V X2 (36V) LXT BL ADT Cordless 190/185mm (7-1/2" / 7-1/4") Magnesium Circular Saw, Electric Brake, Soft Start, Dual LED Light **DHS780PT2J - Rs. 68,000**
DHS780Z - Rs. 32,000



Li-ion	Ah	6.0	5.0	4.0	3.0	2.0	1.5
Blade Diameter		190 / 185 mm (7-1/2" / 7-1/4")					
Hole Diameter		15.88 / 20 / 30 mm (5/8" / 13/16" / 1-3/16")					
Max Cutting Capacity		90°: 68.5 / 66 mm (2-11/16" / 2-5/8") 45°: 47.5 / 45.5 mm (1-7/8" / 1-13/16") 56°: 35.5 / 34 mm (1-3/8" / 1-5/16")					
No Load Speed (RPM)		6,000					
Sound Pressure Level		93 dB(A)					
Sound Power Level		104 dB(A)					
Dimensions (L x W x H)		342x200x290 mm (13-1/2"x7-7/8"x11-3/8")					
Net weight		4.2 - 4.8 kg (9.3 - 10.7 lbs)					

TCT Saw Blade, Dust Nozzle, Hex Wrench

DSP600 - Cordless Plunge Cut Saw

18V X2 (36V) LXT BL Cordless 165 mm (6-1/2") Plunge Cut Saw **DSP600Z - Rs. 35,000**



Li-ion	Ah	4.0	2.0	1.5
Blade Diameter		165 mm (6-1/2")		
Bevel Capacity		-1° - 48°		
Max Cutting Capacity		90°: 56 mm (2-3/16") 45°: 40 mm (1-9/16") 48°: 38 mm (1-1/2")		
No Load Speed (RPM)		2,500 - 6,300		
Sound Pressure Level		92 dB(A)		
Sound Power Level		103 dB(A)		
Vibration Level		Cutting Wood: 2.5 m/s ² or less		
Dimensions (L x W x H)		346x241x272 mm (13-5/8"x9-1/2"x10-3/4")		
Net weight		4.4 - 5.1 kg (9.8 - 11.2 lbs)		

TCT Saw Blade, Hex Wrench

DJR360 - Cordless Recipro Saw

18V X2 (36V) LXT BL Brushless Cordless Recipro Saw **DJR360Z - Rs. 30,000**



Li-ion	Ah	6.0	5.0	4.0	3.0	2.0	1.5
Length of Stroke		32 mm (1-1/4")					
Strokes Per Minute (SPM)		High / Low: 0 - 3,000 / 0 - 2,300					
Capacity		Pipe: 130 mm (5-1/8") Wood: 255 mm (10")					
Vibration Level		Cutting Boards: 16.5 m/s ² Cutting Wooden Beams: 15.5 m/s ²					
Sound Pressure Level		85 dB(A)					
Sound Power Level		96 dB(A)					
Dimensions (L x W x H)		449x116x243 mm (17-3/4"x4-9/16"x9-9/16")					
Net weight		4.0 - 4.7 kg (8.9 - 10.3 lbs)					

Recipro Saw Blades

DDA460 - Cordless Angle Drill

18V X2 LXT BL ADT Cordless 13 mm (1/2") Angle Drill with Keyed Chuck **DDA460PT2 - Rs. 90,000**
DDA460ZK - Rs. 36,000



Li-ion	Ah	5.0	4.0	3.0	2.0	1.5	
Capacity		Steel: 13 mm (1/2") Wood (Self-Feed Bit) Hi: 65 mm (2-9/16") Wood (Self-Feed Bit) Lo: 118 mm (4-5/8") Wood (Hole Saw) Hi: 105 mm (4-1/8") Wood (Hole Saw) Lo: 159 mm (6-1/4") Wood (Auger-Bit): 50 mm (2")					
No Load Speed (RPM)		High / Low: 0 - 1,400 / 0 - 350					
Max Output		1,350 W					
Dimensions (L x W x H)		538x128x223 mm (21-1/4"x5"x8-3/4") w/ Front Handle Extended: 608x128x193 mm (24"x5"x7-5/8")					
Net weight		5.7 - 6.4 kg (12.6 - 14.0 lbs)					

Chuck Key, Hex Wrench, Side Grip



Cordless Vacuum Cleaner

DVC864L (only Dry / HEPA filter / AWS)
DVC862L (Wet & Dry) / DVC863L (only Dry / HEPA filter)

- Auto-Start Wireless System (AWS) Connects to Power Tool with Bluetooth(DVC864L)
- Two 18V LXT Li-Ion batteries & BL motor deliver the power and performance
- HEPA Filter is used to capture very fine particles effectively



▲ DVC864L only



Max air flow	Max sealed suction
2.1 m³/ min	9.8kPa

(with two batteries BL1850B, suction power mode: 5, hose 38-25)



DVC864L

DVC862L / DVC863L



DVC864L



Continuous run time
40min
 (with BL1850B)

DVC864L - Cordless Vacuum Cleaner

18V X2 (36V) LXT BL AWS Cordless 8 L Dust Class L HEPA Vacuum Cleaner

DVC864LZ - Rs. 53,000
DVC864LZX - Rs. 47,000



Li-ion	Ah	4.0	2.0	1.5
Capacity	Dust / Water: 8 L			
Continuous Use (min.)	w/ BL1850B x2: 40			
Max Air Flow	2.1 m ³ /min			
Max Sealed Suction	9.8 kPa			
Vibration Level	2.5 m/s ² or less			
Sound Pressure Level	70 dB(A) or less			
Dimensions (L x W x H)	366x334x368 mm			
Net weight	7.7 kg (17.1 lbs.)			



Hose complete front cuff (22.24.38), Plastic Dust Bag x10, Cloth Filter, Tool Box

DVC862L - Cordless Vacuum Cleaner

18V X2 (36V) LXT BL Brushless Cordless 8 L Dust Class L Vacuum Cleaner (Wet & Dry)

DVC862LRT2 - Rs. 68,000



Li-ion	Ah	4.0	2.0	1.5
Capacity	Dust / Water: 8 / 6 L			
Continuous Use (min.)	w/ BL1850B x2: 40			
Max Air Flow	2.1 m ³ /min			
Max Sealed Suction	9.8 kPa			
Suction Power	90 W			
Vibration Level	2.5 m/s ² or less			
Sound Pressure Level	70 dB(A) or less			
Dimensions (L x W x H)	366x334x368 mm			
Net weight	7.0 - 7.6 kg (15.5 - 16.8 lbs)			



Floor Nozzle, Corner Nozzle, Straight Pipe, Bent Pipe, Hose (38mm-2.5m), Plastic Dust Bag, Plastic Dust Bag x10, Cloth Filter, Tool Box



DVC863L - Cordless Vacuum Cleaner

18V X2 (36V) LXT BL Brushless Cordless 8 L Dust Class L HEPA Vacuum Cleaner

DVC863LZX - Rs. 42,000



Li-ion	Ah	4.0	2.0	1.5
Capacity	Dust / Water: 8 / 6 L			
Continuous Use (min.)	w/ BL1850B x2: 40			
Max Air Flow	2.1 m ³ /min			
Max Sealed Suction	9.8 kPa			
Suction Power	90 W			
Vibration Level	2.5 m/s ² or less			
Sound Pressure Level	70 dB(A) or less			
Dimensions (L x W x H)	366x334x368 mm			
Net weight	7.7 - 8.4 kg (17.1 - 18.4 lbs)			



Hose complete front cuff (22.24.38), Plastic Dust Bag x10, Cloth Filter, Tool Box

18v + 18v → 36v

DVC260



Long run time
90min
(with BL1850B)

Light and Comfortable
3.8kg
(with BL1820B)

HEPA filter



Able to capture 99.97% of particles as small as 0.3-1µm

Comfortable harness



featuring shoulder and waist belts adjustable to suit user's size for less fatigue even after long continuous operation

Controller



- OFF switch
- High/ Low power selection
- ON-OFF switch for LED job light

Cordless Backpack Vacuum Cleaner

For tool connection use

Li-Ion Ah 6.0 5.0 4.0 3.0 2.0 1.5



DVC260	
Capacity	Filter bag / Paper dust bag: 2.0 / 2.0L Cloth dust bag: 1.5 L
Continuous Use (min.)	with BL1850B (High): 60 with BL1850B (Low): 90
Max Air Flow	1.5 m ³ /min
Max Sealed Suction	7.1 kPa (710 mmHg ₀)
Vibration Level	Operation without Load: 2.5 m/s ² or less
Sound Pressure Level	70 dB(A) or less
Dimensions (L x W x H)	230x152x373 mm (9"x6"x14-3/4")
Net weight	3.8 - 4.3 kg (8.5 - 9.6 lbs)

Max air flow
1.5m³/ min

Max sealed suction
7.1kPa



Hose complete front cuff (22.24.38)

DVC260Z - Rs. 28,000
DVC260ZX - Rs. 26,000

HEPA filter

High Efficiency Particulate Air

Apart from the above standard regulated by IEC/EN 60335-2-69, "HEPA" is widely recognized as one of famous guidelines of the filtration efficiency.

According to this standard, the filter of "HEPA" should remove more than 99.75% of airborne particles of 0.3µm in diameter.

Thus, it stipulates only a filtration efficiency of the filter itself, while IEC/EN60335-2-69 defines the vacuum machine suitable for each dust class (construction, mechanical strength of machine) as well as its dust permeability. In this sense, Dust Class H vacuum cleaner does not always have to be equipped with HEPA filter as long as it meets the requirements of IEC/EN60335-2-69.

Another difference between HEPA testing methods and the IEC/EN60335-2-69 is the dust loading. Filter elements for dust classes M and H are to be tested with the limestone dust particles in large quantities for checking the physical strength of filter, while HEPA tests are done with very small liquid droplets.



DUB361 - Cordless Blower

18V X2 (36V) LXT Li-Ion Cordless 2-Speed Blower **DUB361Z - Rs. 19,000**



Li-ion Ah	4.0	2.0	1.5	430	mm
Max Air Volume	High: 4.4 m ³ /min (155 CFM) Low: 2.6 m ³ /min (92 CFM)				
Max Air Velocity	High: 93 m/s (208 MPH) Low: 57 m/s (128 MPH)				
No Load Speed (RPM)	High: 17,000 Low: 10,000				
Sound Pressure Level	82.3 dB(A)				
Sound Power Level	94.7 dB(A)				
Vibration Level	2.5 m/s ² or less				
Dimensions (L x W x H)	905x141x194 mm (35-5/8"x5-5/8"x7-5/8")				
Net weight	3.1 - 3.2 kg (6.8 - 7.1 lbs)				

XPT EXTREME PROTECTION TECHNOLOGY

Shoulder Belt, Nozzle

DUB362 - Cordless Blower

18V X2 (36V) LXT BL Brushless Cordless Variable 6-Speed Blower **DUB362Z - Rs. 28,000**



Li-ion Ah	4.0	2.0	1.5		
Max Air Volume	13.4 m ³ /min (473 CFM)				
Max Air Velocity	54 m/s (120 MPH)				
No Load Speed (RPM)	11,400 - 21,500				
Sound Pressure Level	79.1 dB(A)				
Sound Power Level	93.5 dB(A)				
Vibration Level	2.5 m/s ² or less				
Dimensions (L x W x H)	830/880/930x205x295 mm (32-3/4"/34-3/4"/36-5/8"x8-1/8"-11-5/8")				
Net weight	3.5 - 4.2 kg (7.7 - 9.3 lbs)				

XPT BL MOTOR EXTREME PROTECTION TECHNOLOGY

Shoulder Belt, Nozzle

DUP361 - Cordless Pruning Shear

Battery Powered Pruning Shears powered by two 18V Li-ion batteries in series **DUP361Z - Rs. 1,20,000**



Li-ion Ah	5.0	4.0	3.0	2.0	1.5
Max Output	200 W				
Capacity	Max cutting: 33 mm Max blade opening: 54 mm				
Sound Pressure Level	70 dB(A) or less				
Vibration Level	2.5 m/s ² or less				
Dimensions (L x W x H)	305x43x106 mm (12"x1-11/16"x4-3/16")				
Net weight	0.8 kg (1.8 lbs)				

XPT EXTREME PROTECTION TECHNOLOGY

Oil supply, Wrench set, Diamond file, Cord holder complete, Holster, Harness, Arm band, Tool bag, Shear blade (U)

DUR365 - Cordless Grass Trimmer

18V X2 (36V) LXT BL Brushless Cordless 3-Speed Grass Trimmer, Bike Handle **DUR365URM2 - Rs. 59,000**
DUR365UZ - Rs. 37,000



Li-ion Ah	5.0	4.0	3.0	1.5	
Cutting Width	Metal Blade: 230 mm (9") Trimmer Head: 350 mm (13-3/4") Plastic Blade: 255 mm (10")				
No Load Speed (RPM)	High / Medium / Low: 6,500 / 5,300 / 3,500 M10 x 1.25 LH				
Sound Pressure Level	Metal Blade: 75 dB(A)				
Sound Power Level	Metal Blade: 86 dB(A)				
Sound Pressure Level	Plastic Blade: 83 dB(A)				
Sound Power Level	Plastic Blade: 92.8 dB(A)				
Sound Pressure Level	Nylon Cutting Head: 77 dB(A)				
Sound Power Level	Nylon Cutting Head: 90 dB(A)				
Vibration Level	Left / Right: 2.5 / 2.5 m/s ² or less				
Dimensions (L x W x H)	1,754x610x460 mm (69"x24"x18-1/8") with BL1850B: 490				
Max Run Time (min)	4.3 - 5.0 kg (9.6 - 11.0 lbs)				
Net weight					

BL MOTOR XPT EXTREME PROTECTION TECHNOLOGY

Battery cover, Safety goggles, Accessory bag, Hex wrench 4, Box driver, Blade cover, Shoulder belt

DLM460 - Cordless Lawn Mower

18V X2 (36V) LXT BL Brushless Cordless 46 cm (18-1/8") 3-in-1 Mower **DLM460PTZ - Rs. 98,000**
DLM460Z - Rs. 65,000



Li-ion Ah	5.0	4.0	3.0	1.5
Blade Type	2 Tooth			
Hole Diameter	10.0 mm (3/8")			
Cutting Width	460 mm (18-1/8")			
Cutting Height	20 - 75 mm (13/16" - 2-5/16")			
Grass box capacity	60 L			
No Load Speed (RPM)	2,500 - 3,300			
Recommended mowing area w/ BL1860B x2:	800 - 1,600 m ²			
Actual mowing area on a single full battery charge	w/ BL1860B x2: 800 m ²			
Continuous Use (min.)	w/ BL1860B: 21			
Wheel Size	Front / Rear: 180 / 205 mm (7 / 8")			
Max Output	1,450 W			
Dimensions (L x W x H)	1,319-1,518x532x879-1,138 mm (52"-59-3/4"x21"x34-1/2"-44-3/4")			
Net weight	25.3 - 27.6 kg (55.8 - 60.8 lbs.)			

BL MOTOR

Blade, Socket Wrench



DUH651 - Cordless Hedge Trimmer

18V X2 (36V) LXT Li-Ion Cordless 65cm (25-1/2") Hedge Trimmer **DUH651Z - Rs. 35,000**



Li-ion Ah	5.0	4.0	3.0	2.0	1.5	442	mm
Blade Length	650 mm (25-1/2")						
Strokes Per Minute (SPM)	2,000 - 3,600						
Tooth Spacing	36 mm (1-7/16")						
Sound Pressure Level	82 dB(A)						
Sound Power Level	91.1 dB(A)						
Vibration Level	2.5 m/s ² or less						
Dimensions (L x W x H)	1,135x225x200 mm (44-3/4"x8-7/8"x7-7/8")						
Net weight	4.7 - 5.5 kg (10.3 - 12.0 lbs)						

XPT EXTREME PROTECTION TECHNOLOGY

Blade Cover

DUH551 - Cordless Hedge Trimmer

18V X2 (36V) LXT Li-Ion Cordless 55 cm (21-5/8"), Hedge Trimmer **DUH551Z - Rs. 35,000**



Li-ion Ah	5.0	4.0	3.0	2.0	1.5	442	mm
Blade Length	2,000 - 3,600						
Strokes Per Minute (SPM)	36 mm (1-7/16")						
Tooth Spacing	82 dB(A)						
Sound Pressure Level	91.1 dB(A)						
Sound Power Level	2.5 m/s ² or less						
Vibration Level	1,135x225x200 mm						
Dimensions (L x W x H)	(44-3/4"x8-7/8"x7-7/8")						
Net weight	4.7 - 5.5 kg (10.3 - 12.0 lbs)						

XPT EXTREME PROTECTION TECHNOLOGY

Blade Cover

Makita's Intelligent Robotic Cleaner

provides tomorrow's advanced cleaning today for office buildings, warehouses or stores.



Powered by two 18V Li-ion battery
With BL1850Bx2, able to clean surface area of



Large side brushes + Large power brush

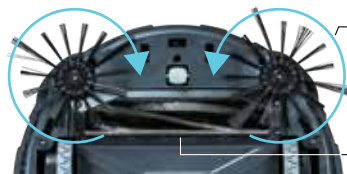

Side brushes enable to clean alongside walls, around obstacles or tight corners in either of pattern/ random.

ø50mm x 260mm Large power rotating brush

About two and a half tennis courts

*about 500m² with BL1850Bx2

Dust box with 2.5L capacity

Dual compartment structure - one for small debris, the other for large debris - is ideal for commercial use.

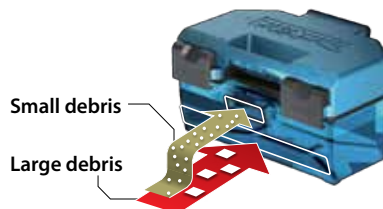

Vacuum fan sucks up small debris into upper compartment.

Power brush picks up large debris into lower compartment.

DRC200Z - Rs. 1,20,000

DRC200

Robotic Cleaner

Li-ion Ah 5.0 4.0 3.0 2.0 1.5

18V LXT BL Brushless Robotic Cleaner

- Makita's Intelligent Robotic Cleaner For Commercial / Industrial Use
- Automatic Cleaning thanks to many sensors with selectable two running modes: Random Mode Cleaning / Pattern Mode Cleaning
- Cleaning Area Setting Function enables user to define a cleaning area.
- Able to clean an area of 300 m² per 120 min with a coverage rate of 80% (two BL1830B in parallel)

18V

Continuous Use (min.)	with BL1850B x2: 200 with BL1830B x2: 120
Max cleaning area	with BL1850B x2: 500 m ² with BL1830B x2: 300 m ²
Max running speed	0.3 m/sec
Dust Box Capacity	2.5 L
Dimensions (L x W x H)	460x460x180 mm (18-1/8"x18-1/8"x7-1/8")
Net weight	7.8 kg (16.1 lbs)

Standard Equipment : Wireless remote controller (including two AAA alkaline batteries), Side Brush, Boundary Tape





DDF458 - Cordless Driver Drill

18V LXT Li-Ion Cordless 13 mm (1/2") 84 N-m (750 in.lbs.) Driver Drill

DDF458RFE - Rs. 40,000



Li-ion	Ah	5.0	4.0	3.0	1.5
Capacity		Steel: 13mm (1/2") Wood: 76mm (3")			
No load speed (rpm)		Hi: 0-2,000 Lo: 0-400			
Max fastening torque		Hard/Soft: 91 / 58N-m			
Max lock torque		84 N-m (750 in.lbs.)			
Dimensions (L x W x H)		225x79x259mm (8-7/8"x3-1/8"x10-1/4")			
Net weight		2.0kg (4.4lbs)			

(+)(-) bit

DDF482 - Cordless Driver Drill

18V LXT Li-Ion Cordless 13 mm (1/2") 54 N-m (480 in.lbs.) Driver Drill

DDF482RFE - Rs. 28,000



Li-ion	Ah	5.0	4.0	3.0	1.5	440
Capacity		Steel / Wood: 13 / 38 mm (1/2" / 1-1/2")				
Chuck capacity		1.5 - 13 mm (1/16 - 1/2")				
No Load Speed (RPM)		High / Low: 0 - 1,900 / 0 - 600				
Max Fastening Torque		Hard / Soft: 62 / 36 N-m (550 / 320 in.lbs.)				
Max lock torque		54 N-m (480 in.lbs.)				
Vibration Level		Drilling Into Metal: 2.5 m/s ² or less				
Sound Pressure Level		75 dB(A)				
Dimensions (L x W x H)		185x79x249 mm (7-1/4"x3-1/8"x9-3/4")				
Net weight		1.5 kg (3.3 lbs)				

(+)(-) bit 2-45, Belt clip, Battery cover

DDF484 - Cordless Driver Drill

18V LXT BL Brushless Cordless 13 mm (1/2") 60 N-m (530 in.lbs.) Driver Drill

DDF484RFE - Rs. 42,000
DDF484Z - Rs. 18,000



Li-ion	Ah	5.0	4.0	3.0	1.5
Capacity		Steel / Wood: 13 / 38 mm (1/2" / 1-1/2")			
Chuck capacity		1.5 - 13 mm (1/16 - 1/2")			
No Load Speed (RPM)		High / Low: 0 - 2,000 / 0 - 500			
Max Fastening Torque		Hard / Soft: 54 / 23 N-m (480 / 210 in.lbs.)			
Max lock torque		60 N-m (530 in.lbs.)			
Vibration Level		Drilling Into Metal: 2.5 m/s ² or less			
Sound Pressure Level		76 dB(A)			
Dimensions (L x W x H)		172x79x261 mm (6-3/4"x3-1/8"x10-1/4")			
Net weight		1.5 - 1.8 kg (3.3 - 4.0 lbs)			

(+)(-) bit

DDF453 - Cordless Driver Drill

18V LXT Li-Ion Cordless 13 mm (1/2") 38 N-m (340 in.lbs.) Driver Drill

DDF453SFE - Rs. 28,000
DDF453SFE3 - Rs. 30,000



Li-ion	Ah	5.0	4.0	3.0	1.5
Capacity		Steel: 13mm (1/2") Wood: 36mm (1-7/16")			
No load speed (rpm)		Hi: 0-1,300 Lo: 0-400			
Max fastening torque		Hard / Soft: 42 / 27N-m 220x79x244mm			
Max lock torque		38 N-m (340 in.lbs.)			
Dimensions (L x W x H)		222x79x244 mm (8-3/4"x3-1/8"x9-5/8")			
Net weight		1.6kg (3.5lbs)			

(+)(-) bit

DDF483 - Cordless Driver Drill

18V LXT BL Brushless Cordless 13 mm (1/2") 40 N-m (350 in.lbs.) Driver Drill

DDF483RFE - Rs. 40,000
DDF483Z - Rs. 16,000



Li-ion	Ah	5.0	4.0	3.0	1.5
Capacity		Steel / Wood: 13 / 36 mm (1/2" / 1-7/16")			
Chuck capacity		1.5 - 13 mm (1/16 - 1/2")			
No Load Speed (RPM)		High / Low: 0 - 1,700 / 0 - 500			
Max Fastening Torque		Hard / Soft: 40 / 23 N-m (350 / 210 in.lbs.)			
Max lock torque		40 N-m (350 in.lbs.)			
Vibration Level		Drilling Into Metal: 2.5 m/s ² or less			
Sound Pressure Level		77 dB(A)			
Dimensions (L x W x H)		162x79x247 mm (6-3/8"x3-1/8"x9-3/4")			
Net weight		1.2 - 1.6 kg (2.7 - 3.4 lbs)			

Belt Clip, (+)(-) bit

DDF083 - Cordless Driver Drill

18V LXT BL Brushless Cordless 6.35 mm (1/4") Hex 40 N-m (350 in.lbs.) Driver Drill

DDF083RFE - Rs. 38,000
DDF083Z - Rs. 14,000



Li-ion	Ah	5.0	4.0	3.0	1.5
Capacity		Steel / Wood: 13 / 36 mm (1/2" / 1-7/16")			
Chuck capacity		6.35 mm (1/4")			
No Load Speed (RPM)		High / Low: 0 - 1,700 / 0 - 500			
Max Fastening Torque		Hard / Soft: 40 / 23 N-m (350 / 210 in.lbs.)			
Max lock torque		40 N-m (350 in.lbs.)			
Vibration Level		Drilling Into Metal: 2.5 m/s ² or less			
Sound Pressure Level		77 dB(A)			
Dimensions (L x W x H)		124x79x247 mm (4-7/8"x3-1/8"x9-3/4")			
Net weight		1.1 - 1.4 kg (2.4 - 3.0 lbs)			

Belt Clip, (+)(-) bit, Phillips bit

DHP458 - Cordless Hammer Driver Drill

18V LXT Li-Ion Cordless 13 mm (1/2") 84 N-m (750 in.lbs.) Hammer Driver Drill

DHP458RFE - Rs. 45,000



Li-ion	Ah	5.0	4.0	3.0	1.5
Capacity		Steel: 13 mm (1/2") Wood: 76 mm (3") Masonry: 16 mm (5/8")			
No Load Speed (RPM)		High: 0-2,000 Low: 0-400			
Impacts Per Minute (IPM)		High: 0-30,000 Low: 0-6,000			
Max Fastening Torque		Hard / Soft: 91 / 58 N-m			
Max lock torque		84 N-m (750 in.lbs.)			
Dimensions (L x W x H)		225x79x259 mm (8-7/8"x3-1/8"x10-1/4")			
Net weight		2.0 kg (4.5 lbs)			

(+) (-) Bit

DHP482 - Cordless Hammer Driver Drill

18V LXT Li-Ion Cordless 13 mm (1/2") 54 N-m (480 in.lbs.) Hammer Driver Drill

DHP482RFE - Rs. 30,000



Li-ion	Ah	5.0	4.0	3.0	1.5
Capacity		Steel / Wood / Masonry: 13 / 38 / 13 mm (1/2" / 1-1/2" / 1/2")			
Chuck capacity		1.5 - 13 mm (1/16 - 1/2")			
Impacts Per Minute (IPM)		High / Low: 0 - 28,500 / 0 - 9,000			
No Load Speed (RPM)		High / Low: 0 - 1,900 / 0 - 600			
Max Fastening Torque		Hard / Soft: 62 / 36 N-m (550 / 320 in.lbs.)			
Max lock torque		54 N-m (480 in.lbs.)			
Vibration Level		Hammer Drilling Into Concrete: 6.0 m/s ²			
Vibration Level		Drilling Into Metal: 2.5 m/s ² or less			
Dimensions (L x W x H)		198x79x249 mm (7-3/4"x3-1/8"x9-3/4")			
Net weight		1.5 kg (3.4 lbs)			

(+)(-) bit 2-45, Belt clip



DHP484 - Cordless Hammer Driver Drill

18V LXT BL Brushless Cordless 13 mm (1/2")
60 N-m (530 in.lbs.) Hammer Driver Drill



Fast Charger, Belt Clip, (+)(-) bit

Li-ion	Ah	5.0	4.0	3.0	1.5
Capacity		Steel / Wood / Masonry: 13 / 38 / 13 mm (1/2" / 1-1/2" / 1/2")			
Chuck capacity		1.5 - 13 mm (1/16 - 1/2")			
Impacts Per Minute (IPM)		High / Low: 0 - 30,000 / 0 - 7,500			
No Load Speed (RPM)		High / Low: 0 - 2,000 / 0 - 500			
Max Fastening Torque		Hard / Soft: 54 / 30 N-m (480 / 270 in.lbs.)			
Max lock torque		60 N-m (530 in.lbs.)			
Vibration Level		Hammer Drilling Into Concrete: 8.0 m/s ²			
Vibration Level		Drilling Into Metal: 2.5 m/s ² or less			
Sound Pressure Level		88 dB(A)			
Sound Power Level		99 dB(A)			
Dimensions (L x W x H)		182x79x261 mm (7-1/8"x3-1/8"x10-1/4")			
Net weight		1.6 - 1.9 kg (3.5 - 4.2 lbs)			

DHP453 - Cordless Hammer Driver Drill

18V LXT Li-Ion Cordless 13 mm (1/2")
38 N-m (340 in.lbs.) Hammer Driver Drill



(+)(-) bit

Li-ion	Ah	5.0	4.0	3.0	1.5
Capacity		Steel: 13 mm (1/2") Wood: 36 mm (1-7/16") Masonry: 13 mm (1/2")			
Impacts Per Minute (IPM)		High: 0-19,500 Low: 0-6,000			
No Load Speed (RPM)		High: 0-1,300 Low: 0-400			
Max Fastening Torque		Hard / Soft: 42 / 27 N-m			
Max lock torque		38 N-m (340 in.lbs.)			
Dimensions (L x W x H)		240x79x244 mm (9-7/16"x3-1/8"x9-5/8")			
Net weight		1.7 - 2.0 kg (3.6 - 4.4 lbs)			

DHP483 - Cordless Hammer Driver Drill

18V LXT BL Brushless Cordless 13 mm (1/2")
40 N-m (350 in.lbs.) Hammer Driver Drill



Belt Clip, (+)(-) bit

Li-ion	Ah	5.0	4.0	3.0	1.5
Capacity		Steel / Wood / Masonry: 13 / 36 / 13 mm (1/2" / 1-7/16" / 1/2")			
Chuck capacity		1.5 - 13 mm (1/16 - 1/2")			
Impacts Per Minute (IPM)		High / Low: 0 - 25,500 / 0 - 7,500			
No Load Speed (RPM)		High / Low: 0 - 1,700 / 0 - 500			
Max Fastening Torque		Hard / Soft: 40 / 23 N-m (350 / 210 in.lbs.)			
Max lock torque		40 N-m (350 in.lbs.)			
Vibration Level		Hammer Drilling Into Concrete: 10.0 m/s ²			
Vibration Level		Drilling Into Metal: 2.5 m/s ² or less			
Sound Pressure Level		83 dB(A)			
Sound Power Level		94 dB(A)			
Dimensions (L x W x H)		176x79x247 mm (6-15/16"x3-1/8"x9-3/4")			
Net weight		1.3 - 1.6 kg (2.8 - 3.6 lbs)			

DTD154 - Cordless Impact Driver

18V LXT BL Brushless 1/4"Hex Cordless
T-Mode 3-Speed 175 N-m (1,550 in.lbs.)
Impact Driver



2 Batteries, Fast Charger, Belt Clip

Li-ion	Ah	5.0	4.0	3.0	1.5
Capacity		Machine Screw: M4 - M8 (5/32" - 5/16") Standard Bolt: M5 - M16 (3/16" - 5/8") High Tensile Bolt: M5 - M14 (3/16" - 9/16") Coarse thread (in length): 22 - 125 mm (7/8" - 4-7/8")			
Hex Shank		6.35 mm (1/4")			
No Load Speed (RPM)		0 - 3,600 / 0 - 2,100 / 0 - 1,100			
Impacts Per Minute (IPM)		0 - 3,800 / 0 - 2,600 / 0 - 1,100			
Max Fastening Torque		175 N-m (1,550 in.lbs.)			
Vibration Level		12.5 m/s ²			
Sound Pressure Level		96 dB(A)			
Sound Power Level		107 dB(A)			
Dimensions (L x W x H)		117x79x236 mm (4-5/8"x3-1/8"x9-1/4")			
Net weight		1.2 kg (2.7 lbs)			

DTD153 - Cordless Impact Driver

18V LXT BL Brushless 1/4"Hex Cordless 170
N-m (1,500 in.lbs.) Impact Driver



Belt Clip

Li-ion	Ah	5.0	4.0	3.0	1.5
Capacity		Machine screw: M4 - M8 (5/32" - 5/16") Standard bolt: M5 - M16 (3/16" - 5/8") High strength bolt: M5 - M14 (3/16" - 9/16") Coarse thread (in length): 22 - 125mm (7/8" - 4-7/8")			
Impacts per minute (ipm)		0 - 3,600			
No load speed (rpm)		0 - 3,400			
Max. fastening torque		170 N-m (1,500 in.lbs.)			
Vibration Level		13.0 m/s ²			
Sound Pressure Level		96 dB(A)			
Sound Power Level		107 dB(A)			
Dimensions (L x W x H)		126x79x238mm (5"x3-1/8"x9-3/8")			
Net weight		1.3 kg (2.8 lbs)			

DTD152 - Cordless Impact Driver

18V LXT Li-Ion 1/4"Hex Cordless 165 N-m
(1,460 in.lbs.) Impact Driver



Belt clip, Battery cover

Li-ion	Ah	5.0	4.0	3.0	1.5	448	mm
Capacity		Machine Screw: M4 - M8 (5/32" - 5/16") Standard Bolt: M5 - M16 (3/16" - 5/8") High Tensile Bolt: M5 - M12 (3/16" - 1/2") Coarse thread (in length): 22 - 125 mm (7/8" - 4-7/8")					
Hex Shank		6.35 mm (1/4")					
No Load Speed (RPM)		0 - 2,900					
Impacts Per Minute (IPM)		0 - 3,500					
Max Fastening Torque		165 N-m (1,460 in.lbs.)					
Vibration Level		10.5 m/s ²					
Sound Pressure Level		93 dB(A)					
Sound Power Level		104 dB(A)					
Dimensions (L x W x H)		137x79x238 mm (5-3/8"x3-1/8"x9-3/8")					
Net weight		1.3 kg (2.8 lbs)					

DTD155 - Cordless Impact Driver

18V LXT BL Brushless 1/4"Hex Cordless
A-Mode (Assist Mode) 135 N-m (1,200
in.lbs.) Impact Driver



Belt Clip

Li-ion	Ah	5.0	4.0	3.0	1.5
Capacity		Machine Screw: M4 - M8 mm Standard Bolt: M5 - M14 High Tensile Bolt: M5 - M12 Coarse thread (in length): 22 - 90 mm			
Hex Shank		6.35 mm (1/4")			
No Load Speed (RPM)		Hard / Soft: 0 - 3,000 / 0 - 1,300			
Impacts Per Minute (IPM)		Hard / Soft: 0 - 3,900 / 0 - 1,600			
Max Fastening Torque		140 N-m (1,240 in.lbs.)			
Vibration Level		Impact tightening of fasteners of the maximum capacity of the tool: 14.0 m/s ²			
Sound Pressure Level		94 dB(A)			
Sound Power Level		105 dB(A)			
Dimensions (L x W x H)		135x79x232 mm (5-5/16"x3-1/8"x9-1/8")			
Net weight		1.2 - 1.5 kg (2.6 - 3.2 lbs)			





Cordless Impact Wrench

DTW285 1/2" (12.7 mm)



Reverse rotation auto stop mode

This mode works only with pulling the trigger fully in counterclockwise rotation. When the bolt/nut gets loosened enough, the tool stops the impact and rotation in 0.2 seconds.

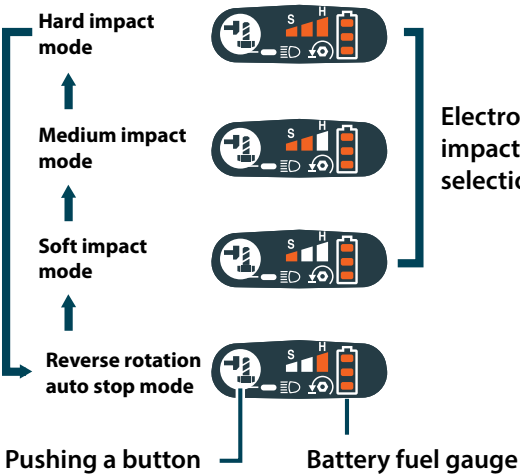

Compact design with a short overall length of 147mm (5-3/4")



Powered by Makita Li-ion batteries

with Battery fuel gauge *without Battery fuel gauge

DTW285:



- BL1850B (5.0Ah)
- BL1840B (4.0Ah)
- BL1830B (3.0Ah)
- BL1815N (1.5Ah)

Fast charger DC18RC



Charger DC18SD



DTW285RFE - Rs. 35,000
DTW285SFE3 - Rs. 45,000

Maximum Fastening torque



280 N.m

Fastening torque at 6 seconds after seating, when tightening M16 (grade F10T) high strength friction grip bolt with DTW285.

Cordless Impact Wrench DTW285 1/2" (12.7 mm)

Fastening Capacities	Standard Bolt: M10 - M20 (3/8" - 3/4") / High Tensile Bolt: M10 - M16 (3/8" - 5/8")
Square Drive	12.7 mm (1/2")
No Load Speed (RPM)	Hard / Medium / Soft: 0 - 2,800 / 0 - 2,100 / 0 - 1,600
Impacts Per Minute (IPM)	Hard / Medium / Soft: 0 - 3,500 / 0 - 2,600 / 0 - 1,800
Max Fastening Torque	280 N.m (210 ft.lbs.)
Vibration Level	Impact tightening of fasteners of the maximum capacity of the tool: 11.5 m/s ²
Sound Pressure Level / Sound Power Level	96 dB(A) / 107 dB(A)
Dimensions (L x W x H)	147x79x249 mm (5-3/4"x3-1/8"x9-3/4")
Net weight	1.5 - 1.8 kg (3.2 - 3.9 lbs)



Variable Speed



Reversing



Carrying Case



Brake



Built-in Job Light



Standard Equipment: Belt Clip, Battery, Charger



DTW1001 - Cordless Impact Wrench

18V LXT BL Brushless Cordless 3-Speed 3/4" (19 mm) 1,050 N-m (780 ft.lbs.) Impact Wrench

DTW1001RFJ - Rs. 70,000
DTW1001Z - Rs. 40,000



Hook

Li-ion Ah	5.0	4.0	3.0	1.5
Fastening Capacities	Standard Bolt: M12 - M30 (1/2" - 1-1/4") High Tensile Bolt: M10 - M24 (3/8" - 1")			
Square Drive	19 mm (3/4")			
No Load Speed (RPM)	Hard / Medium / Soft: 0 - 1,800 / 0 - 1,000 / 0 - 900			
Impacts Per Minute (IPM)	Hard / Medium / Soft: 0 - 2,200 / 0 - 2,000 / 0 - 1,800			
Max Fastening Torque	1,050 N-m (780 ft.lbs.)			
Vibration Level	Impact tightening of fasteners of the maximum capacity of the tool: 15.5 m/s ²			
Sound Pressure Level	98 dB(A)			
Sound Power Level	109 dB(A)			
Dimensions (L x W x H)	229x91x289 mm (9"x3-5/8"x11-3/8")			
Net weight	3.4 kg (7.6 lbs)			

DTW1002 - Cordless Impact Wrench

18V LXT BL Brushless Cordless 3-Speed 1/2" (12.7 mm) 1,000 N-m (740 ft.lbs.) Impact Wrench

DTW1002RFJ - Rs. 63,000
DTW1002Z - Rs. 36,000



Li-ion Ah	5.0	4.0	3.0	1.5
Fastening Capacities	Standard Bolt: M12 - M30 (1/2" - 1-1/4") High Tensile Bolt: M10 - M24 (3/8" - 1")			
Square Drive	12.7 mm (1/2")			
No Load Speed (RPM)	Hard / Medium / Soft: 0 - 1,800 / 0 - 1,000 / 0 - 900			
Impacts Per Minute (IPM)	Hard / Medium / Soft: 0 - 2,200 / 0 - 2,000 / 0 - 1,800			
Max Fastening Torque	1,000 N-m (740 ft.lbs.)			
Vibration Level	Impact tightening of fasteners of the maximum capacity of the tool: 18.0 m/s ²			
Sound Pressure Level	97 dB(A)			
Sound Power Level	108 dB(A)			
Dimensions (L x W x H)	229x91x289 mm (9"x3-5/8"x11-3/8")			
Net weight	3.3 kg (7.3 lbs)			

DTW450 - Cordless Impact Wrench

18V LXT Li-Ion Cordless 1/2" (12.7 mm) 440 N-m (325 ft.lbs.) Impact Wrench

DTW450RFE - Rs. 48,000
DTW450Z - Rs. 27,000



Hook

Li-ion Ah	5.0	4.0	3.0	1.5
Fastening Capacities	Standard Bolt: M12 - M22 (1/2" - 7/8") High Tensile Bolt: M12 - M16 (1/2" - 5/8")			
Square Drive	12.7 mm (1/2")			
No Load Speed (RPM)	1,600			
Impacts Per Minute (IPM)	2,200			
Max Fastening Torque	440 N-m (325 ft.lbs.)			
Vibration Level	Impact tightening of fasteners of the maximum capacity of the tool: 19 m/s ²			
Sound Pressure Level	94 dB(A)			
Sound Power Level	105 dB(A)			
Dimensions (L x W x H)	266x82x290 mm			
Net weight	(10-1/2"x3-1/4"x11-3/8") 3.4 kg (7.5 lbs)			



DTW251 - Cordless Impact Wrench

18V LXT Li-Ion Cordless 1/2" (12.7 mm) 230 N-m (170 ft.lbs.) Impact Wrench

DTW251RFE - Rs. 38,000



Li-ion Ah	5.0	4.0	3.0	1.5
Fastening Capacities	Standard Bolt: M10 - M16 (3/8" - 5/8") High Tensile Bolt: M10 - M14 (3/8" - 9/16")			
Square Drive	12.7 mm (1/2")			
No Load Speed (RPM)	0 - 2,100			
Impacts Per Minute (IPM)	0 - 3,200			
Max Fastening Torque	230 N-m (170 ft.lbs.)			
Vibration Level	Impact tightening of fasteners of the maximum capacity of the tool: 11.0 m/s ²			
Sound Pressure Level	94 dB(A)			
Sound Power Level	105 dB(A)			
Dimensions (L x W x H)	165x79x234 mm (6-1/2"x3-1/8"x9-1/4")			
Net weight	1.5 kg (3.3 lbs)			

DTW253 - Cordless Impact Wrench

18V LXT Li-Ion Cordless 3/8" (9.5 mm) 210 N-m (155 ft.lbs.) Impact Wrench

DTW253RFE - Rs. 38,000



Li-ion Ah	5.0	4.0	3.0	1.5
Capacity	Standard bolt: M8 - M16 (5/16" - 5/8") High strength bolt: M6 - M12 (1/4" - 1/2")			
Square drive:	9.5mm (3/8")			
Impacts per minute (ipm)	0-3,200			
No load speed (rpm)	0-2,100			
Max fastening torque	210N-m (1,860in.lbs)			
Dimensions (L x W x H)	155x79x234mm (6-1/8"x3-1/8"x9-1/4")			
Net weight	1.3kg (2.9lbs)			

DTW180 - Cordless Impact Wrench

18V LXT BL Brushless Cordless 3/8" (9.5 mm) 180 N-m (130 ft.lbs.) Impact Wrench, Reverse Rotation Auto Stop Mode

DTW180RFE - Rs. 35,000
DTW180Z - Rs. 11,000



new



Belt Clip

Li-ion Ah	5.0	4.0	2.0	1.5
Fastening Capacities	Standard Bolt: M8 - M16 (5/16" - 5/8") High Tensile Bolt: M6 - M12 (1/4" - 1/2")			
Square Drive	9.5 mm (3/8")			
No Load Speed (RPM)	Hard / Soft: 0 - 2,400 / 0 - 1,300			
Impacts Per Minute (IPM)	Hard / Soft: 0 - 3,600 / 0 - 2,000			
Max Fastening Torque	180 N-m (130 ft.lbs.)			
Dimensions (L x W x H)	144x79x235 mm (5-5/8"x3-1/8"x9-1/4")			
Net weight	1.2 kg (2.7 lbs.)			

DTW190 - Cordless Impact Wrench

18V LXT Li-Ion Cordless 13 mm (1/2") 54 N-m (480 in.lbs.) Hammer Driver Drill

DTW190RFE - Rs. 30,000
DTW190SFX1 - Rs. 25,000
DTW190SFE3 - Rs. 30,000



Li-ion Ah	5.0	4.0	3.0	1.5
Fastening Capacities	Standard Bolt: M8 - M16 (5/16" - 5/8") High Tensile Bolt: M8 - M12 (5/16" - 1/2")			
Square Drive	12.7 mm (1/2")			
No Load Speed (RPM)	0 - 2,300			
Impacts Per Minute (IPM)	0 - 3,000			
Max Fastening Torque	190 N-m (140 ft.lbs.)			
Vibration Level	Impact tightening of fasteners of the maximum capacity of the tool: 8.5 m/s ²			
Sound Pressure Level	94 dB(A)			
Sound Power Level	105 dB(A)			
Overall Length	176 mm (6-15/16")			
Net weight	1.4 - 1.8 kg (3.2 - 3.9 lbs)			



DTL063 - Cordless Angle Impact Wrench

18V LXT Li-Ion Cordless 3/8" (9.5 mm)
60 N-m Angle Impact Wrench

DTL063Z - Rs. 23,100



Li-ion	Ah	4.0	2.0	1.5
Fastening Capacities				
		Standard Bolt: M4 - M12 (5/32" - 1/2")		
		High Tensile Bolt: M4 - M8 (5/32" - 5/16")		
Square Drive		9.5 mm (3/8")		
No Load Speed (RPM)		0 - 2,000		
Impacts Per Minute (IPM)		0 - 3,000		
Max Fastening Torque		60 N-m (N/A ft.lbs.)		
Vibration Level		Impact tightening of fasteners of the maximum capacity of the tool: 16.5 m/s ²		
Sound Pressure Level		88 dB(A)		
Sound Power Level		99 dB(A)		
Dimensions (L x W x H)		387x78x116 mm (15-1/4"x3-1/16"x4-9/16")		
Net weight		1.4 - 2.0 kg (3.1 - 4.3 lbs)		



DFS250 - Cordless Screwdriver

18V LXT BL Brushless Cordless 0-2,500 RPM
High Torque Push Drive Technology
Screwdriver with LED Light, Silent Clutch

DFS250RFE - Rs. 42,000



Li-ion	Ah	4.0	2.0	1.5
Capacity				
		Coarse Thread: 4.5x90 mm (3/16" x 3-1/2")		
		Self-Drilling Screw: 6 mm (1/4")		
		Drywall Screw: 5 mm (3/16")		
Driving Shank (Hex)		6.35 mm (1/4")		
No Load Speed (RPM)		0 - 2,500		
Vibration Level		Screwdriving without Impact: 2.5 m/s ² or less		
Sound Pressure Level		72 dB(A)		
Dimensions (L x W x H)		259x79x259 mm (10-1/4"x3-1/8"x10-1/4")		
Net weight		1.5 - 1.9 kg (3.4 - 4.1 lbs)		

2 Battery, Fast Charger, Phillips Bit, Magnetic Bit Holder, Belt Clip

DFS251 - Cordless Screwdriver

18V LXT BL Brushless Cordless 0-2,500 RPM
High Torque Push Drive Technology
Screwdriver with LED Light

DFS251RFE - Rs. 42,000



Li-ion	Ah	4.0	2.0	1.5
Capacity				
		Self-Drilling Screw: 6 mm (1/4")		
		Drywall Screw: 5 mm (3/16")		
		Hex Socket Screw: 6 mm (1/4")		
Driving Shank (Hex)		6.35 mm (1/4")		
No Load Speed (RPM)		0 - 2,500		
Vibration Level		Screwdriving without Impact: 2.5 m/s ² or less		
Sound Pressure Level		72 dB(A)		
Dimensions (L x W x H)		237x79x259 mm (9-3/8"x3-1/8"x11-1/4")		
Net weight		1.5 - 1.8 kg (3.2 - 3.9 lbs)		

Magnetic Socket Bit



CLEAN

Dust Extraction System DX01 (for DHR242)

This system is designed to collect dust effectively with the on-off operation of the tool's on-off trigger switch interlocked with this system.

HEPA filter

High Efficiency Particulate Air filter is widely regarded as ultimate filter that traps all sizes of particles with an efficiency rating of 99.75%.

Dust Extraction Volume



Numbers in the chart are relative values when the capacities of the competitor H is indexed at 100.



Lightweight



Dust Box

Large dust box cover can be opened simply by pushing a single push button for easy dust cleaning.

DHR242 - Cordless Combination Hammer

18V LXT BL Brushless Cordless 24 mm (15/16") Combination Hammer, SDS-PLUS Bits

DHR242SFE3 - Rs. 50,000



Li-ion	Ah	4.0	2.0	1.5
Impact Energy		2 J		
Capacity		Concrete: 24 mm (15/16")		
		Steel: 13 mm (1/2")		
		Wood: 27 mm (1-1/16")		
Blows Per Minute (BPM)		0 - 4,700		
No Load Speed (RPM)		0 - 950		
Sound Pressure Level		90 dB(A)		
Sound Power Level		101 dB(A)		
Vibration Level		Hammer Drilling Into Concrete: 13.5 m/s ²		
		Chiselling: 10.5 m/s ²		
		Drilling: 3.5 m/s ²		
Dimensions (L x W x H)		328x85x213 mm (12-7/8"x3-3/8"x8-3/8")		
Net weight		3.1 - 3.8 kg (6.7 - 8.4 lbs)		

Tool does not come with bit.



Depth Gauge, Side Grip

DHR171 - Cordless Rotary Hammer

18V LXT BL Brushless Cordless 17 mm (11/16") Rotary Hammer, SDS-PLUS Bits

DHR171RTJ - Rs. 36,000

DHR171Z - Rs. 14,000

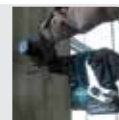

Li-ion	Ah	4.0	2.0	1.5
Impact Energy		EPTA-Procedure 05/2009: 1.2 J		
		Our experimental conditions: 1.1 J		
Capacity		Concrete: 17 mm (11/16")		
		Steel: 10 mm (3/8")		
		Wood: 13 mm (1/2")		
Blows Per Minute (BPM)		0 - 4,800		
No Load Speed (RPM)		0 - 680		
Vibration Level		Hammer Drilling Into Concrete: 9.0 m/s ²		
		Drilling Into Metal: 2.5 m/s ² or less		
Sound Pressure Level		86 dB(A)		
Sound Power Level		97 dB(A)		
Dimensions (L x W x H)		w/ BL1830B / BL1840B / BL1850B / BL1860B: 273x86x211 mm (10-3/4"x3-3/8"x8-5/16")		
Net weight		2.1 - 2.8 kg (4.6 - 6.2 lbs)		

Tool does not come with bit.

Dust Cup (country-specific), Side Grip, Depth Gauge



DHR165 - Cordless Rotary Hammer

Compact and Light weight.

DHR165RFE - Rs. 35,000
DHR165Z - Rs. 15,000



Li-ion	Ah	5.0	4.0	3.0	1.5	430	MW
Impact Energy		1.3 J					
Capacity		Concrete: 16 mm (5/8") Steel: 13 mm (1/2") Wood: 24 mm (1 5/16")					
Impacts Per Minute (IPM)		0 - 5,300					
No Load Speed (RPM)		0-1,600					
Dimensions (L x W x H)		297x79x253 mm (11-3/4"x3-1/8"x10")					
Net weight		2.3 - 3.0 kg (5.0 - 6.6 lbs)					



Tool does not come with bit.

Side grip, Depth gauge

DHR202 - Cordless Combination Hammer

Light weight although being a 3-mode rotary hammer.

DHR202RFE - Rs. 35,000



Li-ion	Ah	5.0	4.0	3.0	1.5	441	MW
Capacity		Concrete: 20mm (13/16") Steel: 13mm (1/2") Wood: 26mm (1")					
Impacts per minute (ipm)		0-4,000					
No load speed (rpm)		0-1,100					
Dimensions (L x W x H)		358x84x259mm (14-1/8"x3-5/16"x10-1/4")					
Net weight		3.2kg (7.1lbs)					



Tool does not come with bit.

Side grip, Depth gauge

DHR241 - Cordless Combination Hammer

Light weight although being a 3-mode rotary hammer.

DHR241RFE - Rs. 40,000



Li-ion	Ah	5.0	4.0	3.0	1.5	441	MW
Impact energy		1.9J					
Capacity		Concrete: 20mm (13/16") Steel: 13mm (1/2") Wood: 26mm (1")					
Impacts per minute (ipm)		0-4,000					
No load speed (rpm)		0-1,100					
Sound pressure level		86dB(A)					
Sound power level		97dB(A)					
Vibration level		hammer drilling: 12.5m/s ² chiseling: 9.5m/s ² Drilling: 2.5m/s ²					
Dimensions (L x W x H)		417x84x219mm (16-3/8"x3-5/16"x8-5/8")					
Net weight		3.2kg (7.1lbs)					



Tool does not come with bit.

Side grip, Depth gauge

DSC191 - Cordless Steel Rod Cutter

18V LXT Li-Ion Cordless 20 mm (3/4") Steel Rod Cutter

DSC191Z - Rs. 2,75,000



Li-ion	Ah	5.0	4.0	3.0	1.5		MW
Cutting Capacity		Dia: 3 - 20 mm (1/8" - 3/4")					
Cutting Speed (sec)		6.5					
Vibration Level		Cutting Rebar: 2.5 m/s ² or less					
Sound Pressure Level		80.5 dB(A)					
Sound Power Level		90.1 dB(A)					
Dimensions (L x W x H)		412x212x284 mm (16-1/5"x8-3/8"x11-1/8")					
Net weight		11.1 - 11.2 kg (24.5 - 24.6 lbs)					

Wrench, Hex wrench 4, Oil 35ml

DCS553 - Cordless Metal Cutter

18V LXT BL ADT Cordless 150 mm (5-7/8") Metal Cutter, Electric Brake, Soft Start, Dual LED Lights

DCS553RTJ - Rs. 58,000
DCS553Z - Rs. 29,000

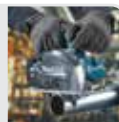

new



Li-ion	Ah	5.0	4.0	3.0	2.0	1.5	
Max Output		600 W					
Blade Diameter		150 mm (5-7/8")					
Hole Diameter		North America: 15.88 mm (5/8") Others: 20 mm (13/16")					
Max Cutting Capacity		90°: 57.5 mm (2-1/4")					
No Load Speed (RPM)		4,200					
Dimensions (L x W x H)		267x186x250 mm (10-1/2"x7-3/8"x9-7/8")					
Net weight		2.8 - 3.1 kg (6.1 - 6.8 lbs)					

TCT Saw Blade, Hex Wrench, Safety Goggles, Guide Rule

DCS551 - Cordless Metal Cutter

18V LXT BL Brushless Cordless 150 mm (5-7/8") Metal Cutter, Electric Brake, Soft Start, Dual LED Lights

DCS551Z - Rs. 30,000



Li-ion	Ah	5.0	4.0	3.0	1.5		
Blade Diameter		150 mm (5-7/8")					
Max Cutting Capacity		90°: 57.5 mm (2-1/4")					
No Load Speed (RPM)		3,900					
Vibration Level		2.5 m/s ² or less					
Sound Pressure Level		78 dB(A)					
Dimensions (L x W x H)		332x158x231 mm (13-1/8"x6-1/4"x9-1/8")					
Net weight		2.5 - 2.8 kg (5.5 - 6.2 lbs)					

TCT saw blade, Hex wrench 5, Safety goggles, Without Battery



Cordless Threaded Rod Cutter DSC102

No spark, no deburring required and low noise.

No spark, no deburring required and low noise. Nut can be immediately mounted.



LED light



with Hook



Li-ion Ah 5.0 4.0 3.0 2.0 1.5



18V / 14.4V LXT BL Brushless Cordless Threaded Rod Cutter

- Lightweight provides increased comfort for overhead cutting
- Compatible with both 18V and 14.4V LXT Li-Ion batteries
- BL motor with high power to weight and size ratio
- BL motor eliminates carbon brushes, enabling the BL motor to run cooler and more efficiently for longer life
- BL motor is electronically controlled to optimize battery energy use for up to 50% longer run time per charge

Capacity	Steel: M6 - M10 mm (W3/8")
Vibration Level	Cutting Rebar: TBA m/s ² or less
Sound Pressure Level	71 dB(A)
Dimensions (L x W x H)	199x103x308 mm (7-7/8"x4-1/16"x12-1/8")
Net weight	2.9 - 3.3 kg (6.4 - 7.3 lbs)

BL MOTOR



18V 14.4V

DSC102Z - Rs. 70,000



Cutter Blade, Hex socket head bolt, Blade Cover, Depth Gauge, Thumb screw, Hex Wrench

Cordless Steel Rod Cutter DSC250

Excellent edge cutting

Highly visible heavy-duty fluorescent material guide



Dust bag mounting part

Removable Dust Cover



Dust bag for chip powder collection



Three positioned side grip for operator is convenience.



Surface treatment of base cover prevents abrasion at cutting

Accessory
TCT Saw Blade
Blade Diameter 110mm



DSC250RT - Rs. 1,60,000
DSC250ZK - Rs. 1,50,000

Powered by 18V Li-ion battery

with Battery fuel gauge

- BL1860B: 6.0Ah
- BL1850B: 5.0Ah
- BL1840B: 4.0Ah
- BL1830B: 3.0Ah
- BL1820B: 2.0Ah
- *BL1815N: 1.5Ah
- *(without Battery fuel gauge)



Fast Charger



Cordless Steel Rod Cutter DSC250

Carrying Case

Standard Equipment :

TCT Saw Blade, Side Grip, Hex Wrench, Dust Bag, Battery, Charger

Blade Diameter	110 mm (4-5/16")
Cutting Capacity	Dia.: 10 - 25 mm (3/8" - 1")
No load speed (rpm)	2,200
Vibration Level	Cutting Rebar: 2.5 m/s ² or less
Sound Pressure Level	78dB(A)
Dimensions (L x W x H)	471x137x139mm (18-1/2"x5-3/8"x5-1/2")
Net weight	3.9-4.0 kg (8.7-8.8 lbs.)

The weight may differ depending on the attachment(s), including the battery cartridge. The lightest and heaviest combination,



DGA411 - Cordless Angle Grinder

18V LXT BL Cordless 100 mm (4") Angle Grinder, Variable Speed, Anti-Restart Function, Slide Switch Lock-On

DGA411RTE - Rs. 47,000
DGA411Z - Rs. 17,000

new **AFT ADT**



Li-ion	Ah	6.0	5.0	4.0	3.0	2.0	1.5
Wheel Diameter		100 mm (4")					
No Load Speed (RPM)		3,000 - 8,500					
Vibration Level		Surface Grinding with Anti-Vibration Side Grip: 4.0 m/s ² Disc Sanding with Anti-Vibration Side Grip: 2.5 m/s ² or less					
Sound Pressure Level		80 dB(A)					
Dimensions (L x W x H)		382x117x140 mm (15"x4-5/8"x5-1/2")					
Net weight		2.2 - 2.8 kg (4.8 - 6.1 lbs.)					



Grinding Wheel, Wheel Cover, Side Grip, Lock Nut Wrench

DGA413 - Cordless Angle Grinder

18V LXT BL Cordless 100 mm (4") Angle Grinder, Variable Speed, Anti-Restart Function, Electric Brake, Slide Switch Lock-On

DGA413Z - Rs. 17,000

new **AFT ADT** **(BRAKE)**



Li-ion	Ah	6.0	5.0	4.0	3.0	2.0	1.5
Wheel Diameter		100 mm (4")					
No Load Speed (RPM)		3,000 - 8,500					
Vibration Level		Surface Grinding with Anti-Vibration Side Grip: 4.0 m/s ² Disc Sanding with Anti-Vibration Side Grip: 2.5 m/s ² or less					
Sound Pressure Level		80 dB(A)					
Dimensions (L x W x H)		382x117x147 mm (15"x4-5/8"x5-3/4")					
Net weight		2.2 - 2.8 kg (4.9 - 6.2 lbs.)					



Grinding Wheel, Wheel Cover, Side Grip, Lock Nut Wrench

DGA417 - Cordless Angle Grinder

18V LXT BL Cordless 100 mm (4") Angle Grinder, Variable Speed, Anti-Restart Function, Electric Brake, Paddle Switch

DGA417RTE - Rs. 50,000
DGA417Z - Rs. 18,000

new **AFT ADT** **(BRAKE)**



Li-ion	Ah	6.0	5.0	4.0	3.0	2.0	1.5
Wheel Diameter		100 mm (4")					
No Load Speed (RPM)		3,000 - 8,500					
Vibration Level		Surface Grinding with Anti-Vibration Side Grip: 4.5 m/s ² Disc Sanding with Anti-Vibration Side Grip: 2.5 m/s ² or less					
Sound Pressure Level		80 dB(A)					
Dimensions (L x W x H)		382x117x146 mm (15"x4-5/8"x5-3/4")					
Net weight		2.2 - 2.9 kg (4.9 - 6.3 lbs.)					



Grinding Wheel, Wheel Cover, Side Grip, Lock Nut Wrench

DGA511 - Cordless Angle Grinder

18V LXT BL Cordless 100 mm (4") Angle Grinder, Variable Speed, Anti-Restart Function, Slide Switch Lock-On

DGA511RTE - Rs. 47,000
DGA511Z - Rs. 17,000

new **AFT ADT**



Li-ion	Ah	6.0	5.0	4.0	3.0	2.0	1.5
Wheel Diameter		125 mm (5")					
No Load Speed (RPM)		3,000 - 8,500					
Vibration Level		Surface Grinding with Anti-Vibration Side Grip: 6.0 m/s ² Disc Sanding with Anti-Vibration Side Grip: 2.5 m/s ² or less					
Sound Pressure Level		79 dB(A)					
Dimensions (L x W x H)		382x140x145 mm (15"x5-1/2"x5-3/4")					
Net weight		2.3 - 3.0 kg (5.1 - 6.6 lbs.)					



Grinding Wheel, Wheel Cover, Side Grip, Lock Nut Wrench

DGA513 - Cordless Angle Grinder

18V LXT BL Cordless 125 mm (5") Angle Grinder, Variable Speed, Anti-Restart Function, Electric Brake, Slide Switch Lock-On

DGA513RTE - Rs. 49,000
DGA513Z - Rs. 17,000

new **AFT ADT** **(BRAKE)**



Li-ion	Ah	6.0	5.0	4.0	3.0	2.0	1.5
Wheel Diameter		125 mm (5")					
No Load Speed (RPM)		3,000 - 8,500					
Vibration Level		Surface Grinding with Anti-Vibration Side Grip: 6.0 m/s ² Disc Sanding with Anti-Vibration Side Grip: 2.5 m/s ² or less					
Sound Pressure Level		79 dB(A)					
Dimensions (L x W x H)		382x140x151 mm (15"x5-1/2"x5-15/16")					
Net weight		2.4 - 3.0 kg (5.2 - 6.7 lbs.)					



Grinding Wheel, Wheel Cover, Side Grip, Lock Nut Wrench

DGA517 - Cordless Angle Grinder

18V LXT BL Cordless 125 mm (5") Angle Grinder, Variable Speed, Anti-Restart Function, Electric Brake, Paddle Switch

DGA517RTE - Rs. 50,000
DGA517Z - Rs. 18,000

new **AFT ADT** **(BRAKE)**



Li-ion	Ah	6.0	5.0	4.0	3.0	2.0	1.5
Wheel Diameter		125 mm (5")					
No Load Speed (RPM)		3,000 - 8,500					
Vibration Level		Surface Grinding with Anti-Vibration Side Grip: 5.5 m/s ² Disc Sanding with Anti-Vibration Side Grip: 2.5 m/s ² or less					
Sound Pressure Level		79 dB(A)					
Dimensions (L x W x H)		382x140x151 mm (15"x5-1/2"x5-15/16")					
Net weight		2.4 - 3.1 kg (5.2 - 6.7 lbs.)					



Grinding Wheel, Wheel Cover, Side Grip, Lock Nut Wrench



DTM51 - Cordless Multi Tool

18V LXT Li-Ion Cordless Toolless Multi Tool **DTM51RFE - Rs. 35,000**



Li-ion Ah	5.0	4.0	3.0	1.5
Oscillations Per Minute (OPM)	6,000 - 20,000			
	Left / Right / Total: 1.6° / 1.6° / 3.2°			
Oscillation Angle	Sanding: 3.0 m/s ²			
Vibration Level	Plunge Saw Blade: 7.0 m/s ² Segmental Saw Blade: 4.5 m/s ² Scraping: 5.5 m/s ²			
Sound Pressure Level	Sanding: 77 dB(A) Plunge Saw Blade: 81 dB(A) Segmental Saw Blade: 76 dB(A) Scraping: 80 dB(A)			
Sound Power Level	Plunge Saw Blade: 92 dB(A) Scraping: 91 dB(A)			
Dimensions (L x W x H)	340x80x122 mm (13-3/8"x3-1/8"x4-13/16")			
Net weight	2.0 - 2.4 kg (4.4 - 5.3 lbs)			

Oscillating multi tool accessories, Hex wrench



DLS600 - Cordless Compound Miter Saw

18V LXT BL ADT Cordless 165 mm (6-1/2") Compound Miter Saw with LED Light **DLS600RTE - Rs. 1,00,000**
DLS600Z - Rs. 70,000



Li-ion Ah	4.0	2.0	1.5
Blade Diameter	165 mm (6-1/2")		
Miter Angle	52° L / 52° R		
Bevel Angle	46° L / 46° R		
Max Cutting Capacity	90° Miter: 46 x 92 mm (1-13/16" x 3-5/8") 45° Miter, L/R: 46 x 65 mm (1-13/16" x 2-9/16")		
No Load Speed (RPM)	5,000		
Sound Pressure Level	90 dB(A)		
Sound Power Level	97 dB(A)		
Vibration Level	2.5 m/s ² or less		
Dimensions (L x W x H)	340x400x440 mm (13-3/8"x15-3/4"x17-1/4")		
Net weight	6.3 - 6.6 kg (13.9 - 14.6 lbs)		

TCT Saw Blade, Dust Bag, Vertical Vise, Hex Wrench, Triangular Rule



DHS660 - Cordless Circular Saw

18V LXT BL ADT Cordless 165 mm (6-1/2") Circular Saw, Electric Brake, Soft Start, Dual LED Lights **DHS660RFJ - Rs. 49,000**
DHS660Z - Rs. 27,000



Li-ion Ah	6.0	5.0	4.0	3.0	2.0	1.5
Blade Diameter	165 mm (6-1/2")					
Hole Diameter	15.88 / 20 mm (5/8" / 13/16")					
Max Cutting Capacity	90°: 57 mm (2-1/4") 45°: 41 mm (1-5/8") 50°: 37 mm (1-7/16")					
No Load Speed (RPM)	5,000					
Dimensions (L x W x H)	270x186x250 mm (10-5/8"x7-3/8"x9-7/8")					
Net weight	2.9 - 3.2 kg (6.3 - 7.0 lbs)					

TCT Saw Blade, Hex Wrench, Rip Fence (Guide Rule), Dust Nozzle (country-specific)



DHS661 - Cordless Circular Saw

18V LXT BL AWS ADT Cordless 165 mm (6-1/2") Circular Saw, Electric Brake, Soft Start, Dual LED Lights **DHS661RFJ - Rs. 52,000**
DHS661Z - Rs. 30,000



Li-ion Ah	6.0	5.0	4.0	3.0	2.0	1.5
Blade Diameter	165 mm (6-1/2")					
Hole Diameter	15.88 / 20 mm (5/8" / 13/16")					
Max Cutting Capacity	90°: 57 mm (2-1/4") 45°: 41 mm (1-5/8") 50°: 37 mm (1-7/16")					
No Load Speed (RPM)	5,000					
Dimensions (L x W x H)	270x186x250 mm (10-5/8"x7-3/8"x9-7/8")					
Net weight	2.9 - 3.2 kg (6.4 - 7.1 lbs)					

TCT Saw Blade, Hex Wrench, Rip Fence (Guide Rule), Dust Nozzle (country-specific)



DHS630 - Cordless Circular Saw

18V LXT Li-Ion Cordless 165 mm (6-1/2") Circular Saw, Electric Brake, Dual LED Light **DHS630Z - Rs. 30,000**



Li-ion Ah	5.0	4.0	3.0	1.5
Blade Diameter	165 mm (6-1/2")			
Max Cutting Capacity	90°: 66 mm (2-5/8") 45°: 46 mm (1-13/16")			
No Load Speed (RPM)	3,100			
Dimensions (L x W x H)	346x220x247 mm (13-5/8"x8-5/8"x9-3/4")			
Net weight	3.0 - 3.4 kg (6.6 - 7.5 lbs)			

TCT saw blade, Hex wrench, Guide rule, Dust nozzle



DJR186 - Cordless Recipro Saw

18V LXT Li-Ion Cordless Recipro Saw **DJR186RFE - Rs. 32,000**



Li-ion Ah	5.0	4.0	3.0	1.5
Length of Stroke	32 mm (1-1/4")			
Strokes Per Minute (SPM)	0 - 2,800			
Capacity	Pipe: 130 mm (5-1/8") Wood: 255 mm (10")			
Vibration Level	Cutting Boards: 13.0 m/s ² Cutting Wooden Beams: 12.5 m/s ²			
Sound Pressure Level	84 dB(A)			
Sound Power Level	95 dB(A)			
Dimensions (L x W x H)	486x81x223 mm (19-1/8"x3-3/16"x8-3/4")			
Net weight	3.5 - 3.8 kg (7.6 - 8.3 lbs)			

Recipro saw blades



DJR188 - Cordless Recipro Saw

18V LXT BL Brushless Cordless Recipro Saw **DJR188RFJ - Rs. 40,000**



Li-ion Ah	5.0	4.0	3.0	1.5
Length of Stroke	20 mm (13/16")			
Strokes Per Minute (SPM)	0 - 3,000			
Capacity	Pipe: 130 mm (5-1/8") Wood: 255 mm (10")			
Vibration Level	Cutting Boards: 15.5 m/s ² Cutting Wooden Beams: 15.0 m/s ²			
Sound Pressure Level	83 dB(A)			
Sound Power Level	94 dB(A)			
Dimensions (L x W x H)	w/ BL1815N / BL1820B: 316x81x203 mm (12-1/2"x3-3/16"x8") w/ BL1830B / BL1840B / BL1850B / BL1860B: 316x81x220 mm (12-1/2"x3-3/16"x8-5/8")			
Net weight	2.6 - 2.9 kg (5.7 - 6.4 lbs)			

Recipro Saw Blades



Recipro Saw Blades

DSD180 - Cordless Drywall Saw

Suitable for straight cut in overhead application, such as setting lights, air vents etc. **DSD180Z - Rs. 22,000**



Li-ion Ah	5.0	4.0	3.0	1.5
Strokes Per Minute (SPM)	0 - 6,000			
Length of Stroke	6 mm (1/4")			
Capacity	Drywall: 30 mm (1-3/16") Wood: 15 mm (9/16") Cutting Drywall (thickness 30mm): 2.5 m/s ²			
Vibration Level	Cutting Chip Board (thickness 15mm): 5.0 m/s ²			
Sound Pressure Level	79 dB(A)			
Dimensions (L x W x H)	263x79x291 mm (10-3/8"x3-1/8"x11-3/8")			
Net weight	1.7 - 2.0 kg (3.8 - 4.5 lbs)			

Blade, Blade cover, Base cover, Hex Wrench



Blade, Blade cover, Base cover, Hex Wrench



Cordless Trimmer

DRT50 6 mm (1/4"), 8 mm (3/8")

BL motor delivers the power and performance for corded demands



Cordless for easy maneuverability and 4 different bases for added versatility



Shaft lock, Flat-top design and Horizontally installed power supply cord provides stability for easier bit change.



Dual LED job lights illuminate cutting edge and increase visibility



Available in various combinations for added versatility

with Trimmer base



Enlarged opening section of base assembly for excellent bit visibility while maintaining durability.



with Plunge base (option)



Ergonomically contoured knob style handles



Optional Fine adjusting straight guide can be used.



with Tilt base (option)



Enlarged opening section of base assembly for excellent bit visibility.



with Offset base (option)



Able to cut close to a wall or corner-18.5mm at closest

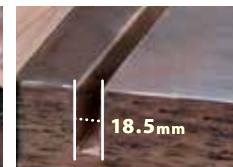

DRT50

Li-ion Ah 6.0 5.0 4.0 3.0 2.0 1.5

No Load Speed (RPM)	10,000 - 30,000
Plunge Capacity	with Trimmer Base: 0 - 40 mm (0" - 1-9/16") with Plunge Base: 0 - 35 mm (0" - 1-3/8")
Vibration Level	Rotation without Load: 2.5 m/s ² or less Cutting Grooves in MDF: 4.5 m/s ²
Sound Pressure Level	78 dB(A)
Dimensions (L x W x H)	with BL1815N / BL1820B: 134x89x208 mm (5-1/4"x3-1/2"x8-1/8") with BL1830B / BL1840B / BL1850B / BL1860B: 134x89x226 mm (5-1/4"x3-1/2"x8-7/8")
Net weight	1.8 - 2.1 kg (3.9 - 4.6 lbs)



Collet Cone, Wrench x2, Trimmer Guide

DRT50RFJ - Rs. 40,000
DRT50Z - Rs. 16,000





Cordless Rebar Tying Tool DTR180

Tying rebars automatically

Rebars can be tied automatically by only one hand in a various range of applications such as building concrete foundations.

Tying speed*
about
0.95
second

* D10 x D10, 2pcs of rebars, with 18V battery



BL MOTOR **XPT**

Continuous actuation mode

Hold the trigger and pull the contact plate against rebars



Selectable 2-Modes



Single actuation
↑↓
Continuous actuation

Adjustable rebar tying strength

According to the condition of tying material, tying strength can be adjusted in 6 stages.



Ø0.8mm Annealed tie wire dedicated for DTR180

Tie wire reel can be replaced simply by opening Reel cover.

Lock lever
Release lever



Easy to load with tie wire reel

1

Push the release lever

2

Put a reel and pass a wire through the hole

3

Release the lock lever

Typing times per 1 charge *
about

5,300

times

1 Reel *
about

120

times

* D10 x D10, 2pcs of rebars, Battery : BL1850B

Applicable rebars : D10 x D10 - (D13 x 2) x (D13 x 2)



	Typing capacity (2 pcs of rebars)		
	D10 (#3)	D13 (#4)	D16 (#5)
D10(#3)	✓	✓	✓
D13(#4)	✓	✓	✓
D16(#5)	✓	✓	✓

	Typing capacity (3 pcs of rebars)			
	D10 (#3) x D10 (#3)	D13 (#4) x D13 (#4)		
D10(#3)	✓	✓		
D13(#4)	✓	✓		
D16(#5)	✓	-		

	Typing capacity (4 pcs of rebars)			
	D10 (#3) x D10 (#3)	D13 (#4) x D13 (#4)		
D10(#3) x D10(#3)	✓	✓		
D13(#4) x D13(#4)	✓	✓		

(# means perimeter length: mm)

Accessory DTR180Z - MRP: 1,10,000

Tie wire set (Ø0.8mm)
50 pcs/ box

Part No. 199137-9

Cordless Rebar Tying Tool	DTR180
Torque Setting 6	Tie Wire ø0.8 mm
Carrying Case	Applicable Rebars D10 x D10 - (D13 x 2) x (D13 x 2)
	Vibration Level 2.5 m/s ² or less
	Sound Pressure Level 78 dB(A)
	Dimensions (L x W x H) w/ BL1815N / BL1820B: 304x93x301 mm (12"x3'-2/3"x11'-7/8") w/ BL1830B / BL1840B / BL1850B / BL1860B: 304x93x318 mm (12"x3'-2/3"x12'-1/2")
	Net weight 2.3 - 2.6 kg (5.1 - 5.7 lbs.)
	Standard Equipment : Hex Wrench, Hook

The weight may differ depending on the attachment(s), including the battery cartridge. The lightest and heaviest combination, according to EPTA-Procedure 01/2014, are shown in the table.
Items of standard equipment and specifications may vary by country or area.

Battery Powered Wheelbarrow DCU180



Powered by LXT 18V battery

Battery box is able to hold two selectable batteries



Carries all kind of heavy loads with optional carrier or bucket



Carrier type



Bucket type

can load sand, gravel, powder etc.

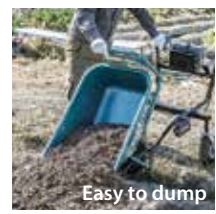



Battery Powered Wheelbarrow

DCU180

Moving cart powered by one or two LXT Li-ion batteries

Two variations: Carrier type and Bucket type

Carrier type

Size width is adjustable. If you remove Side pipes, big size materials can be loaded.



Bucket type

can load sand, gravel, powder etc.



Max loading capacity
130kgs



Max climbing angle
12°



Brake lever with locking mechanism

prevents the accidental start on a slope. (Front wheel)



Able to run with even one battery thanks to parallel battery connection.



Detachable Rear wheel



After removing rear wheels and installing Foot (left/ right), the cart can be used as an unicycle.

LED lights



- illuminate front area
- Battery case section is equipped with On-off switch

Foldable handle



can save the storage space.

DCU180Z - Rs. 1,00,000



High operating efficiency

Outer Rotor BL Motor provides high operating efficiency



Extreme Protection Technology



DCU180

Li-ion Ah 6.0 5.0 4.0 3.0 2.0 1.5

Max Run Time (min)	with BL1860B: 120
Max Load Capacity	130 kg (290 lbs.)
Traveling Speed	Forward, High / Low: 0 - 3.5 / 0 - 1.5 km/h Reverse: 0 - 1 km/h
Max Climbing Capacity	12°
Dimensions (L x W x H)	When carrier is installed / During operation: 1,315x1,060x900 mm (51-3/4"x41-3/4"x35-1/2")
Net weight	39.3 - 44.8 kg (86.5 - 98.7 lbs)

18V



Lock Key, Support Legs, Wrenches





DVP180 - Cordless Vacuum Pump

Cordless vacuum pump for air purge during installation of room air conditioner

DVP180RT - Rs. 50,000



Li-ion	Ah	5.0	4.0	3.0	1.5
Flow rate		50 L/min			
Ultimate vacuum		20 Pa (150 microns)			
Motor speed		3,840 min ⁻¹			
Oil Tank Capacity		115 mL			
Inlet port		5/16"			
Dimensions (L x W x H)		265x93x175 mm			
Net weight		(10-3/8"x3-5/8"x6-7/8") 3.5 kg			

Pump oil, Adapter

DVR850 - Cordless Concrete Vibrator

18V LXT Li-Ion Cordless 2.4 m (8.0 ft) Concrete Vibrator

DVR850Z - Rs. 48,000



Li-ion	Ah	5.0	4.0	3.0	1.5
Diameter of vibrator		25 mm (1")			
Flexible Shaft Assembly		2,400 mm (8 ft)			
Length					
Vibrations Per Minute (VPM)		12,500			
Dimensions (L x W x H)		2,683x93x250 mm			
Net weight		(105-1/2"x3-5/8"x9-7/8") 4.5 - 5.5 kg (9.9 - 12.0 lbs)			

Carrying case for battery and charger

DCG180 - Cordless Caulking Gun

Excellent work efficiency.

DCG180ZB - Rs. 20,000



Li-ion	Ah	5.0	4.0	3.0	1.5
Max pushing force		5,000N (1,100lbs)			
No load speed		0-28mm/sec. (0-66in/min.)			
Dimensions (L x W x H)		404x108x281mm			
Net weight		(15-7/8"x4-1/4"x11-1/8") 2.1kg (4.7lbs)			

Holder, Holder joint, Piston, Rubber ring, Nozzle

DPT353 - Cordless Pin Nailer

18V LXT Li-Ion Cordless Pin Nailer

DPT353RFE - Rs. 54,000
DPT353Z - Rs. 30,000

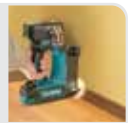

Li-ion	Ah	4.0	2.0	1.5
Capacity		Length: 15, 18, 25, 30, 35 mm		
		(5/8, 11/16, 1, 1-3/16, 1-3/8")		
		Dia.: 0.6mm (1/32")		
Magazine Capacity		130		
Vibration Level		2.5 m/s ² or less		
Sound Pressure Level		76 dB(A)		
Dimensions (L x W x H)		257x79x226mm		
Net weight		(10-1/8"x3-1/8"x8-7/8") 2.2 kg (4.9 lbs.)		



Nose Adapter, Safety Goggles, Hex Wrench

DCL501 - Cordless Cyclone Cleaner

18V LXT BL Brushless Cordless HEPA 2-Speed Cyclone Cleaner

DCL501Z - Rs. 40,000



Li-ion	Ah	4.0	2.0	1.5
Capacity		250 mL		
Continuous Use (min.)		w/ BL1860B (High): 35		
		w/ BL1860B (Low): 77		
Max Air Flow		1.2 m ³ /min		
Max Sealed Suction (water column)		10 kPa (1,020 mmH ₂ O)		
Suction Power		High: 75 W		
		Low: 25 W		
Dimensions (L x W x H)		352x189x252 mm		
Net weight		(13-7/8"x7-1/16"x9-7/8") 3.1 - 3.4 kg (6.8 - 7.5 lbs)		

Shoulder Belt, Crevice Nozzle, Cleaning Brush, Floor Nozzle, Zoom Pipe, Hose, Hose Hook

DCL182 - Cordless Cleaner

18V LXT Li-Ion Cordless 2-Speed Cleaner

DCL182RFW - Rs. 20,000



Li-ion	Ah	4.0	2.0	1.5
Capacity		Dust Bag: 500 mL		
		Paper Pack: 330 mL		
Continuous Use (min.)		w/ BL1850B (High): 33		
		w/ BL1850B (Low): 66		
Max Air Flow		1.4 m ³ /min		
Max Sealed Suction (water column)		5.4 kPa (551 mmH ₂ O)		
Suction Power		High: 30 W		
		Low: 11 W		
Dimensions (L x W x H)		1,004x115x151 mm		
Net weight		(39-1/2"x4-1/2"x5-15/16") 1.3 kg (2.8 lbs)		

Floor Nozzle, Sash Nozzle, Sash Nozzle Holder, Pipe, Dust Bag, Paper Dust Bag

DCL180 - Cordless Cleaner

18V LXT Li-Ion Cordless Cleaner

DCL180RFW - Rs. 18,000



Li-ion	Ah	4.0	2.0	1.5
Capacity		650 mL		
Continuous Use (min.)		w/ BL1830B: 20		
Max Air Flow		1.4 m ³ /min		
Max Sealed Suction (water column)		4.2 kPa (428 mmH ₂ O)		
Suction Power		30 W		
Dimensions (L x W x H)		999x114x152 mm		
Net weight		(39-1/4"x4-1/2"x6") 1.2 kg (2.7 lbs)		

Floor Nozzle, Sash Nozzle, Sash Nozzle Holder, Pipe, Filter, Prefilter

DUB183 - Cordless Blower

Long leaf blower nozzle with curved at end enables to use the machine comfortably in an upright standing posture.

DUB183Z - Rs. 6,000



Li-ion	Ah	5.0	4.0	3.0	1.5
Air volume		2.6m ³ /min			
Air speed		52m/s			
No load speed (rpm)		0-18,000			
Sound pressure level		85dB(A)			
Sound power level		95dB(A)			
Vibration level		2.5m/s ²			
Dimensions (L x W x H)		845x155x212mm			
Net weight		(33-1/4"x6-1/8"x8-3/8") 1.7kg (3.8lbs)			

Leaf blower nozzle



DVF104 - Cordless Garden Sprayer

18V LXT Li-Ion Cordless 10 L Garden Sprayer **DVF104Z - Rs. 49,000**



new



Li-ion Ah	5.0	4.0	3.0	2.0	1.5
Max Pressure	0.3 MPa (3 kgf/cm ²)				
Chemical tank	10L				
Dimensions (L x W x H)	315x225x415 mm (12-5/8"x8-7/8"x16-3/8")				
Net weight	3.8 - 4.1 kg (8.4 - 9.1 lbs)				

Upright Double-Headed Nozzle, Wide-Angle Herbicide Nozzle, Spray Pipe Holder, Shoulder Harness

DVF154 - Cordless Garden Sprayer

18V LXT Li-Ion Cordless 15 L Garden Sprayer **DVF154Z - Rs. 50,000**



new



Li-ion Ah	5.0	4.0	3.0	2.0	1.5
Max Pressure	0.3 MPa (3 kgf/cm ²)				
Chemical tank	15L				
Dimensions (L x W x H)	345x235x525 mm (13-5/8"x9-1/4"x20-3/4")				
Net weight	4.1 - 4.4 kg (9.1 - 9.7 lbs)				

Upright Double-Headed Nozzle, Wide-Angle Herbicide Nozzle, Spray Pipe Holder, Shoulder Harness



DUR182 - Cordless Grass Trimmer

Lightweight design with excellent tool balance for easy handling during operation **DUR182LRF - Rs. 39,000**
DUR182LZ - Rs. 27,500

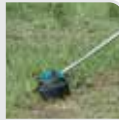

Li-ion Ah	5.0	4.0	3.0	1.5
No load speed (rpm)	3,500-6,000			
Spindle size	M8 x 1.25LH			
Sound pressure level	79dB(A)			
Sound power level	90dB(A)			
Vibration level Left handle	2.5m/s ²			
Vibration level Right handle	2.5m/s ²			
Dimensions (L x W x H)	1,843x287x253mm (72-1/2"x11-1/4"x10")			
Net Weight	3.9kg (8.6lbs)			

Battery cartridge, Single harness, Nylon cutting head, Wrenches, Safety goggles

DUR187 - Cordless Grass Trimmer

18V LXT BL ADT Cordless Grass Trimmer, Loop Handle **DUR187LRF - Rs. 49,000**



Li-ion Ah	4.0	2.0	1.5
Cutting Width	Nylon Cutting Head: 300 mm (11-3/4") Plastic Blade: 255 mm (10")		
No Load Speed (RPM)	High / Medium / Low / ADT Mode: 6,000 / 5,000 / 4,000 / 4,000 - 6,000		
Spindle Size	M8 x 1.25 LH		
Sound Pressure Level	Nylon Cutting Head: 74 dB(A)		
Sound Power Level	Nylon Cutting Head: 84 dB(A)		
Sound Pressure Level	Plastic Blade: 79 dB(A)		
Sound Power Level	Plastic Blade: 88 dB(A)		
Vibration Level	Front / Rear: 2.5 / 2.5 m/s ² or less		
Dimensions (L x W x H)	1,791x258x232 mm (70-1/2"x10-1/8"x9-1/8")		
Max Run Time (min)	Nylon Cutting Head, BL1860B: 168 Plastic Blade, BL1860B: 219		
Net weight	3.4 - 3.7 kg (7.5 - 8.2 lbs)		

Safety Goggles, Shoulder Harness, Nylon Cutting Head, Plastic Blade, Accessory Bag, Hex Wrench

DUM604 - Cordless Grass Shear

18V LXT Li-Ion Cordless 16 cm (6-5/16") Grass Shear **DUM604SY - Rs. 20,000**
DUM604Z - Rs. 9,000



Li-ion Ah	5.0	4.0	3.0	1.5
Cutting Width	160 mm (6-5/16")			
Depth Adjustment	15, 20, 25 mm (9/16", 13/16", 1")			
Strokes Per Minute (SPM)	2,500			
Continuous Use (min.)	with BL1860B / BL1850B / BL1840B / BL1830B / BL1820B / BL1815N: 250 / 200 / 160 / 125 / 80 / 60			
Sound Pressure Level	76 dB(A)			
Vibration Level	2.5 m/s ² or less			
Dimensions (L x W x H)	337x177x131 mm (13-1/4"x7"x5-1/8")			
Net weight	1.4 - 1.8 kg (3.2 - 4.0 lbs)			

Grass Receiver, Blade Cover



DUC254 - Cordless Chain Saw

18V LXT BL Brushless Cordless 25 cm (10") Chain Saw **DUC254Z - Rs. 30,000**



Li-ion Ah	2.6	2.2
Guide Bar Length	250 mm (10")	
Cutting length	240 mm (N/A)	
Chain Pitch	3/8"	
Chain Gauge	1.1 mm (0.043")	
Chain Speed	0 - 24 m/s (0 - 1,440 m/min) (0 - 4,720 FPM)	
Chain Oil Tank Volume	140 mL (4.7 US oz)	
Max Output	570 W	
Sound Pressure Level	92.2 dB(A)	
Sound Power Level	103.2 dB(A)	
Vibration Level	Cutting Wood: 3.1 m/s ²	
Dimensions (L x W x H)	w/o Guide Bar: 258x184x191 mm (10-1/8"x7-1/4"x7-1/2")	
Net weight	2.8 - 3.2 kg (6.2 - 6.9 lbs.)	

Saw Chain, Guide Bar, Guide Bar Cover, Wrench, Accessory Bag



DML805 - Corded and Cordless LED Worklight

18V LXT Li-Ion Cordless/Corded 20 LED Worklight, 750 Lumens

DML805 - Rs. 13,000



Li-ion	Ah	5.0	4.0	3.0	1.5
Run Time (hrs)		Up to: 17			
Illuminance		at 0.5m from the light source Hi:			
		1,150 lx, Lo: 750 lx			
Luminous flux		at 1m from the light source Hi:			
		300 lx, Lo: 200 lx			
Net weight		Hi: 750 lm, Lo: 450 lm			
		2.3 - 2.7 kg (5.1 - 5.9 lbs)			

DML808 - LED Flashlight

18V LXT Li-Ion LED Flashlight, 190 Lumens

DML808 - Rs. 5,200



Li-ion	Ah	5.0	4.0	3.0	1.5
Run Time (hrs)		Up to: 32			
Luminous flux		190 lm			
Illuminance		at 1m from the light source			
		170 - 4,500 lx			
Dimensions (L x W x H)		with BL1815N / BL1820B:			
		280x79x101 mm (11"x3-1/8"x4")			
Net weight		with BL1830B / BL1840B / BL1850B / BL1860B:			
		297x79x119 mm (11-3/4"x3-1/8"x4-11/16")			
		0.73 - 1.09 kg (1.6 - 2.4 lbs)			

Strap Hook

DML807 - Cordless LED Flashlight

18V LXT Li-Ion 21 LED Flashlight, 710 Lumens

DML807 - Rs. 7,800



Li-ion	Ah	5.0	4.0	3.0	1.5
Run Time (hrs)		Up to: 43			
Main light (on bar side)		Luminous flux (Full brightness):			
		710 lm			
Illuminance (Full brightness):		340 lx			
		Luminous flux (Half brightness):			
Illuminance (Half brightness):		340 lm			
		310 lx			
Sub light (on top side)		Luminous flux: 130 lm			
		Illuminance: 1,900 lx			
Dimensions (L x W x H)		414x79x155 mm			
		(16-1/4"x3-1/8"x6-1/8")			
Net weight		0.72 - 1.1 kg (1.6 - 2.4 lbs)			

DML806 - Cordless LED Flashlight

18V LXT Li-Ion 21 LED Flashlight, 620 Lumens

DML806 - Rs. 6,080



Li-ion	Ah	5.0	4.0	3.0	1.5
Run Time (hrs)		Up to: 71			
Dimensions (L x W x H)		365x78x119 mm (14-3/8"x3-1/16"x4-11/16")			
Net weight		0.69 - 1.1 kg (1.5 - 2.4 lbs)			



DML801 - LED Flashlight

18V LXT Li-Ion 12 LED Flashlight, 240 Lumens **DML801** - Rs. 4,350



Shoulder Strap

Li-ion	Ah	5.0	4.0	3.0	1.5
Run Time (hrs)	Up to:	48			
Dimensions (L x W x H)		380x79x116 mm (15"x9-11/16"x4-9/16")			
Net weight		0.61 - 0.98 kg (1.4 - 2.2 lbs)			

DML185 - Rechargeable Flashlight

18V LXT Li-Ion Flashlight **DML185** - Rs. 2,270



Li-ion	Ah	5.0	4.0	3.0	1.5
Max Run Time (min)		550			
Overall Length		284 mm (11-1/8")			
Net weight		0.71 - 1.03 kg (1.6 - 2.3 lbs)			

DML800 - Rechargeable Flashlight

18V LXT Li-Ion LED Flashlight, 100 Lumens **DML800** - Rs. 3,480



Head Band

Li-ion	Ah	5.0	4.0	3.0	1.5
Run Time (hrs)	Up to:	30			
Dimensions (L x W x H)		151x76x88 mm (5-15/16"x3"x3-1/2")			
Net weight		0.53 - 0.91 kg (1.2 - 2.0 lbs)			



DML803 - LED Flashlight

18V LXT Li-Ion LED Flashlight, 170 Lumens **DML803** - Rs. 4,680



Li-ion	Ah	5.0	4.0	3.0	1.5
Run Time (hrs)	Up to:	36			
Dimensions (L x W x H)		133x81x72 mm (5-1/4"x3-3/16"x2-13/16")			
Net weight		0.56 - 0.92 kg (1.2 - 2.1 lbs)			

DML186 - LED Flashlight

18V LXT Li-Ion 6 LED Flashlight **DML186** - Rs. 1,490



Li-ion	Ah	5.0	4.0	3.0	1.5
Run Time (hrs)	Up to:	114			
Dimensions (L x W x H)		151x81x61 mm (5-7/8"x3-3/16"x2-3/8")			
Net weight		0.51 - 0.83 kg (1.1 - 1.8 lbs)			

DCF102 - Cordless Fan

18V / 14.4V LXT Li-Ion Cordless 180 mm (7-1/8") Automatic Swing Fan **DCF102Z** - Rs. 8,000



new



Li-ion	Ah	4.0	2.0	1.5
Continuous Use (min.)	w/ BL1860B Low / Medium / High:	1,270 / 705 / 575		
	w/ BL1815N Low / Medium / High:	295 / 165 / 135		
	w/ BL1460B Low / Medium / High:	860 / 465 / 365		
	w/ BL1415N Low / Medium / High:	245 / 135 / 105		
	High / Medium / Low:	4.6 / 3.8 / 3.0 L/min		
Air Flow		185x272x284 mm (7-1/4"x10-3/10"x11-1/8")		
Dimensions (L x W x H)		1.3 - 2.0 kg (2.9 - 4.4 lbs.)		
Net weight				



18V

Lithium-ion



DF457D - Cordless Driver Drill

18V Li-Ion Cordless 13 mm (1/2") 38 N-m (340 in.lbs.) Driver Drill, G-Battery **DF457DWE - Rs. 20,000**



(+)(-) Bit

Li-ion	Ah	1.5			
Capacity	Steel: 13 mm (1/2") Wood: 36 mm (1-7/16")				
No Load Speed (RPM)	High: 0 - 1,400 Low: 0 - 400				
Max Fastening Torque	Hard / Soft: 42 / 24 N-m				
Max lock torque	38 N-m (340 in.lbs.)				
Dimensions (L x W x H)	221x83x240 mm (8-3/4"x3-1/4"x9-1/2")				
Net weight	1.7 kg (3.7 lbs)				

HP457D - Cordless Hammer Driver Drill

18V Li-Ion Cordless 13 mm (1/2") 38 N-m (340 in.lbs.) Hammer Driver Drill, G-Battery **HP457DWE - Rs. 20,500**



(+)(-) Bit

Li-ion	Ah	1.5			
Capacity	Steel / Wood / Masonry: 13 / 36 / 13 mm (1/2" / 1-7/16" / 1/2")				
Impacts Per Minute (IPM)	High / Low: 0 - 21,000 / 0 - 6,000				
No Load Speed (RPM)	High / Low: 0 - 1,400 / 0 - 400				
Max Fastening Torque	Hard / Soft: 42 / 24 N-m (370 / 210 in.lbs.)				
Max lock torque	38 N-m (340 in.lbs.)				
Vibration Level	Hammer Drilling Into Concrete: 7.0 m/s ² Drilling Into Metal: 2.5 m/s ² or less				
Sound Pressure Level	81 dB(A)				
Sound Power Level	92 dB(A)				
Dimensions (L x W x H)	239x83x240 mm (9-3/8"x3-1/4"x9-1/2")				
Net weight	1.7 kg (3.7 lbs)				

TD127D - Cordless Impact Driver

18V Li-Ion Cordless 140 N-m (1,240 in.lbs.) Impact Driver, G-Battery **TD127DWE - Rs. 21,000**



Li-ion	Ah	1.5			
Capacity	Machine Screw: M4 - M8 (5/32" - 5/16") Standard Bolt: M5 - M14 (3/16" - 9/16") High Tensile Bolt: M5 - M12 (3/16" - 1/2") Coarse thread (in length): 22 - 125 mm (7/8" - 4-7/8")				
No Load Speed (RPM)	0 - 2,300				
Impacts Per Minute (IPM)	0 - 3,000				
Max Fastening Torque	140 N-m (1,240 in.lbs.)				
Dimensions (L x W x H)	173x82x225 mm (6-13/16"x3-1/4"x8-7/8")				
Net weight	1.5 kg (3.2 lbs)				

CL183D - Cordless Cleaner

18V Li-Ion Cordless Cleaner, G-Battery **CL183DWE - Rs. 13,000**



Li-ion	Ah	1.5			
Capacity	600 mL				
Continuous Use (min.)	w/ BL1815G: 30				
Max Air Flow	1.3 m ³ /min				
Max Sealed Suction (water column)	2.6 kPa (270 mmH ₂ O)				
Suction Power	17 W				
Dimensions (L x W x H)	966x102x148 mm (38"x4"x5-7/8")				
Net weight	1.2 kg (2.6 lbs.)				

Floor Nozzle, Sash Nozzle, Sash Nozzle Holder, Pipe, Filter, Prefilter



12V^{max} LITHIUM-ION

4.0Ah 2.0Ah 1.5Ah

EXPAND YOUR LITHIUM-ION LINEUP

- Rechargeable Green Multi Line Laser SK209GD / SK312GD
- Heated Jacket CJ102D
- Heated Vest CV101D
- Fan Jacket DFJ202 / DFJ203 / DFJ300 / DFJ301 / DFJ400 / DFJ401
- Fan CF100D
- LED Flashlight ML103 / ML104 / ML105 / ML106
- Hedge Trimmer UH201D
- Job Site Radio DMR107 / DMR108 / DMR109 / DMR110 / MR052
- Job Site Speaker DMR200 / DMR201 / DMR202
- Laser Level SK105GD / SK105D
- Driver Drill DF332D / DF032D / DF331D / DF031D
- Hammer Driver Drill HP332D / HP331D
- Angle Drill DA332D / DA333D
- Impact Driver TD111D / TD110D
- Rotary Hammer HR140D / HR166D
- Angle Impact Driver TL064D / TL065D
- Multi Cutter CP100D
- Circular Saw HS301D
- Recipro Saw JR105D / JR103D
- Cutter CC301D
- Drywall Saw SD100D
- Jig Saw JV101D / JV102D / JV103D
- Pin Nailer PT354D
- Adapter for USB ADP08
- Stapler ST113D
- Grass Shear UM600D
- Grass Trimmer UR100D
- Caulking Gun CG100D
- Job Site Radio
- Job Site Speaker
- Driver Drill
- Hammer Driver Drill
- Impact Driver
- Rotary Hammer
- Angle Impact Driver
- Multi Cutter
- Circular Saw
- Recipro Saw
- Cutter
- Drywall Saw
- Jig Saw
- Pin Nailer
- Adapter for USB
- Stapler
- Grass Shear
- Grass Trimmer
- Caulking Gun

Fast Charging 22 minutes

DC18RE

to fully charge a 1.5Ah slide Li-ion battery



Optimum Charging System

Forced air cooling system DC10SB only

- Stand-by time until the charge starts can be greatly shortened by using charger DC10SB equipped with a built-in cooling fan.
- Effectively cools down every battery cell with the forced air cooling system and the heat sinks.



Cooling fan



Compact and lightweight design

DC10WD provides higher charging performance than DC10WB, but with a more compact and lightweight design. (It's same charging time(50min.) as DC10WB for 1.3Ah battery although the new battery is 1.5Ah.)



Charging status indicator

shows the charging status of a battery being charged in 2 stages: less than 80% and 80% or more.



Wall mountable for charging

can be mounted on the wall for charging, allowing the user to obtain maximum working space on workbench.



Li-ion Battery

Multi-Contact Slide-type Terminal

- Ensures stable contact with tool even under extreme vibration.
- Allows tools to be equipped with an ergonomic handle design.



Battery fuel gauge (BL1021B, BL1041B)

The power remaining in the battery can be indicated in 4 stages simply by pushing a button.

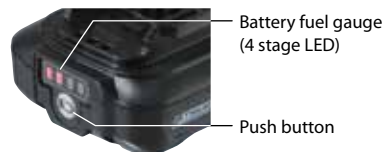

Charges LXT and CXT battery alternatively

Compatible batteries are:
14.4V/18V LXT batteries &
12V max CXT batteries



Li-ion Battery & Charger Time Reference, Compatibility Chart

	 BL1016 12Vmax 1.5Ah	 BL1021B 12Vmax 2.0Ah with Battery fuel gauge	 BL1041B 12Vmax 4.0Ah with Battery fuel gauge
 DC10SB for 12Vmax 	22 min	30 min	60 min
 DC10WD for 12Vmax	50 min	70 min	130 min



Green Laser Series SK312GD / SK209GD SK106GD / SK105GD

High brightness green laser for increased visibility at bright site



Rechargeable Green Multi Line Laser

Horizontal / 3-Vertical lines

SK312GD

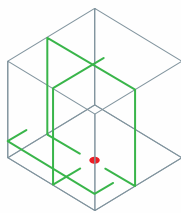

Horizontal / 2-Vertical lines

SK209GD

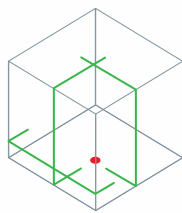

Rechargeable Green Cross Line Laser

Cross line + Point

SK106GD

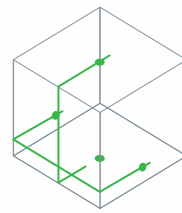

Cross line

SK105GD

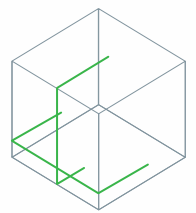

12V max Lithium-ion Battery



Green Laser Series

Powered by the following 12V max slide CXT Li-ion batteries

1.5Ah : BL1016, 2.0Ah : BL1021B, 4.0Ah : BL1041B

SK312GD / SK209GD

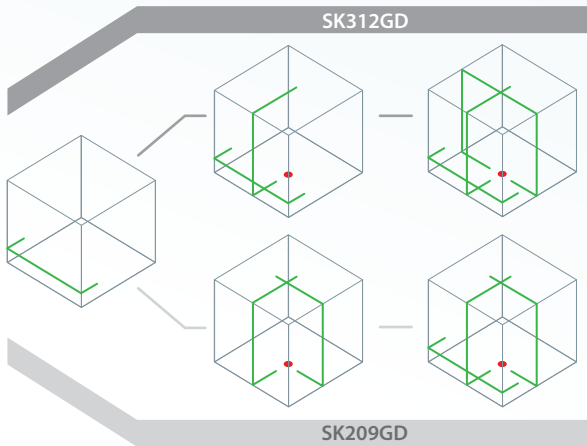

Long continuous operation

*at max output

SK312GD / SK209GD

10 / 15h

BL1016
1.5Ah

14 / 20h

BL1021B
2.0Ah

28 / 40h

BL1041B
4.0Ah

Brightness indicator

Bright

Normal

Eco mode



Line beam mode selection

Laser line selection

Line beam mode memory

When the power is turned ON, the laser beam mode will be the same mode as the last time turned OFF.

Large handle

prevents the tool from falling.

Adjustment screw leg

Horizontal line can be adjusted at any places

Fine adjustment knob

fine-adjusted from either side by turning fine-adjustment knob

XPT

Extreme Protection

For use in outdoor applications, protection against dripping water is enhanced.

Leveling accuracy

±1mm/10m

SK312GD / SK209GD

Shock absorbing construction

prevents the tool from vibration during transport



Spring

Rubber foot

Aluminum carrying case



ALL PRODUCTS

High brightness green laser

for increased visibility at bright site

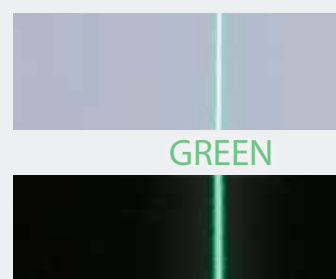

GREEN



SK106GD / SK105GD

SK106GD / SK105GD

with point (SK106GD only)

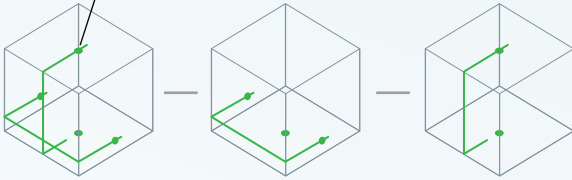

Long continuous operation

*at max output

SK106GD / SK105GD

7 / 7h

BL1016
1.5Ah

10 / 10h

BL1021B
2.0Ah

20 / 20h

BL1041B
4.0Ah



Laser line selection and on / off switch

Brightness indicator
Bright
Eco mode

Adapter with magnet

for SK105GD / SK105D



for SK106GD / SK106D



Technology

Resistant to vibrations or harsh conditions from dust and dirt.

Leveling accuracy

±3mm / 10m

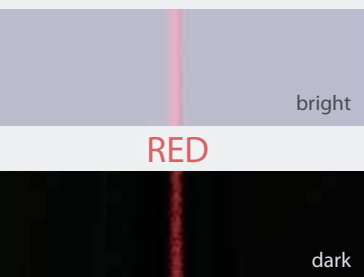

SK106GD / SK105GD

Pendulum lock

Pendulum lock enables slope incline applications for increased versatility



Lock switch

Soft bag



Makita Laser Series

Line-Point Laser
SK103PZ



Cross Line Laser
SK104Z



Laser Level
SKR200Z



Cross Line Laser
SK106D / SK105D



Accessories

Laser Receiver LDG-3
TK0LDG301F
SK312GD / SK209GD



Laser Receiver LDX1
LE00855702
SK106GD / SK105GD
SK106D / SK105D



Large soft bag
832173-9
SK106GD / SK105GD
SK106D / SK105D



SK106GD
BL1021B x2
DC10SB
Wall Mount
Adapter

Adapter for USB
ADP05



Power supply cable
199006-4
SK312GD / SK209GD
199178-5
SK106GD / SK105GD



Hand strap set
199007-2



Min tripod
TK0LM1001F



Tripod 1800
TK0LM4001F



Tripod 2900
TK0LM5030F



Wall mount
TK000ET03F
SK312GD / SK209GD



Wall mount
Wall and ceiling adapter for universal applications with height adjustment function

LE00855706
SK106GD / SK105GD
SK106D / SK105D



SK312GDZ - Rs. 1,67,000
SK209GDZ - Rs. 1,23,000

SK106GDZ - Rs. 65,000
SK105GDZ - Rs. 40,000

Rechargeable Green Multi Line Laser SK312GD / SK209GD

	SK312GD	SK209GD
Measuring range	-	-
Measuring range w/ detector	-	-
Leveling accuracy	±1 mm / 10 m	±1 mm / 10 m
Self-leveling range	±2°	±2°
Laser fan angle	Horizontal: 110° Vertical: 130°	Horizontal: 110° Vertical: 130°
Number of laser lines	3	3
Laser type	Laser class 2: 515 nm	Laser class 2: 515 nm
Operating temperature	-10 - 40 °C	-10 - 40 °C
Tripod thread	5/8"	5/8"
Operating Time (Approx. Hours)	10-28	15-40
Dimensions (L x W x H)	w/ BL1016/BL1021B: 122x110x225 mm	w/ BL1016/BL1021B: 122x110x225 mm
	w/ BL1041B: 122x130x225 mm	w/ BL1041B: 122x130x225 mm
Net weight	1.5 - 1.6 kg (3.3 - 3.5 lbs)	1.5 - 1.6 kg (3.3 - 3.5 lbs)

Standard Equipment: Laser Viewing Glass, Shoulder Strap, Storage Case
Dimensions (with carry handle in retracted position)

Rechargeable Green Cross Line Laser SK106GD / SK105GD

SK106GD	SK105GD
Up to: 35 m	Up to: 35 m
Up to: 80 m	Up to: 80 m
±3 mm / 10 m	±3 mm / 10 m
±4°	±4°
Horizontal: 180° Vertical: 170°	Horizontal: 180° Vertical: 160°
2	2
Laser class 2: 525 nm	Laser class 2: 525 nm
-10 - 50 °C	-10 - 50 °C
1/4" / 5/8"	1/4" / 5/8"
7 - 20	7 - 20
w/ BL1016/BL1021B: 138x64x102 mm (5-7/16"x2-1/2"x4")	w/ BL1016/BL1021B: 1138x64x102 mm (5-7/16"x2-1/2"x4")
w/ BL1041B: 157x64x102 mm (6-3/16"x2-1/2"x4")	w/ BL1041B: 157x64x102 mm (6-3/16"x2-1/2"x4")
0.69 - 0.85 kg (1.5 - 1.9 lbs.)	0.67 - 0.84 kg (1.5 - 1.9 lbs.)

Standard Equipment: Soft bag, Adapter, Target Plate

The weight may differ depending on the attachment(s), including the battery cartridge.



Cordless 12V

DF331D - Cordless Driver Drill

12V max CXT Li-Ion Cordless 10 mm (3/8") 28 N-m (250 in.lbs.) Driver Drill / 6.35 mm (1/4") Driver Drill

DF331DWAE - Rs. 16,500
DF331DWYE - Rs. 15,000
DF331DZ - Rs. 6,000



Li-ion	AH	4.0	2.0	1.5
Capacity		Steel / Wood : 10 / 21 mm (3/8" / 13/16")		
Chuck capacity		0.8 - 10 mm (1/32 - 3/8")		
No Load Speed (RPM)		High / Low : 0 - 1,700 / 0 - 450		
Max Fastening Torque		Hard / Soft: 30 / 14 N-m (270 / 130 in.lbs.)		
Max lock torque		28 N-m (250 in.lbs.)		
Vibration Level		Drilling Into Metal : 2.5 m/s ² or less		
Sound Pressure Level		70 dB(A) or less		
Max Output		170 W		
Dimensions (L x W x H)		189x66x209 mm (7-7/16"x2-5/8"x8-1/4")		
Net weight		1.1 - 1.3 kg (2.4 - 2.8 lbs)		



Battery cover, Phillips Bit, Belt clip

DF332D - Cordless Driver Drill

12V max CXT BL Brushless Cordless 10 mm (3/8") 32 N-m (280 in.lbs.) Driver Drill / 6.35 mm (1/4") Driver Drill

DF332DWYE - Rs. 21,000
DF332DZ - Rs. 12,000



Li-ion	AH	4.0	2.0	1.5
Capacity		Steel / Wood: 10 / 28 mm (3/8" / 1-1/8")		
Chuck capacity		0.8 - 10 mm (1/32 - 3/8")		
No Load Speed (RPM)		High / Low: 0 - 1,500 / 0 - 450		
Max Fastening Torque		Hard / Soft: 35 / 21 N-m (310 / 190 in.lbs.)		
Max lock torque		32 N-m (280 in.lbs.)		
Vibration Level		Drilling Into Metal: 2.5 m/s ² or less		
Sound Pressure Level		72 dB(A)		
Max Output		250 W		
Dimensions (L x W x H)		154x66x217 mm (6-1/16"x2-5/8"x8-1/2")		
Net weight		1.0 - 1.2 kg (2.3 - 2.6 lbs)		



Battery cover, Belt clip, Phillips bit

DF031D - Cordless Driver Drill

12V max CXT BL Brushless Cordless 28 N-m (280 in.lbs.) Driver Drill / 6.35 mm (1/4") Hex Driver Drill

DF031DWAE - Rs. 15,000
DF031DWYE - Rs. 13,500
DF031DZ - Rs. 4,500



Li-ion	AH	4.0	2.0	1.5
Capacity		Steel / Wood : 10 / 21 mm (3/8" / 13/16")		
Chuck capacity		6.35 mm (1/4")		
No Load Speed (RPM)		High / Low : 0 - 1,700 / 0 - 450		
Max Fastening Torque		Hard / Soft: 30 / 14 N-m (270 / 130 in.lbs.)		
Max lock torque		28 N-m (250 in.lbs.)		
Vibration Level		Drilling Into Metal : 2.5 m/s ² or less		
Sound Pressure Level		70 dB(A) or less		
Max Output		170 W		
Dimensions (L x W x H)		157x66x209 mm (6-3/16"x2-5/8"x8-1/4")		
Net weight		0.94 - 1.1 kg (2.1 - 2.5 lbs)		



Battery cover, Belt clip, Phillips bit

DF032D - Cordless Driver Drill

12V max CXT BL Brushless Cordless 32 N-m (280 in.lbs.) Driver Drill / 6.35 mm (1/4") Hex Driver Drill

DF032DWYE - Rs. 20,000
DF032DZ - Rs. 11,000



Li-ion	AH	4.0	2.0	1.5
Capacity		Steel / Wood: 10 / 28 mm (3/8" / 1-1/8")		
Chuck capacity		6.35 mm (1/4")		
No Load Speed (RPM)		High / Low: 0 - 1,500 / 0 - 450		
Max Fastening Torque		Hard / Soft: 35 / 21 N-m (310 / 190 in.lbs.)		
Max lock torque		32 N-m (280 in.lbs.)		
Vibration Level		Drilling Into Metal: 2.5 m/s ² or less		
Sound Pressure Level		71 dB(A)		
Max Output		250 W		
Dimensions (L x W x H)		124x66x217 mm (4-7/8"x2-5/8"x8-1/2")		
Net weight		0.88 - 1 kg (1.9 - 2.3 lbs)		



Battery cover, Belt clip, Phillips bit

HP331D - Cordless Hammer Driver Drill

12V max CXT Li-Ion Cordless 10 mm (3/8") 28 N-m (250 in.lbs.) Hammer Driver Drill

HP331DWAE - Rs. 17,500
HP331DWYE - Rs. 16,000



Li-ion	AH	4.0	2.0	1.5
Capacity		Steel / Wood / Masonry : 10 / 21 / 8 mm (3/8" / 13/16" / 5/16")		
No Load Speed (RPM)		High / Low: 0 - 25,500 / 0 - 6,750		
Max Fastening Torque		High / Low: 0 - 1,700 / 0 - 450		
Max lock torque		Hard / Soft: 30 / 14 N-m (270 / 130 in.lbs.) 28 N-m (250 in.lbs.)		
Vibration Level		Hammer Drilling Into Concrete: 8.0 m/s ² Drilling Into Metal: 2.5 m/s ²		
Sound Pressure Level		81 dB(A)		
Sound Power Level		92 dB(A)		
Dimensions (L x W x H)		201x66x209 mm (7-7/8"x2-5/8"x8-1/4")		
Net weight		1.1 - 1.3 kg (2.5 - 2.9 lbs)		



Battery cover, Belt clip, Phillips bit

HP332D - Cordless Hammer Driver Drill

12V max CXT BL Brushless Cordless 10 mm (3/8") 32 N-m (280 in.lbs.) Hammer Driver Drill

HP332DWYE - Rs. 22,000



Li-ion	AH	4.0	2.0	1.5
Capacity		Steel / Wood / Masonry: 10 / 28 / 8 mm (3/8" / 1-1/8" / 5/16")		
Chuck capacity		0.8 - 10 mm (1/32 - 3/8")		
No Load Speed (RPM)		High / Low: 0 - 22,500 / 0 - 6,750		
Max Fastening Torque		High / Low: 0 - 1,500 / 0 - 450		
Max lock torque		Hard / Soft: 35 / 21 N-m (310 / 190 in.lbs.)		
Vibration Level		32 N-m (280 in.lbs.) Hammer Drilling Into Concrete: 12.5 m/s ² Drilling Into Metal: 2.5 m/s ² or less		
Sound Pressure Level		82 dB(A)		
Sound Power Level		93 dB(A)		
Dimensions (L x W x H)		168x66x217 mm (6-5/8"x2-5/8"x8-1/2")		
Net weight		1.1 - 1.3 kg (2.4 - 2.8 lbs)		



Battery cover, Belt clip, Phillips bit

DA332D - Cordless Angle Drill

12V max CXT Li-Ion Cordless 10 mm (3/8") Angle Drill, Keyed Chuck

DA332DWAE - Rs. 19,500
DA332DWYE - Rs. 18,000
DA332DZ - Rs. 9,000



Li-ion	AH	4.0	2.0	1.5
Capacity		Steel: 10 mm (3/8") Wood: 12 mm (1/2")		
No Load Speed (RPM)		0 - 1,100		
Head Height		63 mm (2-1/2")		
Center Height		23.5 mm (15/16")		
Vibration Level		Drilling Into Metal: 2.5 m/s ² or less		
Vibration K Factor		70 dB(A) or less		
Sound Pressure Level		70 dB(A) or less		
Dimensions (L x W x H)		w/ BL1016/BL1021B: 313x68x86 mm (12-3/8"x2-11/16"x3-3/8") w/ BL1041B: 332x68x86 mm (13-1/8"x2-11/16"x3-3/8")		
Net weight		1.2 - 1.3 kg (2.6 - 2.9 lbs)		



Chuck Key, Chuck Key Holder, Bit, Belt Clip

DA333D - Cordless Angle Drill

12V max CXT Li-Ion Cordless 10 mm (3/8") Angle Drill, Keyless Chuck

DA333DWAE - Rs. 18,500
DA333DWYE - Rs. 17,000
DA333DZ - Rs. 8,000



Li-ion	AH	4.0	2.0	1.5
Capacity		Steel: 10 mm (3/8") Wood: 12 mm (1/2")		
No Load Speed (RPM)		0 - 1,100		
Head Height		84 mm (3-5/16")		
Center Height		23.5 mm (15/16")		
Vibration Level		Drilling Into Metal: 3.0 m/s ² or less		
Sound Pressure Level		70 dB(A) or less		
Dimensions (L x W x H)		w/ BL1016/BL1021B: 313x68x95 mm (12-3/8"x2-11/16"x3-3/4") w/ BL1041B: 332x68x95 mm (13-1/8"x2-11/16"x3-3/4")		
Net weight		1.2 - 1.4 kg (2.7 - 3.0 lbs)		



Bit, Belt Clip



TD111D - Cordless Impact Driver

12V max CXT BL Brushless Cordless A-Mode (Assist Mode) 135 N-m (1,200 in.lbs.) (1/4" Hex) Impact Driver

TD111DWYE - Rs. 20,000
TD111DWAE - Rs. 21,500
TD111DZ - Rs. 11,000



Li-ion	Ah	4.0	2.0	1.5
Capacity		Machine Screw: M4 - M8 mm Standard Bolt: M5 - M14 High Tensile Bolt: M5 - M12 Coarse thread (in length): 22 - 90 mm		
Hex Shank		6.35 mm (1/4")		
No Load Speed (RPM)		Hard / Soft: 0 - 3,000 / 0 - 1,300		
Impacts Per Minute (IPM)		Hard / Soft: 0 - 3,900 / 0 - 1,600		
Max Fastening Torque		135 N-m (1,200 in.lbs.)		
Vibration Level		Impact tightening of fasteners of the maximum capacity of the tool: 12.5 m/s ²		
Sound Pressure Level		94 dB(A)		
Sound Power Level		105 dB(A)		
Dimensions		135x66x210 mm		
(L x W x H)		(5-5/16"x2-5/8"x8-1/4")		
Net weight		0.97 - 1.1 kg (2.1 - 2.5 lbs)		

BL MOTOR

Belt clip, Phillips bit

TD110D - Cordless Impact Driver

12V max CXT Li-Ion Cordless 110 N-m (970 in.lbs.) (1/4" Hex) Impact Driver

TD110DWAE - Rs. 16,000
TD110DWYE - Rs. 14,500
TD110DZ - Rs. 5,500



Li-ion	Ah	4.0	2.0	1.5
Capacity		Machine Screw: M4 - M8 mm Standard Bolt: M5 - M12 High Tensile Bolt: M5 - M10 Coarse thread (in length): 22 - 90 mm		
Hex Shank		6.35 mm		
No Load Speed (RPM)		0 - 2,600		
Impacts Per Minute (IPM)		0 - 3,500		
Max Fastening Torque		110 N-m (970 in.lbs.)		
Vibration Level		8.0 m/s ²		
Sound Pressure Level		94 dB(A)		
Sound Power Level		105 dB(A)		
Max Output		120 W		
Dimensions		153x66x204 mm		
(L x W x H)		(6"x2-5/8"x8-1/8")		
Net weight		1.0 - 1.2 kg (2.3 - 2.6 lbs)		

Belt clip, Phillips bit

CLX201 - Cordless Combo Kit

DF331D + TD110D, 2 Batteries, Charger, Tool Bag

CLX201AX6 - Rs. 28,000



12V MAX

Cordless Driver Combo Kit

TW140D - Cordless Impact Wrench

12V max CXT Li-Ion Cordless 3/8" (9.5 mm) 140 N-m (1,240 in.lbs.) (3/8" Square) Impact Wrench

TW140DWAE - Rs. 14,500
TW140DWYEX - Rs. 00,000
TW140DZ - Rs. 5,500



Li-ion	Ah	4.0	2.0	1.5
Fastening Capacities		Standard Bolt: M8 - M16 (5/16" - 5/8") High Tensile Bolt: M6 - M12 (1/4" - 1/2")		
Square Drive		9.5 mm (3/8")		
No Load Speed (RPM)		0 - 2,600		
Impacts Per Minute (IPM)		0 - 3,200		
Max Fastening Torque		140 N-m (1,240 in.lbs.)		
Max Output		125 W		
Vibration Level		Impact tightening of fasteners of the maximum capacity of the tool: 8.0 m/s ²		
Sound Pressure Level		88 dB(A)		
Sound Power Level		99 dB(A)		
Dimensions		w/ BL1041B: 161x66x224 mm		
(L x W x H)		(6-3/8"x2-5/8"x8-7/8")		
Net weight		1 - 1.2 kg (2.3 - 2.7 lbs.)		

Belt Clip

TL064D - Cordless Angle Impact Driver

12V max CXT Li-Ion Cordless 60 N-m (530 in.lbs.) (1/4" Hex) Angle Impact Driver

TL064DWYE - Rs. 30,000



Li-ion	Ah	4.0	2.0	1.5
Capacity		Machine Screw: M4 - M8 Standard Bolt: M4 - M12 High Tensile Bolt: M4 - M8 Coarse thread (in length): 22 - 75 mm		
Hex Shank		6.35 mm (1/4")		
No Load Speed (RPM)		0 - 2,000		
Impacts Per Minute (IPM)		0 - 3,000		
Max Fastening Torque		60 N-m (530 in.lbs.)		
Vibration Level		Impact tightening of fasteners of the maximum capacity of the tool: 15.0 m/s ²		
Sound Pressure Level		91 dB(A)		
Sound Power Level		102 dB(A)		
Dimensions		361x66x86 mm		
(L x W x H)		(14-1/4"x2-5/8"x3-3/8")		
Net weight		1.2 - 1.6 kg (2.7 - 3.6 lbs)		

Phillips Bit, Belt Clip

TL065D - Cordless Angle Impact Wrench

12V max CXT Li-Ion Cordless 60 N-m (530 in.lbs.) (3/8" Square) Angle Impact Wrench

TL065DWYE - Rs. 30,000



Li-ion	Ah	4.0	2.0	1.5
Capacity		Standard Bolt: M4 - M12 High Tensile Bolt: M4 - M8		
Square Drive		9.5 mm (3/8")		
No Load Speed (RPM)		0 - 2,000		
Impacts Per Minute (IPM)		0 - 3,000		
Max Fastening Torque		60 N-m (530 in.lbs.)		
Vibration Level		Impact tightening of fasteners of the maximum capacity of the tool: 18.0 m/s ²		
Sound Pressure Level		90 dB(A)		
Sound Power Level		101 dB(A)		
Dimensions		361x66x86 mm		
(L x W x H)		(14-1/4"x2-5/8"x3-3/8")		
Net weight		1.2 - 1.6 kg (2.7 - 3.6 lbs)		

Belt Clip

HR140D - Cordless Rotary Hammer

12V max CXT Li-Ion Cordless 14 mm (9/16") Rotary Hammer, SDS-PLUS Bits

HR140DWYE1 - Rs. 45,000
HR140DWYJ - Rs. 20,000
HR140DZ



Li-ion	Ah	4.0	2.0	1.5
Impact Energy		EPTA-Procedure 05/2009: 1.0 J Our experimental conditions: 0.9 J		
Capacity		Concrete: 14 mm / Steel: 10 mm / Wood: 13 mm		
Impacts Per Minute (IPM)		0 - 4,900		
No Load Speed (RPM)		0 - 850		
Vibration Level		Hammer Drilling Into Concrete: 6.5 m/s ² Drilling Into Metal: 3.0 m/s ² or less		
Sound Pressure Level		84 dB(A)		
Sound Power Level		95 dB(A)		
Dimensions		w/ BL1016/BL1021B: 246x74x179 mm (9-11/16"x2-15/16"x7") w/ BL1041B: 246x74x198 mm (9-11/16"x2-15/16"x7-3/4")		
(L x W x H)				
Net weight		1.9 - 2.6 kg (4.3 - 5.6 lbs)		

Side Grip, Depth Gauge, Dust Cup (country-specific)

CC301D - Cordless Cutter

12V max CXT Li-Ion Cordless 85 mm (3-3/8") Cutter, Wet Type

CC301DWAE - Rs. 22,500
CC301DZ - Rs. 12,000



Li-ion	Ah	4.0	2.0	1.5
Blade Diameter		85 mm (3-3/8")		
Max Cutting Capacity		90°: 25.5 mm (1") 45°: 16.5 mm (5/8")		
No Load Speed (RPM)		1,600		
Tank capacity		Water: 0.5 L		
Vibration Level		Concrete Cutting: 2.5 m/s ²		
Sound Pressure Level		84 dB(A)		
Sound Power Level		95 dB(A)		
Dimensions		313x170x125 mm		
(L x W x H)		(12-3/8"x6-11/16"x4-7/8")		
Net weight		1.9 kg (4.1 lbs)		

Battery cover, Diamond wheel, Hex Wrench, Water supply tank assembly



Cordless Multi Cutter CP100D



Handy size for easy maneuverability in various applications for home and professional use

Cardboard



Cardboard Carton (t=5mm, L=500mm)

1,200 Cuts
with BL1016 / per charge

Carpet



Felt



Leather



Vinyl sheet



Rubber mat



CP100D - Cordless Multi Cutter

Li-Ion Ah 4.0 2.0 1.5



12V max CXT Li-Ion Cordless Multi Cutter

- Large Work Amount on a Single Battery Charge
- High power satisfies even professional needs such as carpet contractors
- Cuts thin and thick material up to 6 mm such as cardboard, carpet, fabrics, leather, CD, DVD & Blu-ray
- Handy size for easy maneuverability in various applications for home and professional use
- Auto self-sharpening function maintains sharp performance

Without Battery, Blade

Max Cutting Capacity	6 mm (1/4")
No Load Speed (RPM)	300
Vibration Level	Cutting Cardboard: 2.5 m/s ² or less
Sound Pressure Level	70 dB(A) or less
Dimensions (L x W x H)	with BL1016/BL1021B: 272x66x120 mm (10-3/4"x2-5/8"x4-3/4") with BL1041B: 291x66x121 mm (11-1/2"x2-5/8"x4-3/4")
Net weight	0.72 - 0.88 kg (1.6 - 1.9 lbs)



CP100DWA - Rs. 13,000
CP100DZ - Rs. 5,000



TM30D - Cordless Multi Tool

12V max CXT Li-Ion Cordless Multi Tool

TM30DSAE - Rs. 19,500
TM30DZ - Rs. 9,000



Li-ion	Ah	4.0	2.0	1.5
Oscillations Per Minute (OPM)		6,000 - 20,000		
Oscillation Angle		Left / Right / Total: 1.6° / 1.6° / 3.2°		
Vibration Level		Sanding: 2.5 m/s ² or less Plunge Saw Blade: 10.5 m/s ² Segmental Saw Blade: 5.5 m/s ² Scraping: 9.0 m/s ² Sanding: 75 dB(A)		
Sound Pressure Level		Plunge Saw Blade: 82 dB(A) Segmental Saw Blade: 81 dB(A) Scraping: 81 dB(A)		
Sound Power Level		Plunge Saw Blade: 93 dB(A) Segmental Saw Blade: 92 dB(A) Scraping: 92 dB(A)		
Max Output		170 W		
Net weight		1.1 - 1.3 kg (2.3 - 2.9 lbs)		



Hex wrench

JV103D - Cordless Jig Saw

12V max CXT BL Brushless Cordless Top Handle Jig Saw, 3 Orbital Settings Plus Straight Cutting, LED Light

JV103DWYJ - Rs. 23,000
JV103DZ - Rs. 14,000



Li-ion	Ah	4.0	2.0	1.5
Max Cutting Capacity at 90°		Wood / Aluminum / Mild Steel: 90 / 20 / 10 mm (3-1/2" / 13/16" / 3/8")		
Length of Stroke		23 mm (7/8")		
Strokes Per Minute (SPM)		800 - 3,000		
Vibration Level		Cutting Boards: 8.5 m/s ² Cutting Sheet Metal: 6.0 m/s ²		
Sound Pressure Level		85 dB(A)		
Sound Power Level		96 dB(A)		
Dimensions (L x W x H)		237x76x206 mm (9-3/8"x3"x8-1/8")		
Net weight		1.9 - 2.0 kg (4.1 - 4.4 lbs)		



Jig Saw Blade, Hex Wrench, Cover Plate (country-specific), Dust Nozzle, Dust Cover

JV101D - Cordless Jig Saw

Compact and lightweight body optimum for light duty cutting

JV101DWYE - Rs. 17,000



Li-ion	Ah	4.0	2.0	1.5
Max Cutting Capacity at 90°		Wood / Aluminum / Mild Steel: 65 / 4 / 2 mm (2-9/16" / 5/32" / 1/16")		
Length of Stroke		18 mm (11/16")		
Strokes Per Minute (SPM)		0 - 2,900		
Vibration Level		Cutting Boards: 7.0 m/s ² Cutting Sheet Metal: 5.5 m/s ²		
Sound Pressure Level		80 dB(A)		
Sound Power Level		91 dB(A)		
Dimensions (L x W x H)		232x76x196 mm (9-1/8"x3"x7-3/4")		
Net weight		1.8 - 1.9 kg (3.9 - 4.3 lbs)		



Jig saw blade (No. B-10), Hex wrench

JR103D - Cordless Recipro Saw

12V max CXT Li-Ion Cordless Recipro Saw

JR103DWAE - Rs. 19,500
JR103DWYE - Rs. 18,000
JR103DZ - Rs. 9,000



Li-ion	Ah	4.0	2.0	1.5
Length of Stroke		13 mm (1/2")		
Strokes Per Minute (SPM)		0 - 3,300		
Capacity		Pipe / Wood: 50 / 50 mm (2" / 2")		
Vibration Level		Cutting Boards: 8.0 m/s ² Cutting Wooden Beams: 8.0 m/s ²		
Sound Pressure Level		78 dB(A)		
Max Output		210 W		
Dimensions (L x W x H)		376x66x186 mm (14-3/4"x3-5/8"x7-3/8")		
Net weight		1.3 - 1.5 kg (2.9 - 3.2 lbs)		



Battery cover, Hex wrench, Recipro saw blades

SD100D - Cordless Drywall Saw

12V max CXT Li-Ion Cordless Drywall Saw

SD100DWYJ - Rs. 34,000
SD100DZ - Rs. 25,000



Li-ion	Ah	4.0	2.0	1.5
Strokes Per Minute (SPM)		0 - 6,000		
Length of Stroke		6 mm (1/4")		
Capacity		Drywall: 30 mm (1-3/16") Wood: 15 mm (9/16")		
Vibration Level		Cutting Drywall (thickness 30mm): 3.0 m/s ² Cutting Chip Board (thickness 15mm): 5.5 m/s ²		
Sound Pressure Level		77 dB(A)		
Dimensions (L x W x H)		239x79x266 mm (9-3/8"x3-1/8"x10-1/2")		
Net weight		1.4 - 1.6 kg (3.2 - 3.5 lbs)		



Blade, Blade Cover, Base Cover, Hex Wrench

ST113D - Cordless Stapler

12V CXT Li-Ion Cordless 10 mm (3/8") RT Stapler

ST113DWYJ - Rs. 39,000
ST113DZ - Rs. 30,000



Li-ion	Ah	4.0	2.0	1.5
Staple		Width: 10 mm (3/8") Length: 7, 10 mm (9/32", 3/8") Gauge: 0.5 x 0.7 mm		
Magazine Capacity		150 (max 160)		
Vibration Level		2.5 m/s ² or less		
Sound Pressure Level		75 dB(A)		
Dimensions (L x W x H)		211x81x159 mm (8-5/16"x3-1/16"x6-1/4")		
Net weight		1.3 kg (2.9 lbs)		



Safety Goggles, Belt Clip

PT354D - Cordless Pin Nailer

12V max CXT Li-Ion Cordless 23 GA 35 mm (1-3/8") Pin Nailer

PT354DWYJ - Rs. 42,000
PT354DZ - Rs. 30,000



Li-ion	Ah	4.0	2.0	1.5
Capacity		Length: 15, 18, 25, 30, 35 mm (5/8", 11/16", 1", 1-3/16", 1-3/8") Dia: 0.6 mm (1/32") Gauge: 23 Ga		
Magazine Capacity		120		
Vibration Level		2.5 m/s ² or less		
Sound Pressure Level		76 dB(A)		
Dimensions (L x W x H)		231x66x226 mm (9-1/8"x2-5/8"x8-7/8")		
Net weight		1.8 - 2.0 kg (4.0 - 4.4 lbs)		



Nose Adapter, Safety Goggles, Belt Clip, Hex Wrench

CG100D - Cordless Caulking Gun

12V max CXT Li-Ion Cordless Caulking Gun

CG100DWAEA - Rs. 30,500
CG100DZA - Rs. 19,000



Li-ion	Ah	4.0	2.0	1.5
Max Dispensing Force		5,000 N (1,100 lbs)		
No load speed		0 - 28 mm/sec. (0 - 66 in/min.)		
Holder Size		300, 600, 800 mL		
Sound Pressure Level		70 dB(A) or less		
Vibration Level		Operation w/o Load: 2.5 m/s ² or less		
Dimensions (L x W x H)		404x108x259 mm (15-7/8"x4-1/4"x10-1/4")		
Net weight		1.9 - 2.6 kg (4.2 - 5.8 lbs)		



Holder, Holder Joint, Piston, Rubber Ring, Nozzle



CL106FD - Cordless Cleaner

High power & New design, with LED light **CL106FDWY - Rs. 13,000**
Disposal type: Capsule



Li-ion	Ah	4.0	2.0	1.5
Capacity		600 mL		
Continuous Use (min.)		with BL1041B: 42		
Max Air Flow		1.3 m ³ /min		
Max Sealed Suction (water column)		3.1 kPa (316 mmH ₂ O)		
Dimensions (L x W x H)		958x100x150 mm		
Net weight		1.0 kg (2.2 lbs.)		

Battery cover, Charger, T-Nozzle assembly, Pipe, Sash nozzle, Sash nozzle holder, Dust bag

CL107FD - Cordless Cleaner

High power & New design, with LED light **CL107FDWY - Rs. 14,000**
Disposal type: Dust bag



Li-ion	Ah	4.0	2.0	1.5
Capacity		Dust Bag: 500 mL		
		Paper Pack: 330 mL		
Max air flow		Max: 20 / High: 24 / Normal: 50		
Continuous use (minutes)		1.4 m ³ /min		
Max sealed suction (water column)		5.0 kPa (510 mmH ₂ O)		
Dimensions (L x W x H)		960x112x150 mm		
Net weight		(37-3/4"x4-3/8"x5-7/8") 1.1 kg (2.5 lbs.)		

Battery cover, T-Nozzle assembly, Pipe, Sash nozzle, Sash nozzle holder, Dust bag

CF100D - Cordless Fan

12V max CXT Li-Ion Cordless 180 mm (7-1/8") Fan **CF100DZ - Rs. 6,000**



Li-ion	Ah	4.0	2.0	1.5
Continuous Use (min.)		w/ BL1041B Low / Medium / High: 630 / 380 / 275		
		w/ BL1021B Low / Medium / High: 315 / 190 / 135		
		w/ BL1016 Low / Medium / High: 240 / 145 / 105		
Dimensions (L x W x H)		w/ BL1041B: 168x260x252 mm (6-5/8"x10-1/4"x9-7/8")		
		w/ BL1016/BL1021B: 149x260x252 mm (5-7/8"x10-1/4"x9-7/8")		
		w/o Battery: 148x260x252 mm (5-7/8"x10-1/4"x9-7/8")		
Net weight		1.2 - 1.4 kg (2.7 - 3.1 lbs)		

AC Adaptor

CF101D - Cordless Fan

12V max CXT Li-Ion Cordless 180 mm (7-1/8") Automatic Swing Fan **CF101DZ - Rs. 7,000**



Li-ion	Ah	4.0	2.0	1.5
Continuous Use (min.)		w/ BL1041B Low / Medium / High: 630 / 380 / 275		
		w/ BL1021B Low / Medium / High: 315 / 190 / 135		
		w/ BL1016 Low / Medium / High: 240 / 145 / 105		
Air Flow		High / Medium / Low: 4.6 / 3.8 / 3.0 L/min		
Dimensions (L x W x H)		185x260x284 mm (7-1/4"x10-1/4"x11-1/8")		
Net weight		1.3 - 1.7 kg (2.8 - 3.8 lbs.)		

new

DCM501 - Cordless Coffee Maker

12V max / 14.4V / 18V CXT LXT Li-Ion Cordless Coffee Maker **DCM501Z - Rs. 11,000**



Li-ion	Ah	4.0	2.0	1.5
Water Tank Capacity		240 mL		
Compatible Cafe Pod Type		60 mm		
Dimensions (L x W x H)		w/ BL1041B: 243x185x218 mm (9-9/16"x7-5/16"x8-9/16")		
		w/ BL1830B / BL1840B / BL1850B / BL1860B: 243x187x218 mm (9-9/16"x7-3/8"x8-9/16")		
Net weight		1.9 - 2.2 kg (4.1 - 4.8 lbs.)		

Mug, Measuring Spoon

UR100D - Cordless Grass Trimmer

12V max CXT Li-Ion Cordless Grass Trimmer **UR100DWAE - Rs. 22,500**
UR100DWAEX - Rs. 22,500
UR100DZ - Rs. 12,000
UR100DZX - Rs. 12,000



Li-ion	Ah	2.6	2.2	1.5
Cutting Width		Nylon Cutting Head: 260 mm (10") Plastic Blade: 230 mm (9")		
No Load Speed (RPM)		10,000		
Spindle Size		M8 x 1.25 RH		
Max Output		130 W		
Dimensions (L x W x H)		835 - 1,185x267x210 - 315 mm (32-7/8 - 46-3/4"x10-1/2"x8-1/4 - 12-3/8")		
Net weight		1.9 - 2.1 kg (4.3 - 4.6 lbs.)		

Safety Goggles, Shoulder Belt, Hex Wrench

UH201D - Cordless Hedge Trimmer

12V max CXT Li-Ion Cordless 20 cm (7-7/8") Hedge Trimmer **UH201DWY - Rs. 12,000**
UH201DZ - Rs. 7000



Li-ion	Ah	4.0	2.0	1.5
Blade Length		200 mm (7-7/8")		
Tooth Spacing		26 mm (1")		
Strokes Per Minute (SPM)		2,500		
Continuous Use (min.)		w/ BL1041B / BL1021B / BL1016: 90 / 45 / 35 min		
Sound Pressure Level		74 dB(A)		
Vibration Level		2.5 m/s ² or less		
Dimensions (L x W x H)		504x120x131 mm (19-7/8"x4-3/4"x5-1/8")		
Net weight		1.3 - 1.5 kg (2.8 - 3.3 lbs)		

Blade Cover, Chip Receiver

UM600D - Cordless Grass Shear

12V CXT Li-Ion Cordless 16 cm (6-5/16") Grass Shear **UM600DWYE - Rs. 17,000**
UM600DZ - Rs. 8000



Li-ion	Ah	4.0	2.0	1.5
Cutting Width		160 mm (6-5/16")		
Strokes Per Minute (SPM)		1,250		
Dimensions (L x W x H)		301x177x131 mm		
Net weight		1.4 kg (3.1 lbs.)		

Base Frame, Blade Cover



Cordless Fan Jacket Series

DFJ210 / DFJ211 / DFJ310 / DFJ311 / DFJ410 / DFJ411
DFJ212 / DFJ213 / DFJ214 / DFV210 /



Stay cool in hot harsh job sites



Polyester
Water repellent

Stand-up collar

DFJ210

With hood

DFJ211



Cotton
Water absorbency

Stand-up collar

DFJ310

With hood

DFJ311



Titanium-coated polyester
UV and IR reflection

Stand-up collar

DFJ410

With hood

DFJ411



Polyester
High-repelle

Stand-up collar

Casual type

DFJ212



Features



Mesh pocket for ice pack

■ DFJ210 / DFJ211
■ DFJ310 / DFJ311
■ DFJ410 / DFJ411



Hood with mesh ear design

■ DFJ210
■ DFJ410 ■ DFJ310



Stowaway hood

■ DFJ212



Pen pocket

■ DFJ210 / DFJ211
■ DFJ310 / DFJ311
■ DFJ410 / DFJ411
■ DFJ213



Arm pocket

■ DFJ212
■ DFJ214



Loops for attaching safety pin

■ DFJ210 / DFJ211
■ DFJ310 / DFJ311
■ DFJ410 / DFJ411



Foldable sleeves

■ DFJ310 / DFJ311
■ DFJ410 / DFJ411



Shoulder pocket

■ DFJ410

Comparison of body temperature rise during work

Skin temperature after a 10-minute work under temperature of 35°C and humidity of 60%

Never use the fan jacket where temperature reaches more than 50°C (122°F). Otherwise it may cause burns on your skin. Also avoid using in high humidity.

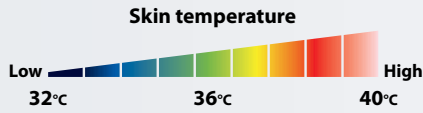

Circulate air throughout at the entire jacket

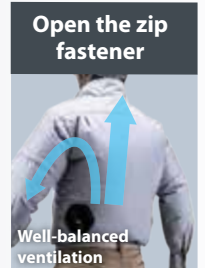
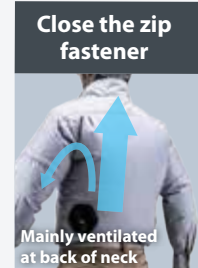
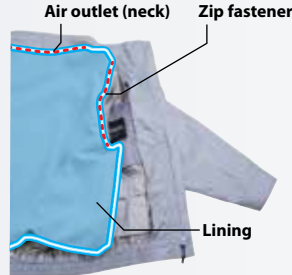

DFJ212 DFJ213 DFJ214 DFV210

DFJ210 / DFJ211 DFJ310 / DFJ311 DFJ410 / DFJ411

Use of high performance fabric to fit the various scenes



Moisture-permeable, waterproof fabric
 water scarcely permeate even the water-resistant pressure of 1,000mm

DFJ212 DFV210



Stretchable fabric
 lightweight, stretchable, windproof comfortable to wear

DFJ213



Water-repellent, antistatic fabric
 water-repellent and breathability make reduced in stuffy feeling

DFJ214



High-repellency fabric
 with stowaway hood

Polyester
Stretchable fabric

Stand-up collar Working wear type
 DFJ213



Polyester
Water repellency, antistatic fabric

Stand-up collar High-visibility type
 DFJ214



Polyester
High-repellency fabric

Stand-up collar Vest type
 DFV210



Shoulder pads
 / DFJ411



Insert supporting slider
 DFJ212 DFV210



Velcro tabs for cuff adjustment
 DFJ212



Drawcord on hem for adjustable fit
 DFJ212 DFV210



Zip fastener with quick release function
 DFJ213 DFJ214



Snap button and rubber shirring for hem adjustment
 DFJ213 DFJ214



Antistatic
 DFJ214



Retroreflective material
 DFJ214



DFJ202D - Cordless Fan Jacket

18V / 14.4V / 12V max LXT CXT Li-Ion Fan Jacket for General Work, Hood

DFJ202DZM - Rs. 15,000



Li-ion	Ah	4.0	2.0	1.5	
Run Time (hrs)	w/ BL1860B	Low / Medium / High:	34 / 25 / 14		
Air Flow Settings	Turbo / High / Medium / Low				
Air Flow	Turbo / High / Medium / Low: 1.4 / 1.2 / 1.0 / 0.8 m ³ /min				
Size	S / M / L / XL / 2XL / 3XL				
Pockets	5				
Net weight	710 g (1.6 lbs)				

Fan Hook

DFJ203D - Cordless Fan Jacket

18V / 14.4V / 12V max LXT CXT Li-Ion Fan Jacket for General Work, Hood

DFJ203DZM - Rs. 16,000



Li-ion	Ah	4.0	2.0	1.5	
Run Time (hrs)	w/ BL1860B	Low / Medium / High:	34 / 25 / 14		
Air Flow Settings	Turbo / High / Medium / Low				
Air Flow	Turbo / High / Medium / Low: 1.4 / 1.2 / 1.0 / 0.8 m ³ /min				
Size	S / M / L / XL / 2XL / 3XL				
Pockets	5				
Net weight	1.5 - 1.9 kg (3.3 - 4.1 lbs)				

Fan Hook

DFJ210 - Cordless Fan Jacket

18V / 14.4V / 12V max LXT CXT BL Fan Jacket for General Work, Stand-Up Collar

DFJ210Z2XL - Rs. 15,000

DFJ210ZL - Rs. 15,000

DFJ210ZXL - Rs. 15,000



new



Li-ion	Ah	5.0	4.0	3.0	2.0	1.5
Run Time (hrs)	w/ BL1860B	Low / Medium / High:	33 / 24.5 / 13.5			
Air Flow Settings	Turbo / High / Medium / Low					
Air Flow	Turbo / High / Medium / Low: 2.2 / 2.1 / 1.7 / 1.5 m ³ /min					
Size	S / M / L / XL / 2XL / 3XL					
Pockets	5					
Net weight	0.39 kg (0.9 lbs.)					



DFJ211 - Cordless Fan Jacket

18V / 14.4V / 12V max LXT CXT BL Fan Jacket for General Work, Hood

DFJ211Z2XL - Rs. 16,000

DFJ211ZL - Rs. 16,000

DFJ211ZXL - Rs. 16,000



new



Li-ion	Ah	5.0	4.0	3.0	2.0	1.5
Run Time (hrs)	w/ BL1860B	Low / Medium / High:	33 / 24.5 / 13.5			
Air Flow Settings	Turbo / High / Medium / Low					
Air Flow	Turbo / High / Medium / Low: 2.2 / 2.1 / 1.7 / 1.5 m ³ /min					
Size	S / M / L / XL / 2XL / 3XL					
Pockets	5					
Net weight	0.41 kg (0.9 lbs.)					



DFJ214 - Cordless Fan Jacket

18V / 14.4V / 12V max LXT CXT BL Fan Jacket, High-Visibility Type, Stand-Up Collar

DFJ214ZM - Rs. 25,000

DFJ214ZL - Rs. 25,000

DFJ214ZXL - Rs. 25,000



new



Li-ion	Ah	5.0	4.0	3.0	2.0	1.5
Run Time (hrs)	w/ BL1860B	Low / Medium / High:	33 / 24.5 / 13.5			
Air Flow Settings	Turbo / High / Medium / Low					
Air Flow	Turbo / High / Medium / Low: 2.2 / 2.1 / 1.7 / 1.5 m ³ /min					
Size	S / M / L / XL / 2XL / 3XL					
Pockets	5					
Net weight	0.54 kg (1.2 lbs.)					



DFJ212 - Cordless Fan Jacket

18V / 14.4V / 12V max LXT CXT BL Fan Jacket, Casual Type, Stand-Up Collar w/ Stowaway Hood

DFJ212ZM - Rs. 22,000

DFJ212ZL - Rs. 22,000

DFJ212ZXL - Rs. 22,000



new



Li-ion	Ah	5.0	4.0	3.0	2.0	1.5
Run Time (hrs)	w/ BL1860B	Low / Medium / High:	33 / 24.5 / 13.5			
Air Flow Settings	Turbo / High / Medium / Low					
Air Flow	Turbo / High / Medium / Low: 2.2 / 2.1 / 1.7 / 1.5 m ³ /min					
Size	S / M / L / XL / 2XL / 3XL					
Pockets	5					
Net weight	0.43 kg (0.9 lbs.)					



DFJ213 - Cordless Fan Jacket

18V / 14.4V / 12V max LXT CXT BL Fan Jacket, Working Wear Type, Stand-Up Collar

DFJ213ZM - Rs. 21,000

DFJ213ZL - Rs. 21,000

DFJ213ZXL - Rs. 21,000



new



Li-ion	Ah	5.0	4.0	3.0	2.0	1.5
Run Time (hrs)	w/ BL1860B	Low / Medium / High:	33 / 24.5 / 13.5			
Air Flow Settings	Turbo / High / Medium / Low					
Air Flow	Turbo / High / Medium / Low: 2.2 / 2.1 / 1.7 / 1.5 m ³ /min					
Size	S / M / L / XL / 2XL / 3XL					
Pockets	5					
Net weight	0.54 kg (1.2 lbs.)					



DFV210 - Cordless Fan Vest

18V / 14.4V / 12V max LXT CXT BL Fan Vest, Stand-Up Collar

DFV210ZM - Rs. 20,000

DFV210ZL - Rs. 20,000

DFV210ZXL - Rs. 20,000



new



Li-ion	Ah	5.0	4.0	3.0	2.0	1.5
Run Time (hrs)	w/ BL1860B	Low / Medium / High:	33 / 24.5 / 13.5			
Air Flow Settings	Turbo / High / Medium / Low					
Air Flow	Turbo / High / Medium / Low: 2.2 / 2.1 / 1.7 / 1.5 m ³ /min					
Size	S / M / L / XL / 2XL / 3XL					
Pockets	3					
Net weight	0.38 kg (0.8 lbs.)					





ML106 - Cordless LED Flashlight

12V max CXT Li-Ion Cordless LED Flashlight, 190 Lumens **ML106 - Rs. 5,200**



Li-ion	Ah	4.0	2.0	1.5
Run Time (hrs)		Up to: 12		
Luminous flux		190 lm		
Illuminance		at 1m from the light source 170 - 4,500 lx		
Dimensions (L x W x H)		with BL1016/BL1021B: 271x66x93 mm (10-5/8"x2-5/8"x3-5/8") with BL1041B: 290x66x93 mm (11-3/8"x2-5/8"x3-5/8")		
Net weight		0.61 - 0.78 kg (1.3 - 1.7 lbs)		

Strap Hook

ML105 - Cordless LED Flashlight

12V max CXT Li-Ion LED Flashlight, 190 Lumens **ML105 - Rs. 4,350**



Li-ion	Ah	4.0	2.0	1.5
Run Time (hrs)		Up to: 14		
Luminous flux		190 lm		
Illuminance		at 1m from the light source 5,500 lx		
Dimensions (L x W x H)		with BL1016/BL1021B: 249x66x93 mm (9-3/4"x2-5/8"x3-5/8") with BL1041B: 268x66x93 mm (10-1/2"x2-5/8"x3-5/8")		
Net weight		0.53 - 0.70 kg (1.2 - 1.5 lbs)		

Strap Hook

ML104 - Cordless LED Flashlight

12V max CXT Li-Ion 21 LED Flashlight, 710 Lumens **ML104 - Rs. 7,800**

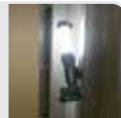

Li-ion	Ah	4.0	2.0	1.5
Run Time (hrs)		Up to: 19		
Main light (on bar side)		Luminous flux (Full brightness): 710 lm Illuminance (Full brightness): 340 lx		
Sub light (on top side)		Luminous flux: 130 lm Illuminance: 1,900 lx		
Dimensions (L x W x H)		414x66x132 mm (16-1/4"x2-5/8"x5-3/16")		
Net weight		0.61 - 0.78 kg (1.4 - 1.7 lbs)		

ML103 - Cordless LED Flashlight

12V max CXT Li-Ion LED Flashlight, 100 Lumens **ML103 - Rs. 2,270**



Li-ion	Ah	4.0	2.0	1.5
Run Time (hrs)		Up to: 28		
Dimensions (L x W x H)		without Battery: 77x54x28 mm (3x2-1/8x1-1/8") with BL1016/BL1021B: 87x64x54 mm (3-7/16"x2-1/2"x2-1/8") with BL1041B: 87x64x73 mm (3-7/16"x2-1/2"x2-7/8")		
Net weight		0.27 - 0.43 kg (0.6 - 1.0 lbs)		



10.8 Lithium-ion



TW100D - Cordless Impact Wrench

10.8V Li-Ion Cordless 3/8" (9.5 mm)
110 N-m (1,000 in.lbs.) Impact Wrench

TW100DWE - Rs. 16,000



Li-ion		Ah	1.3			
Fastening Capacities	Standard Bolt:	M8 - M12 (5/16" - 1/2")				
	High Tensile Bolt:	M6 - M10 (1/4" - 3/8")				
Square Drive		9.5 mm (3/8")				
No Load Speed (RPM)		0 - 2,300				
Impacts Per Minute (IPM)		0 - 3,000				
Max Fastening Torque		110 N-m (1,000 in.lbs.)				
Vibration Level		Impact tightening of fasteners of the maximum capacity of the tool:				
		8.0 m/s ²				
Sound Pressure Level		88 dB(A)				
Sound Power Level		99 dB(A)				
Dimensions (L x W x H)		163x54x178 mm (6-3/8"x2-1/8"x7")				
Net weight		0.95 kg (2.1 lbs)				



7.2V Lithium-ion



DF012D - Cordless Driver Drill

7.2V Li-Ion Cordless Two-Position 5 mm (3/16") 8 N-m (71 in.lbs.) Driver Drill

DF012DSE - Rs. 16,000



Li-ion		Ah	1.0			
Capacity	Steel:	5 mm (3/16")				
	Wood:	6 mm (1/4")				
No Load Speed (RPM)		High: 650				
		Low: 200				
Max Fastening Torque		Hard / Soft: 5.6 / 3.6 N-m (50 / 32 in.lbs.)				
Max lock torque		8.0 N-m (71 in.lbs.)				
Vibration Level		Drilling Into Metal: 2.5 m/s ² or less				
Sound Pressure Level		70 dB(A) or less				
Dimensions (L x W x H)	Pistol Style:	218x44x142 mm (8-5/8"x1-3/4"x5-5/8")				
Dimensions (L x W)	Straight Style:	273x44 mm (10-3/4"x1-3/4")				
Net weight		0.53 kg (1.2 lbs.)				

Phillips Bit

TD022D - Cordless Impact Driver

7.2V Li-Ion Cordless Two-Position 25 N-m (220 in.lbs.) Impact Driver

TD022DSE - Rs. 17,000



Li-ion		Ah	1.0			
Capacity	Machine Screw:	M3 - M8				
	Standard Bolt:	M3 - M8				
	High Tensile Bolt:	M3 - M6				
	Coarse thread (in length):	22 - 45 mm				
Hex Shank		6.35 mm (1/4")				
No Load Speed (RPM)		0 - 2,450				
Impacts Per Minute (IPM)		0 - 3,000				
Max Fastening Torque		25 N-m (220 in.lbs.)				
Vibration Level		Fastening Bolt: 7.0 m/s ²				
Sound Pressure Level		85 dB(A)				
Sound Power Level		96 dB(A)				
Dimensions (L x W x H)	Straight Style:	282x42x52 mm (11-1/8"x1-5/8"x2-1/16")				
	Pistol Style:	227x42x142 mm (8-15/16"x1-5/8"x5-5/8")				
Net weight		0.55 - 0.56 kg (1.2 lbs)				

Holster, Bit set

3.6V Lithium-ion

Built-in Battery

DF001D - In-Line Cordless Screwdriver

3.6V Li-Ion In-Line Cordless 6.0 N-m (53 in.lbs.)
Screwdriver, Built-In Battery

DF001DW - Rs. 6,000



Li-ion		Ah	5.0	4.0	3.0	1.5
Fastening Capacities	Wood Screw:	ø3.8 x 32 mm				
No Load Speed (RPM)		220				
Max Fastening Torque		Hard / Soft: 4.0 / 3.0 N-m (35 / 27 in.lbs.)				
Max lock torque		6.0 N-m (53 in.lbs.)				
Vibration Level		Screwdriving w/o Impact: 2.5 m/s ² or less				
		70 dB(A) or less				
Sound Pressure Level		70 dB(A) or less				
Charging Time (hours)		3 dB(A)				
Dimensions (L x W x H)	Straight Style:	287x47x51 mm (11-1/4"x1-7/8"x2")				
	Pistol Style:	205x47x51 mm (8-1/8"x1-7/8"x2")				
Net weight		0.36 kg (0.79 lbs)				

Bit set (81 pcs), AC Adaptor, USB Cable

Drilling / Fastening



DP2010 - High Speed Drill

6.5 mm (1/4") 370 W High Speed Variable Speed Reversing Drill

DP2010 - Rs. 5,100



Continuous rating Input	370W
Capacity	Steel : 6.5mm (1/4") Wood : 15mm (9/16")
No load speed (rpm)	0-4,200
Dimensions (L x W x H)	209x64x175mm (8-1/4"x2-1/2"x6-7/8")
Net weight	1.0kg (2.2lbs)
Power supply cord	2.0m (6.6ft)



Depth Gauge (for some countries only)

6412 - Drill

10 mm (3/8") 450 W Variable Speed Reversing Drill

6412 - Rs. 5,600



Continuous rating input	450W
Capacity	Steel : 10mm (3/8") Wood : 25mm (1")
No load speed (rpm)	0-3,400
Dimensions (L x W x H)	228x64x183mm (9"x2-1/2"x7-1/4")
Net weight	1.3kg (2.9lbs)
Power supply cord	2.0m (6.6ft)



Chuck Key

DP4010 - 2-Speed Drill

13 mm (1/2") 720 W Variable 2-Speed Reversing Drill

DP4010 - Rs. 11,400



Continuous rating Input	720W
Capacity	Steel Hi : 8mm (5/16") Steel Lo : 13mm (1/2") Wood Hi : 25mm (1") Wood Lo : 40mm (1-9/16")
No load speed (rpm)	Hi : 0 - 2,900 Lo : 0 - 1,200
Dimensions (L x W x H)	347x70x220mm (13-5/8"x2-3/4"x8-5/8")
Net Weight	2.3kg (5.0lbs)
Power supply cord	2.5m (8.2ft)



Depth Gauge, Side Grip, Chuck Key

DA3010F - Angle Drill

10 mm (3/8") 450 W Angle Drill with Keyed Chuck

DA3010F - Rs. 24,300

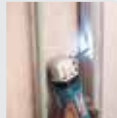

Continuous rating Input	450W
Capacity	Steel : 10mm (3/8") Wood : 25mm (1")
No load speed (rpm)	0-2,400
Overall length	270mm (10-5/8")
Net weight	1.6kg (3.5lbs)
Power supply cord	2.5m (8.2ft)



Chuck Key S10, Side Grip 36 Complete

DA4031 - Angle Drill

13 mm (1/2") 1,050 W Angle Drill with Keyed Chuck

DA4031 - Rs. 50,000



Continuous rating Input	1,050W
Capacity	Steel : 13mm (1/2") Wood (auger-bit) : 38mm (1-1/2") Wood (self-feed bit) : Hi : 65mm (2-9/16") Lo : 118mm (4-5/8")
No load speed (rpm)	Hi : 1,200 Lo : 300
Overall length	462mm (18-3/16")
Net Weight	6.3kg (13.9lbs)
Power supply cord	2.5m (8.2ft)



Chuck Key, Hex Wrench, Side Grip

DBM131 - Diamond Core Drill

132 mm (5-3/16") 1,700 W Diamond Core Drill, Wet & Dry

DBM131 - Rs. 87,700



Continuous rating input	1,700W
Capacity	Concrete (with Diamond core bit) : Hi : 70mm (2-3/4") Concrete (with Diamond core bit) : Lo : 132mm (5-3/16")
Tool holder	(Spindle) : M18
No load speed (rpm)	Hi : 0-2,300 Lo : 0-1,100
Net weight	6.3 kg (13.9 lbs)



Stand P-40082

DBM230 - Diamond Core Drill

230 mm (9") 2,500 W Diamond Core Drill

DBM230 - Rs. 1,55,000



Continuous rating input	2,500W
Capacity	Concrete (with Diamond core bit) : 230mm (9")
No load speed (rpm)	3rd : 1,700 2nd : 1,040 1st : 390
Net weight	37.5 kg (82.7 lbs)



Stand P-54190

TB131 - Drilling Machine

Compact drilling machine

TB131 - Rs. 24,000



new



Continuous rating input	250W
Capacity	Steel: 13 mm (1/2") Wood: 24 mm (1 5/16")
No Load Speed (RPM)	570, 890, 1,300, 1,900, 2,670 (50 Hz), 690, 1,070, 1,560, 2,280, 3,200 (60 Hz)
Net weight	20 kg (44.1 lbs.)
Power supply cord	1.75 m (5.7 ft)

Chuck Key, Wrench

HB500 - Magnetic Drill

50 mm (2") Magnetic Drill

HB500 - Rs. 1,30,000



new



Capacity	Steel: 50 mm (2")
Chuck capacity	16 mm (5/8")
No Load Speed (RPM)	350 / 650
Magnetic clamping force	Minimum 9,300N (950kg)
Dimensions (L x W x H)	290x150x450 mm (11-3/8"x5-7/8"x17-3/4")
Net weight	18.5 kg (40.8 lbs.)



Quick release arbor, Small oil cup assembly and clip, Safety guard, Polyester safety strap, Integral oil feed steady allen keys

TD0101 - Impact Driver

Compact design for perfect handling.

TD0101 - Rs. 7,400



411



Continuous rating Input	230W
Capacity	Machine screw: M4 - M8 (5/32" - 5/16") Standard bolt: M5 - M14 (3/16" - 9/16") High tensile bolt: M5 - M10 (3/16" - 3/8")
	Coarse thread (in length): 22 - 90mm (7/8" - 3-1/2")
Driving shank (Hex)	6.35mm (1/4")
Impacts per minute (ipm)	0-3,200
No load speed (rpm)	0-3,600
Max. fastening torque	100N.m (885in.lbs)
Dimensions (L x W x H)	184 x 67 x 192mm (7-1/4" x 2-5/8" x 7-9/16")
Net weight	0.99kg (2.2lbs)
Power supply cord	2.5m (8.2ft)



Phillips bit

FS2700 - Screwdriver

570 W 0-2,500 RPM 6 Stage Adjustable Torque
Screwdriver with LED Light

FS2700 - Rs. 15,000



419



Continuous rating input	570W
Capacity	Self-Drilling Screw: 6 mm (1/4") Machine Screw: 8 mm (5/16") Wood Screw: 6.2 mm (1/4")
Driving Shank (Hex)	6.35 mm (1/4")
No Load Speed (RPM)	0 - 2,500
Vibration Level	Screwdriving without Impact: 2.5 m/s ² or less
Sound Pressure Level	83 dB(A)
Sound Power Level	94 dB(A)
Dimensions (L x W x H)	301x70x207 mm (11-7/8"x2-3/4"x8-1/8")
Net weight	1.8 kg (4 lbs)
Power supply cord	2.5 m (8.2 ft.)



TW0200 - Impact Wrench

1/2" (12.7 mm) 200 N-m (150 ft.lbs.)
Impact Wrench

TW0200 - Rs. 25,000



411



Continuous rating input	380W
Fastening Capacities	Standard Bolt: M10 - M16 High Tensile Bolt: M10 - M12
Square Drive	12.7 mm
No Load Speed (RPM)	0 - 2,200
Impacts Per Minute (IPM)	0 - 2,200
Max Fastening Torque	200 N-m (150 ft.lbs.)
Vibration Level	Impact tightening of fasteners of the maximum capacity of the tool: 8.5 m/s ²
Sound Pressure Level	93 dB(A)
Sound Power Level	104 dB(A)
Dimensions (L x W x H)	251x72x220 mm (9-7/8"x2-13/16"x8-5/8")
Net weight	2.1 kg (4.7 lbs)
Power supply cord	2.5 m (8.2 ft)



Socket (3pcs.), Hook

TW0350 - Impact Wrench

Incredibly high torque of 350 N.M
(260ft. lbs.)

TW0350 - Rs. 28,000



411



Continuous rating Input	400W
Capacity	Standard bolt: M12 - M22 (1/2" - 7/8") High tensile bolt: M12 - M16 (1/2" - 5/8") Square drive: 12.7mm (1/2")
Impacts per minute (ipm)	2,000
No load speed (rpm)	2,000
Max. fastening torque	350N.m (260ft.lbs)
Overall length	282mm (11-1/8")
Net weight	3.0kg (6.6lbs)
Power supply cord	2.5m (8.2ft)



Socket

6906 - Impact Wrench

Powerful torque of 588 N.m (441ft. lbs)
for super-duty applications.

6906 - Rs. 54,000

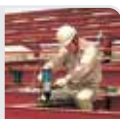

100



Continuous rating input	850W
Capacity	Standard Bolt: M16 - M22 High Tensile Bolt: M16 - M20
Square Drive	19 mm
No Load Speed (RPM)	1,700
Impacts Per Minute (IPM)	1,600
Max Fastening Torque	588 N-m (441 ft.lbs.)
Vibration Level	Impact tightening of fasteners of the maximum capacity of the tool: 16.5 m/s ²
Sound Pressure Level	98 dB(A)
Sound Power Level	109 dB(A)
Overall Length	327 mm (12-7/8")
Net weight	5.6 kg (12.2 lbs)
Power supply cord	2.5 m (8.2 ft)



Side Grip, Socket



TW1000 - Impact Wrench

Robust high torque Impact Wrench for heavy-duty application (1,000 N.m [738 ft. lbs]).

TW1000 - Rs. 80,000



153



Continuous rating input	1,200W
Fastening Capacities	Standard Bolt: M24 - M30 High Tensile Bolt: M22 - M24
Square Drive	25.4 mm
No Load Speed (RPM)	1,400
Impacts Per Minute (IPM)	1,500
Max Fastening Torque	1,000 N.m (738 ft.lbs.)
Vibration Level	Impact tightening of fasteners of the maximum capacity of the tool: 17.5 m/s ²
Sound Pressure Level	103 dB(A)
Sound Power Level	114 dB(A)
Dimensions (L x W x H)	382x110x290 mm
Net weight	8.8 kg (19.4 lbs)
Power supply cord	2.5 m (8.2 ft)



Socket, Side Grip

6922NB - Shear Wrench

Anti-slipping mechanism: tool won't start until inner sleeve engages with bolt tip. **6922NB - Rs. 1,68,000**



411



Continuous rating input	1,330W
Capacity	Bolt: M16, M20, M22 (5/8", 3/4", 7/8")
No Load Speed (RPM)	18
Max Fastening Torque	804 N.m (593 ft.lbs.)
Dimensions (L x W x H)	249x84x252 mm (9-13/16"x3-5/16"x9-15/16")
Net weight	4.9 kg (10.8 lbs)
Power supply cord	2.5 m (8.2 ft)



Inner Sleeve (20-38, 22-39) 2, Outer Sleeve (20-37, 22-39) 2, (-) Screwdriver

Impact Drilling / Demolition

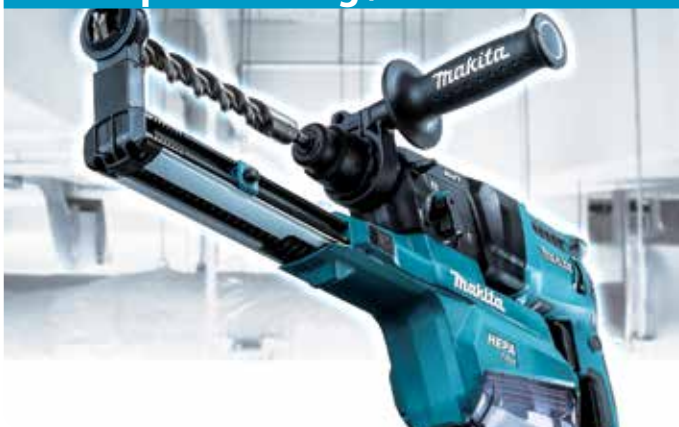

HP1630 - Hammer Drill

High power 710W motor. **HP1630 - Rs. 6,400**



85



Continuous rating input	710W
Capacity	Concrete: 16mm (5/8") Steel: 13mm (1/2") Wood: 30mm (1-3/16")
Impacts per minute (ipm)	0-48,000
No load speed (rpm)	0-3,200
Dimensions (L x W x H)	296x75x204mm (11-5/8"x2-15/16"x8")
Net weight	2.1kg (4.6lbs)
Power supply cord	2.0m (6.6ft)



Chuck key, Side grip

HP2070 - 2-Speed Hammer Drill

20 mm (3/4") 1,010 W 2-Speed Hammer Drill with Keyed Chuck

HP2070 - Rs. 14,600



419



Continuous rating input	1,010W
Capacity	Concrete: 20 mm (3/4") Steel Hi: 8 mm (5/16") Steel Lo: 16 mm (5/8") Wood Hi: 25 mm (1") Wood Lo: 40 mm (1-9/16")
Impacts Per Minute (IPM)	High: 0-58,000 Low: 0-24,000
No Load Speed (RPM)	High: 0-2,900 Low: 0-1,200
Overall Length	364 mm (14-3/8")
Net weight	2.6 kg (5.7 lbs)
Power supply cord	2.5 m (8.2 ft)



Chuck key, Side Grip, Depth Rod

HR1840 - Rotary Hammer

18 mm (11/16") 1.4 J Rotary Hammer, SDS-PLUS Bits

HR1840 - Rs. 12,500



459



Continuous rating input	470W
Impact Energy	EPTA-Procedure 05/2009: 1.4 J Our experimental conditions: 1.4 J
Capacity	Concrete: 18 mm / Core Bit: 35 mm Diamond Core Bit (Dry Type): 65 mm Steel: 13 mm / Wood: 24 mm
	0 - 4,800 0 - 2,100
Blows Per Minute (BPM)	87 dB(A)
No Load Speed (RPM)	98 dB(A)
Sound Pressure Level	Hammer Drilling Into Concrete: 10.0 m/s ²
Sound Power Level	Hammer Drilling Into Concrete: 1.5 m/s ²
Vibration Level	Drilling Into Metal: 3.0 m/s ²
Dimensions (L x W x H)	285x75x208 mm
Net weight	2.0 - 2.4 kg (4.3 - 5.3 lbs)
Power supply cord	2.5 m (8.2 ft)



Dust Cup (country-specific), Side Grip, Depth Gauge

HR2020 - Rotary Hammer

Simple and solid construction, yet powerful performance.

HR2020 - Rs. 12,600



419



Continuous rating Input	710W
Capacity	Concrete: 20mm (3/4") Steel: 13mm (1/2") Wood: 32mm (1-1/4")
Impacts per minute (ipm)	0 - 4,050
No load speed (rpm)	0 - 1,050
Overall length	352mm (13-7/8")
Net weight	2.3kg (5.1lbs)
Power supply cord	4.0m (13.1ft)



Depth Gauge, Side Grip (Tool does not come with bit.)

HR2230 - Rotary Hammer

High durability in mechanical parts, motor and carbon brush.

HR2230 - Rs. 13,700



325



Continuous rating input	710W
Impact energy	EPTA-Procedure 05/2009: 2.2J Our experimental conditions: 2.3J
Capacity	Concrete: 22mm (7/8") Steel: 13mm (1/2") Wood: 32mm (1-1/4")
Impacts per minute (ipm)	0 - 4,050
No load speed (rpm)	0 - 1,050
Sound pressure level	89dB(A)
Sound power level	100dB(A)
Vibration level	hammer drilling: 15m/s ² Drilling: 2.5m/s ²
Dimensions (L x W x H)	357x84x214mm (14"x3-5/16"x8-3/8")
Net weight	2.6kg (5.8lbs)
Power supply cord	2.5m (8.2ft)



Side Grip, Depth Gauge (Tool does not come with bit.)

HR2470 - Combination Hammer

High durability in mechanical parts, motor and carbon brush.

HR2470 - Rs. 14,600



Side Grip, Depth Gauge

Continuous rating input	780W
Impact energy	EPTA-Procedure 05/2009: 2.4J Our experimental conditions: 2.7J
Capacity	Concrete: 24mm (15/16") Steel: 13mm (1/2") Wood: 32mm (1-1/4")
Impacts per minute (ipm)	0 - 4,500
No load speed (rpm)	0 - 1,100
Sound pressure level	90dB(A)
Sound power level	101dB(A)
Vibration level	chiseling: 12.5m/s ² hammer drilling: 15.5m/s ² Drilling: 4.5m/s ²
Dimensions (L x W x H)	370x84x214mm (14-1/2"x3-5/16"x8-3/8")
Net weight	2.9kg (6.4lbs)
Power supply cord	2.5m (8.2ft)

HR2630 - Combination Hammer

26 mm (1") 2.4 J Combination Hammer, SDS-PLUS Bits

HR2630 - Rs. 16,700



Side grip, Depth gauge

Continuous rating input	800W
Impact Energy	EPTA-Procedure 05/2009: 2.4 J Concrete: 26 mm (1") Core Bit: 68 mm (2-11/16") Diamond Core Bit (Dry Type): 80 mm (3-1/8")
Capacity	Concrete: 26 mm (1") Steel: 13 mm (1/2") Wood: 32 mm (1-1/4")
Blows Per Minute (BPM)	0 - 4,600
No Load Speed (RPM)	0 - 1,200
Sound Pressure Level	90 dB(A)
Sound Power Level	101 dB(A)
Vibration Level	Hammer Drilling Into Concrete: 15.0 m/s ²
Dimensions (L x W x H)	385x77x209 mm (15-1/8"x3"x8-1/4")
Net weight	2.8 - 3.3 kg (6.3 - 7.2 lbs)
Power supply cord	2.5 m (8.2 ft)

HR2650 - Combination Hammer with Self Dust Collection

26 mm (1") 2.4 J Combination Hammer with HEPA Self Dust Collection, SDS-PLUS Bits

HR2650 - Rs. 26,100



Side Grip, Depth Gauge, Sealing Cap

Continuous rating input	800W
Impact Energy	EPTA-Procedure 05/2009: 2.4 J Our experimental conditions: 2.9 J
Capacity	Concrete: 26 mm (1") Core Bit: 68 mm (2-11/16") Diamond Core Bit (Dry Type): 80 mm (3-1/8") Steel: 13 mm (1/2") Wood: 32 mm (1-1/4")
Blows Per Minute (BPM)	0 - 4,600
No Load Speed (RPM)	0 - 1,200
Sound Pressure Level	91 dB(A)
Sound Power Level	102 dB(A)
Vibration Level	Hammer Drilling Into Concrete: 12.5 m/s ²
Dimensions (L x W x H)	604x89x228 mm (23-3/4"x3-1/2"x9")
Net weight	3.0 - 4.1 kg (6.7 - 9.1 lbs.)
Power supply cordz	2.5 m (8.2 ft.)

HR2651 - Combination Hammer with Self Dust Collection

26 mm (1") 2.4 J Combination Hammer with HEPA Self Dust Collection, SDS-PLUS Bits

HR2651 - Rs. 29,300



Side Grip, Depth Gauge, Sealing Cap

Continuous rating input	800W
Impact Energy	EPTA-Procedure 05/2009: 2.4 J Our experimental conditions: 2.9 J
Capacity	Concrete: 26 mm (1") Core Bit: 68 mm (2-11/16") Diamond Core Bit (Dry Type): 80 mm (3-1/8") Steel: 13 mm (1/2") Wood: 32 mm (1-1/4")
Blows Per Minute (BPM)	0 - 4,600
No Load Speed (RPM)	0 - 1,200
Sound Pressure Level	92 dB(A)
Sound Power Level	103 dB(A)
Vibration Level	Hammer Drilling Into Concrete: 11.5 m/s ²
Dimensions (L x W x H)	604x89x228 mm (23-3/4"x3-1/2"x9")
Net weight	3.1 - 4.2 kg (6.9 - 9.3 lbs.)
Power supply cordz	2.5 m (8.2 ft.)

HR2810 - Combination Hammer

28 mm (1-1/8") 2.8 J Combination Hammer, SDS-PLUS Bits

HR2810 - Rs. 26,700



Side grip, Depth gauge

Continuous rating input	800W
Impact Energy	EPTA-Procedure 05/2009: 2.8 J
Capacity	Concrete (with T.C.T. bit): 28 mm (1-1/8") Steel: 13 mm (1/2") Wood: 32 mm (1-1/4")
Blows Per Minute (BPM)	0 - 4,500
No Load Speed (RPM)	0 - 1,100
Sound Pressure Level	89 dB(A)
Sound Power Level	100 dB(A)
Vibration Level	Hammer Drilling Into Concrete: 20 m/s ² Drilling Into Metal: 2.5 m/s ² or less
Dimensions (L x W x H)	314x89x225 mm (12-3/8"x3-1/2"x8-7/8")
Net weight	3.4 - 3.8 kg (7.5 - 8.5 lbs)
Power supply cord	2.5 m (8.2 ft)

HR3200 - Combination Hammer

32 mm (1-1/4") 5.1 J Combination Hammer, SDS-PLUS Bits

HR3200C - Rs. 50,000



Depth gauge, Side grip, Grease vessel

Continuous rating input	850W
Impact Energy	EPTA-Procedure 05/2009: 5.1 J
Capacity	Concrete (with T.C.T. bit): 32 mm (1-1/4") Steel: 13 mm (1/2") Wood: 32 mm (1-1/4")
Blows Per Minute (BPM)	1,650 - 3,300
No Load Speed (RPM)	315 - 630
Sound Pressure Level	89 dB(A)
Sound Power Level	100 dB(A)
Vibration Level	Hammer Drilling Into Concrete: 18.0 m/s ² Drilling Into Metal: 2.5 m/s ² or less
Dimensions (L x W x H)	398x108x239 mm (15-5/8"x4-1/4"x9-3/8")
Net weight	4.8 - 5.2 kg (10.5 - 11.5 lbs)
Power supply cord	5.0 m (16.4 ft)

HR4013 - Rotary Hammer

40 mm (1-9/16") 8.0 J AVT SOFT NO LOAD Rotary Hammer, SDS-MAX Bits

HR4013C - Rs. 65,000



Depth gauge, Side handle, Bit grease

Continuous rating input	1,100W
Impact Energy	EPTA-Procedure 05/2009: 8 J
Capacity	Concrete (with T.C.T. bit): 40 mm Concrete (with Core bit): 105 mm
Blows Per Minute (BPM)	1,450 - 2,900
No Load Speed (RPM)	250 - 500
Sound Pressure Level	92 dB(A)
Sound Power Level	103 dB(A)
Vibration Level	Chiselling Function with Side Handle: 4.5 m/s ² Chiselling Function with Side Grip: 4.5 m/s ² Hammer Drilling Into Concrete: 5.0 m/s ²
Dimensions (L x W x H)	479x112x263 mm (18-11/16"x4-3/8"x10-3/8")
Net weight	6.8 - 6.9 kg (14.9 - 15.3 lbs)
Power supply cord	5.0 m (16.4 ft)

HR4003 - Rotary Hammer

40 mm (1-9/16") 8.3 J Rotary Hammer, SDS-MAX Bits

HR4003C - Rs. 60,800



Depth gauge, Side handle, Bit grease

Continuous rating input	1,100W
Impact Energy	EPTA-Procedure 05/2009: 8.3 J
Capacity	Concrete (with T.C.T. bit): 40 mm Concrete (with Core bit): 105 mm
Blows Per Minute (BPM)	1,450 - 2,900
No Load Speed (RPM)	250 - 500
Sound Pressure Level	92 dB(A)
Sound Power Level	103 dB(A)
Vibration Level	Chiselling Function with Side Handle: 9.0 m/s ² Chiselling Function with Side Grip: 9.0 m/s ² Hammer Drilling Into Concrete: 10.0 m/s ²
Dimensions (L x W x H)	479x106x263 mm (18-11/16"x4-3/16"x10-3/8")
Net weight	6.2 - 6.4 kg (13.7 - 14.1 lbs)
Power supply cord	5.0 m (16.4 ft)

HR4002 - Rotary Hammer

40 mm (1-9/16") 6.1 J Rotary Hammer, SDS-MAX Bits

HR4002 - Rs. 42,400



350



Continuous rating input	1,050W
Impact Energy	EPTA-Procedure 05/2009: 6.1 J
Capacity	Concrete (with T.C.T. bit): 40 mm Concrete (with Core bit): 105 mm
Blows Per Minute (BPM)	2,500
No Load Speed (RPM)	680
Sound Pressure Level	92 dB(A)
Sound Power Level	103 dB(A)
Vibration Level	Hammer Drilling Into Concrete: 17.5 m/s ²
Dimensions (L x W x H)	458x114x256 mm (18"x4-1/2"x10-1/8")
Net weight	6.6 - 6.8 kg (14.6 - 15.0 lbs)
Power supply cord	5.0 m (16.4 ft)



Side grip, Bit grease, Depth gauge

HR5212 - Rotary Hammer

52 mm (2-1/16") 20.0 J AVT SOFT NO LOAD Rotary Hammer, SDS-MAX Bits

HR5212C - Rs. 90,300



175



AVT SOFT NO LOAD
ANTI VIBRATION TECHNOLOGY



Side handle (D), Side grip, Depth gauge, Grease vessel

Continuous rating input	1,510W
Impact Energy	EPTA-Procedure 05/2009: 20 J
Capacity	Concrete (with T.C.T. bit): 52 mm Concrete (with Core bit): 160 mm
Blows Per Minute (BPM)	1,100 - 2,250
No Load Speed (RPM)	150 - 310
Sound Pressure Level	98 dB(A)
Sound Power Level	109 dB(A)
Vibration Level	Chiselling Function with Side Handle: 7.0 m/s ² Chiselling Function with Side Grip: 8.0 m/s ² Hammer Drilling Into Concrete: 9.0 m/s ²
Dimensions (L x W x H)	599x140x287 mm (23-1/2"x5-1/2"x11-1/4")
Net weight	11.9 - 12.0 kg (26.2 - 26.5 lbs)
Power supply cord	5.0 m (16.4 ft)

HR5202 - Rotary Hammer

52 mm (2-1/16") 19.1 J Rotary Hammer, SDS-MAX Bits

HR5202C - Rs. 82,900



175



Continuous rating input	1,510W
Impact energy	EPTA-Procedure 05/2009: 19.1 J Our experimental conditions: 21 J
Capacity	Concrete (with T.C.T. bit): 52mm Concrete (with Core bit): 160mm
Impacts per minute (ipm)	1,100 - 2,250
No load speed (rpm)	150 - 310
Sound pressure level	99dB(A)
Sound power level	110dB(A)
Vibration level	Chiselling Function with Side Handle: 10.5 m/s ² Chiselling Function with Side Grip: 10.5 m/s ² Hammer Drilling Into Concrete: 17.0 m/s ²
Dimensions (L x W x H)	599x134x287mm (23-1/2"x5-1/4"x11-1/4")
Net weight	10.9kg (24.1lbs)
Power supply cord	5.0m (16.4ft)



Side handle (D), Side grip, Depth gauge, Grease vessel

Demolition Hammer



HK1820 - Power Scraper

Compact and lightweight. One-touch sliding chuck.

HK1820 - Rs. 46,600

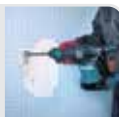

350



Continuous rating input	550W
Impact energy	EPTA-Procedure 05/2009: 3.1 J Our experimental conditions: 3.9 J
Impacts per minute (ipm)	0-3,200
Dimensions (L x W x H)	351x102x203mm (13-3/4"x4"x8")
Net weight	3.4kg (7.5lbs)
Power supply cord	5.0m (16.4ft)



Bull Point, Scaling Chisel, Scaling Chisel (for tile), Hook Complete

HM0810TA - Demolition Hammer

Perfect combination of power, durability and compact design (with two actin sliding chuck).

HM0810TA - Rs. 32,000



105



Continuous rating input	900W
Impact energy	EPTA-Procedure 05/2009: 7.2 J Our experimental conditions: 7.6 J
Impacts per minute (ipm)	2,900
Sound pressure level	92dB(A)
Sound power level	103dB(A)
Vibration level	chiselling: 14m/s ²
Overall length	428mm (16-7/8")
Net weight	5.5kg (12.1lbs)
Power supply cord	5.0m (16.4ft)



Bull Point, Hex Wrench, Side Grip

HM0870 - Demolition Hammer

7.6 J Demolition Hammer, SDS-MAX Bits

HM0870C - Rs. 36,800

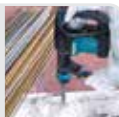

350



Continuous rating input	1,100W
Impact Energy	EPTA-Procedure 05/2009: 7.6 J
Blows Per Minute (BPM)	1,100 - 2,650
Sound Pressure Level	87 dB(A)
Sound Power Level	98 dB(A)
Vibration Level	Chiselling Function with Side Handle: 11.0 m/s ² Chiselling Function with Side Grip: 11.5 m/s ²
Dimensions (L x W x H)	449x109x230 mm (17-3/4"x4-1/4"x9")
Net weight	5.1 - 5.3 kg (11.1 - 11.6 lbs)
Power supply cord	5.0 m (16.4 ft)



Grease for Bit, Side Handle, (Tool does not come with bull point.)

HM1213 - Demolition Hammer

18.6 J AVT SOFT NO LOAD Demolition Hammer, SDS-MAX Bits

HM1213C - Rs. 72,500



175



AVT SOFT NO LOAD
ANTI VIBRATION TECHNOLOGY



Bull point, Bit grease, Side handle

Continuous rating input	1,510W
Impact Energy	EPTA-Procedure 05/2009: 18.6 J
Blows Per Minute (BPM)	950 - 1,900
Sound Pressure Level	75 dB(A)
Sound Power Level	95 dB(A)
Vibration Level	Chiselling Function with Side Handle: 8.0 m/s ² Chiselling Function with Side Grip: 8.0 m/s ²
Dimensions (L x W x H)	576x149x265 mm (22-3/4"x5-7/8"x10-3/8")
Net weight	10.8 kg (23.7 lbs)
Power supply cord	5.0 m (16.4 ft)



HM1205 - Demolition Hammer

19.1 J Demolition Hammer,
SDS-MAX Bits

HM1205C - Rs.63,900



175



Continuous rating input	1,510W
Impact Energy	EPTA-Procedure 05/2009: 19.1 J
Blows Per Minute (BPM)	950 - 1,900
Sound Pressure Level	79 dB(A)
Sound Power Level	93 dB(A)
Vibration Level	Chiselling Function with Side Handle: 18.5 m/s ²
Dimensions (L x W x H)	576x128x265 mm (22-3/4"x5"x10-3/8")
Net weight	9.7 kg (21.5 lbs)
Power supply cord	5.0 m (16.4 ft)



Bull Point, Bit Grease, Side Handle

HM1306 - Demolition Hammer

21.7 J Demolition Hammer,
30 mm Hex Shank

HM1306 - Rs. 70,000



204



Continuous rating input	1,510W
Impact energy	EPTA-Procedure 05/2009: 21.7J
	Our experimental conditions: 28.8J
Impacts per minute (ipm)	1,450
Dimensions (L x W x H)	652x121x231mm (25-3/4"x4-3/4"x9-1/8")
Net weight	15.1kg (33.3lbs)
Power supply cord	5.0m (16.4ft)



Bull Point, Wrench, Side Handle, Oil Supply 100mL

HM1812 - Electric Breaker

72.8 J AVT SOFT NO LOAD Electric Breaker,
28.6 mm Hex Shank

HM1812 - Rs. 1,81,000



AVT SOFT NO LOAD
ANTI VIBRATION TECHNOLOGY



Bull point, Hex wrench

Continuous rating input	2,000W
Impact Energy	EPTA-Procedure 05/2009: 72.8 J
Blows Per Minute (BPM)	870
Sound Pressure Level	96 dB(A)
Sound Power Level	107 dB(A)
Dimensions (L x W x H)	843x210x608 mm (33-1/4"x8-1/4"x24")
Net weight	31.3 kg (69 lbs)
Power supply cord	5.0 m (16.4 ft)



AVT
ANTI VIBRATION TECHNOLOGY

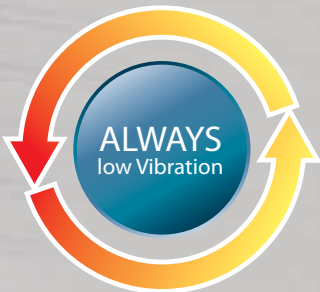

SOFT NO LOAD

Under load Active dynamic vibration absorber

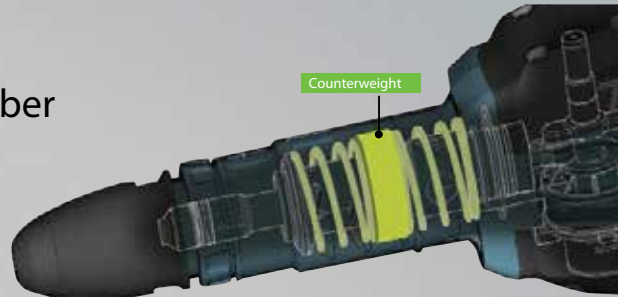
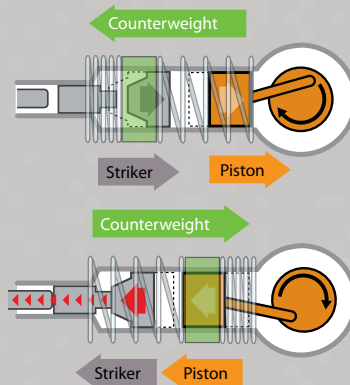

Vibration is absorbed efficiently by the Counterweight's dynamic action produced by our innovative active mechanism.

During no-load Suppression of motor speed

- reduces vibration of tool body when idling, accordingly decreases the amount of vibration to operator's hands during a day's operation.
- minimizes deflection of bit tip from aiming point when starting chipping.

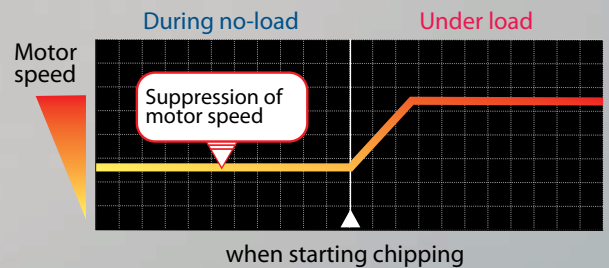

Cutting



4100KB - Dustless Cutter

125 mm (5") 1,400 W Dustless Cutter, Dry Type

4100KB - Rs. 12,500



303



Continuous rating input	1,400W
Blade Diameter	125 mm (5")
Max Cutting Capacity	40.0 mm (1-9/16")
No Load Speed (RPM)	12,200
Vibration Level	Concrete Cutting: 6.0 m/s ²
Sound Pressure Level	96 dB(A)
Sound Power Level	107 dB(A)
Dimensions (L x W x H)	231x220x179 mm
Net weight	3.0 kg (6.6 lbs.)
Power supply cord	2.5 m (8.2 ft.)



Diamond Wheel, Dust Bag, Wrench, Hex Wrench

4100NH3 - Cutter

Redesigned base with grooved back surface for smoother operation.

4100NH3Z - Rs. 7,700



303



Continuous rating input	1,200W
Capacity	Max. cutting: 32 mm (1-1/4")
Blade diameter	110 mm (4-3/8")
No load speed (rpm)	13,000
Dimensions (L x W x H)	227x209x166mm (8-15/16"x8-1/4"x6-1/2")
Net weight	2.9kg (6.4lbs)
Power supply cord	2.0m (6.6ft)



Wrench, Hex Wrench, Water Supply Fixture (for some countries), (Tool does not come with diamond wheel.)

4112HS - Angle Cutter

305 mm (12") 2,400 W SJS Angle Cutter

4112HS - Rs. 60,000



204



Continuous rating input	2,400W
Capacity	Max cutting : 100 mm (4")
Blade Diameter	305 mm (12")
No Load Speed (RPM)	5,000
Overall Length	648 mm (25-1/2")
Net weight	10.4 kg (22.9 lbs)
Power supply cord	2.5 m (8.2 ft)



Socket wrench

4114S - Angle Cutter

355 mm (14") 2,400 W SJS Angle Cutter

4114S - Rs. 65,000



204



Continuous rating input	2,400W
Capacity	Max cutting : 125 mm (5")
Wheel Diameter	355 mm (14")
Hole dia.	25.4 mm (1")
No Load Speed (RPM)	3,500
Dimensions (L x W x H)	673x240x329 mm (26-1/2"x9-1/2"x13")
Net weight	10.8 kg (23.9 lbs)
Power supply cord	2.5 m (8.2 ft)



Wrench (Tool does not come with diamond wheels.)

SG1251J - Wall Chaser

Clean, compact and comfortable.

SG1251J - Rs. 60,000



318



Continuous rating input	1,400W
Capacity	Depth: 0-30 mm (0 - 1-3/16") Width: 6-30 mm (1/4 - 1-3/16")
Blade Diameter	125 mm (5")
No Load Speed (RPM)	10,000
Dimensions (L x W x H)	350x151x178 mm (13-3/4"x5-15/16"x7")
Net weight	4.3 kg (9.5 lbs)
Power supply cord	5.0 m (16.4 ft)



Diamond wheel x2, Hex wrench, Lock nut wrench

4131 - Metal Cutter

185 mm (7-1/4") 1,100 W Metal Cutter

4131 - Rs. 35,000



303



Continuous rating input	1,100W
Blade Diameter	185 mm (7-1/4")
Capacity	Max cutting : 63 mm (2-1/2")
No Load Speed (RPM)	3,500
Overall Length	358 mm (14-1/8")
Net weight	4.8 kg (11.3 lbs)
Power supply cord	2.5 m (8.2 ft)



Carbide-Tipped Saw Blade, Hex Wrench, Safety Goggles



LC1230 - Metal Cutting Saw

305 mm (12") 1,750 W Metal Cutting Saw

LC1230 - Rs. 39,000



203



Continuous rating input	1,750W
Blade Diameter	305 mm (12")
Max Cutting Capacity	90°: 115 mm (4-1/2")
	90°: 75 x 150 mm (2-15/16" x 5-7/8")
	45°: 90 mm (3-1/2")
	45°: 85 x 85 mm (3-5/16" x 3-5/16")
No Load Speed (RPM)	1,300
Dimensions	516x306x603 mm
(L x W x H)	(20-1/4"x12"x23-3/4")
Net weight	19.3 kg (42.5 lbs)
Power supply cord	2.5 m (8.2 ft)

Carbide-Tipped Saw Blade (for mild steel), Socket Wrench, Safety Goggles

LW1400 - Portable Cut-off

355 mm (14") 2,200 W Toolless Portable Cut-Off

LW1400 - Rs. 20,900



203



Continuous rating input	2,200W
Wheel Diameter	355 mm (14")
No Load Speed (RPM)	3,800
Capacity at 90°	Round: 127 mm (5")
	Rectangular: 115x130 mm
	Rectangular: 102x194 mm
	Rectangular: 70x233 mm
Capacity at 45°	Round: 127 mm
	Rectangular: 115x103 mm
Vibration Level	2.5 m/s ² or less
Sound Pressure Level	102 dB(A)
Sound Power Level	110 dB(A)
Dimensions	530x295x640 mm
(L x W x H)	(20-7/8"x11-5/8"x25-1/4")
Net weight	18.7 kg (41.2 lbs)
Power supply cord	2.5 m (8.2 ft)

Abrasive cut-off wheel, Socket wrench

LW1401 - Portable Cut-off

355 mm (14") 2,200 W Portable Cut-Off

LW1401 - Rs. 17,800



203



Continuous rating input	2,200W
Wheel Diameter	355 mm (14")
No Load Speed (RPM)	3,800
Capacity at 90°	Round: 127 mm (5")
	Rectangular: 115x130 mm
	Rectangular: 102x194 mm
	Rectangular: 70x233 mm
Capacity at 45°	Round: 127 mm
	Rectangular: 115x103 mm
Vibration Level	2.5 m/s ² or less
Sound Pressure Level	102 dB(A)
Sound Power Level	110 dB(A)
Dimensions	500x295x640 mm
(L x W x H)	(19-3/4"x11-5/8"x25-1/4")
Net weight	18.3 kg (40.3 lbs)
Power supply cord	2.5 m (8.2 ft)

Abrasive cut-off wheel, Socket wrench

2107FK - Portable Band Saw

120 x 120 mm (4-3/4" x 4-3/4") 710 W
Variable Speed Portable Band Saw with Light

2107FK - Rs. 48,000



303



Continuous rating input	710W
Capacity	Round: 120 mm (4-3/4")
	Rectangular workpiece without stand:
	120x120 mm (4-3/4"x4-3/4")
Blade speed	60 m (200 ft) - 105 m (350 ft) / min
Dimensions	508x188x256 mm
(L x W x H)	(20"x7-3/8"x10-1/8")
Net weight	6.3 kg (13.9 lbs)
Power supply cord	2.5 m (8.2 ft)

Band Saw Blade, Hex Wrench

JR3050T - Recipro Saw

Well built and well balanced Mid-class.

JR3050CT - Rs. 13,000



303



Continuous rating Input	1,010W
Capacity	Pipe : 90mm (3-1/2")
	Wood : 90mm (3-1/2")
Length of stroke	28mm (1-1/8")
Strokes per minute (spm)	0-2,800
Dimensions (L x W x H)	452 x 97 x 170mm
	(17-3/4" x 3-13/16" x 6-11/16")
Net weight	3.3kg (7.3lbs)
Power supply cord	2.5m (8.2ft)



Recipro Saw Blade Set

JR3070CT - Recipro Saw

Extra-low vibration and extra power.

JR3070CT - Rs. 23,000



303



Continuous rating Input	1,510W
Capacity	Pipe : 130mm (5-1/8")
	Wood : 255mm (10")
Length of stroke	32mm (1-1/4")
Strokes per minute (spm)	0-2,800
Dimensions (L x W x H)	485 x 99 x 181mm
	(19-1/8" x 3-7/8" x 7-1/8")
Net weight	4.6kg (10.0lbs)
Power supply cord	2.5m (8.2ft)



Recipro Saw Blade (3pcs.)

ANTI VIBRATION TECHNOLOGY

JS1601 - Straight Metal Shear

1.6 mm (16 Ga) Straight Metal Shear

JS1601 - Rs. 32,000



459



Continuous rating input	380W
Capacity	Steel up to 400 N/mm ² : 1.6mm
	Steel up to 600 N/mm ² : 1.2mm
	Steel up to 800 N/mm ² : 0.8mm
	Aluminum up to 200 N/mm ² : 2.5mm
Min. cutting radius	250mm (9-7/8")
Strokes per minute (spm)	4,500
Dimensions	320x70x78mm
(L x W x H)	(12-5/8"x2-3/4"x3-1/16")
Net weight	1.4kg (3.1lbs)
Power supply cord	2.5m (8.2ft)



Hex wrench 3, Thickness gauge

JS1602 - Metal Shear

tor housing and rear cover provide more control and better maneuverability.

JS1602 - Rs. 35,000



459



Continuous rating Input	380W
Capacity	Steel up to 400 N/mm ² : 1.6mm
	Steel up to 600 N/mm ² : 1.2mm
	Steel up to 800 N/mm ² : 0.8mm
	Aluminum up to 200 N/mm ² : 2.5mm
Min. cutting radius	30mm (1-3/16")
Strokes per minute (spm)	4,000
Dimensions (L x W x H)	255x74x146mm
	(10"x2-15/16"x5-3/4")
Net Weight	1.6kg (3.5lbs)
Power supply cord	2.5m (8.2ft)



Hex Wrench



JS3201 - Metal Shear

3.2 mm (10 Ga) Metal Shear

JS3201 - Rs. 38,000



303



Continuous rating input	710W
Capacity	Steel up to 400 N/mm ² : 3.2 mm Steel up to 600 N/mm ² : 2.5 mm Steel up to 800 N/mm ² : 1.5 mm Aluminum up to 200 N/mm ² : 4.0 mm
Min. cutting radius	50 mm (2")
Strokes Per Minute (SPM)	1,600
Dimensions (L x W x H)	213x90x239 mm (8-3/8"x3-1/2"x9-3/8")
Net weight	3.4 kg (7.5 lbs)
Power supply cord	2.5 m (8.2 ft)

Shear blades set, Hex Wrench, Thickness Gauge

JN1601 - Nibbler

3.2 mm (10 Ga) Metal Shear

JN1601 - Rs. 31,000



411



Continuous rating input	550W
Capacity	Steel up to 400 N/mm ² : 1.6 mm Steel up to 600 N/mm ² : 1.2 mm Steel up to 800 N/mm ² : 0.8 mm Aluminum up to 200 N/mm ² : 2.5 mm
Min. cutting radius	Outside edge: 50 mm (2") Inside edge: 45 mm (1-3/4")
Strokes Per Minute (SPM)	2,200
Overall Length	261 mm (10-1/4")
Net weight	1.6 kg (3.6 lbs)
Power supply cord	2.0 m (6.6 ft)

Hex Wrench, Wrench, Punch, Die

JN3201 - Nibbler

3.2 mm (10 Ga) Nibbler

JN3201 - Rs. 47,000



303



Continuous rating Input	710W
Capacity	Steel up to 400 N/mm ² : 3.2mm Steel up to 600 N/mm ² : 2.5mm Steel up to 800 N/mm ² : 1.0mm Aluminum up to 200 N/mm ² : 3.5mm
Min. cutting radius	Outside edge: 128mm (5-1/16") Inside edge: 120mm (4-3/4")
Strokes per minute (spm)	1,300
Dimensions (L x W x H)	225x90x254mm (8-7/8"x1/2"x10")
Net weight	3.4kg (7.4lbs)
Power supply cord	2.5m (8.2ft)

Punch, Die, Wrench 50, Hex wrench, Washer

Grinding / Sanding



9553NB - Angle Grinder

Compact yet Powerful one-hand Grinder.

9553NB - Rs. 5,800



325



Continuous rating Input	710W
Wheel diameter	100mm (4")
No load speed (rpm)	11,000
Dimensions (L x W x H)	258 x 118 x 97mm (10-1/8"x4-5/8"x3-13/16")
Net weight	1.8kg (3.9lbs)
Power supply cord	2.5m (8.2ft)

Depressed Center Wheel, Lock Nut Wrench, Side Grip

9553B - Angle Grinder

Compact yet powerful grinder with toggle switch.

9553B - Rs. 5,900



325



Continuous rating input	710W
Wheel diameter	100 mm (4")
No load speed (rpm)	11,000
Dimensions (L x W x H)	258x118x97 mm (10-1/8"x4-5/8"x3-13/16")
Net weight	1.5 - 1.9 kg (3.3 - 4.1 lbs)
Power supply cord	2.5 m (8.2 ft)

Depressed center wheel, Lock nut wrench

GA4032 - Angle Grinder

Small circumference barrel grip and ergonomically designed side grip angle for easy handling

GA4032 - Rs. 5,400



459



Continuous rating input	720W
Wheel diameter	100 mm (4")
No load speed (rpm)	9,000
Dimensions (L x W x H)	259x118x104 mm (10-1/4"x4-5/8"x4-1/8")
Net weight	1.67 - 1.96 kg (3.68 - 4.32 lbs)
Power supply cord	2.5 m (8.2 ft)

Depressed Center Wheel, Lock Nut Wrench

9556HB - Angle Grinder

High durability & performance with toggle switch

9556HB - Rs. 6,300



325



Continuous rating input	840W
Wheel diameter	100mm (4")
No load speed (rpm)	11,000
Dimensions (L x W x H)	273x118x97mm (10-3/4"x4-5/8"x3-13/16")
Net weight	1.8kg (3.9lbs)
Power supply cord	2.5m (8.2ft)

Depressed center wheel, Lock nut wrench, Side grip

GA4040 - Angle Grinder

"Super Joint System II" developed for effective vibration absorption.

GA4040 - Rs. 14,100



Continuous rating input	100 mm (4")
Wheel Diameter	11,000
No Load Speed (RPM)	Surface Grinding with
Vibration Level	Anti-Vibration Side Grip: 5.5 m/s ²
	Disc Sanding with Anti-Vibration Side Grip: 2.5 m/s ² or less
Sound Pressure Level	86 dB(A)
Sound Power Level	97 dB(A)
Dimensions (L x W x H)	303x117x111 mm (11-7/8"x4-5/8"x4-3/8")
Net weight	2.2 - 2.5 kg (4.9 - 5.6 lbs)
Power supply cord	2.5 m (8.2 ft)



Depressed Center Wheel, Lock Nut Wrench, Side Grip

9558HN - Angle Grinder

125 mm (5") 840 W Angle Grinder, Slide Switch

9558HN - Rs. 6,200



new



Continuous rating input	840W
Wheel Diameter	125 mm (5")
No Load Speed (RPM)	11,000
Dimensions (L x W x H)	271x139x106 mm (10-5/8"x5-1/2"x4-3/16")
Net weight	1.7 - 3.0 kg (3.8 - 6.6 lbs.)
Power supply cord	2.5 m (8.2 ft.)

Depressed Center Wheel, Side Grip, Wheel Cover, Lock Nut Wrench

9565CR - Angle Grinder

125 mm (5") 1,400 W SJS Angle Grinder, Anti-Restart Function, Soft Start, Slide Switch

9565CR - Rs. 13,600



new



Continuous rating input	1,400W
Wheel Diameter	125 mm (5")
No Load Speed (RPM)	12,000
Dimensions (L x W x H)	299x139x103 mm (11-3/4"x5-1/2"x4-1/16")
Net weight	2.4 - 3.5 kg (5.2 - 7.7 lbs.)
Power supply cord	2.5 m (8.2 ft)



Depressed Center Wheel, Side Grip, Wheel Cover, Lock Nut Wrench



To suppress vibration to operator



Structure of Super Joint System II

Leaf spring absorbs vibration and relieves shock during operation.



Absorption mechanism of vibration

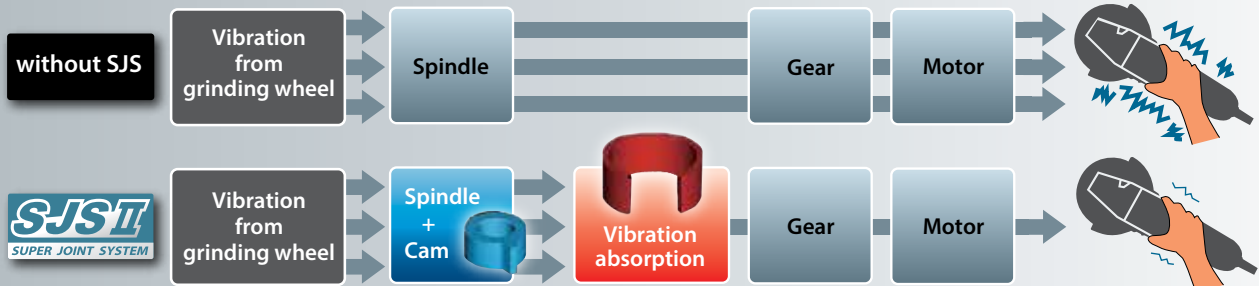

SJS II

SUPER JOINT SYSTEM



GA5010 - Angle Grinder

125 mm (5") 1,050 W Angle Grinder, Finger Trigger Switch

GA5010 - Rs. 10,800



303



Continuous rating input	1,050W
Wheel Diameter	125 mm (5")
No Load Speed (RPM)	12,000
Vibration Level	9.5 m/s ²
	Disc Sanding: 2.5 m/s ² or less
Sound Pressure Level	89 dB(A)
Sound Power Level	100 dB(A)
Dimensions (L x W x H)	356x139x112 mm (14"x5-1/2"x4-3/8")
Net weight	2.6 - 3.8 kg (5.8 - 8.4 lbs)
Power supply cord	2.5 m (8.2 ft)



Depressed Center Wheel, Lock Nut Wrench, Side Grip

GA5040R - Angle Grinder

125 mm (5") 1,100 W SJS II Angle Grinder, Anti-Restart Function, Soft Start, Slide Switch

GA5040R - Rs. 13,464



325



Continuous rating input	1,100W
Wheel Diameter	125 mm (5")
No Load Speed (RPM)	11,000
Vibration Level	Surface Grinding with Anti-Vibration Side Grip: 6.0 m/s ²
	Disc Sanding: 2.5 m/s ² or less
Sound Pressure Level	86 dB(A)
Sound Power Level	97 dB(A)
Dimensions (L x W x H)	303x140x116 mm (11-7/8"x5-1/2"x4-9/16")
Net weight	2.5 - 3.6 kg (5.4 - 8.0 lbs)
Power supply cord	2.5 m (8.2 ft)

SJS II
SUPER JOINT SYSTEM



Depressed center wheel, Diamond wheel Side grip, Anti-vibration grip (GA5040R), Lock nut wrench

9565CVL - Angle Grinder

125 mm (5") 1,400 W SJS Variable Speed Angle Grinder, Soft Start, Slide Switch

9565CVL - Rs. 21,400



318



Continuous rating input	1,400W
Wheel Diameter	125 mm (5")
No Load Speed (RPM)	2,000 - 7,800
Vibration Level	Surface Grinding: 4.5 m/s ²
	Disc Sanding: 2.5 m/s ² or less
Sound Pressure Level	86 dB(A)
Sound Power Level	97 dB(A)
Dimensions (L x W x H)	311x80x114 mm (12-1/4"x3-5/32"x4-1/12")
Net weight	2.1 - 2.6 kg (4.6 - 5.9 lbs)
Power supply cord	2.5 m (8.2 ft)

SUPER JOINT SYSTEM
SJS



Abrasive Disc, Pad, Head Cover, Lock Nut Wrench, Side Grip

GA5020C - Angle Grinder

125 mm (5") 1,450 W SJS Angle Grinder, Anti-Restart Function, Soft Start, Finger Trigger Switch

GA5020C - Rs. 13,100



253



Continuous rating input	1,450W
Wheel Diameter	125 mm (5")
No Load Speed (RPM)	10,000
Vibration Level	Surface Grinding: 9.5 m/s ²
	Disc Sanding: 2.5 m/s ² or less
Sound Pressure Level	90 dB(A)
Sound Power Level	101 dB(A)
Dimensions (L x W x H)	390x139x120 mm (15-3/8"x5-1/2"x4-3/4")
Net weight	2.9 - 4.1 kg (6.5 - 9.1 lbs)
Power supply cord	2.5 m (8.2 ft)

SUPER JOINT SYSTEM
SJS



Depressed Center Wheel, Lock Nut Wrench, Side Grip

GA7050 / GA7050R01 - Angle Grinder

180 mm (7") 2,000 W Angle Grinder, GA7050R01 (Anti-Restart Function), Soft Start, Large Trigger Switch

GA7050 - Rs. 11,200

GA7050R01 - Rs. 12,500



204



Continuous rating input	2,000W
Wheel Diameter	180 mm (7")
No Load Speed (RPM)	8,500
Vibration Level	Surface Grinding: 6.5 m/s ²
	Disc Sanding: 4.0 m/s ²
Sound Pressure Level	94 dB(A)
Sound Power Level	105 dB(A)
Dimensions (L x W x H)	GA7050: 432x200x132 mm (17"x7-7/8"x5-3/16")
	GA7050R01: 455x200x132 mm (17-7/8"x7-7/8"x5-3/16")
Net weight	GA7050: 3.98 - 5.00 kg (8.8 - 11.0 lbs)
	GA7050R01: 4.66 - 5.18 kg (10.3 - 11.4 lbs)
Power supply cord	2.5 m (8.2 ft)

▼ GA7050R01



Lock Nut Wrench, Side Grip (Tool does not come with depressed center wheel.)

GA7020 - Angle Grinder

180 mm (7") 2,200 W Angle Grinder, Large Trigger Switch

GA7020 - Rs. 12,200

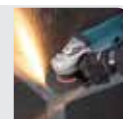

204



Continuous rating input	2,200W
Wheel Diameter	180 mm (7")
No Load Speed (RPM)	8,500
Vibration Level	Surface Grinding with Anti-Vibration Side Grip: 8.0 m/s ²
	Disc Sanding: 2.5 m/s ²
Sound Pressure Level	89 dB(A)
Sound Power Level	100 dB(A)
Dimensions (L x W x H)	473x200x140 mm (18-5/8"x7-7/8"x5-1/2")
Net weight	5.56 - 6.06 kg (12.26 - 13.36 lbs)
Power supply cord	2.5 m (8.2 ft)



Lock Nut Wrench, Side Grip (Tool does not come with depressed center wheel.)

GA7060R / GA7060 - Angle Grinder

180 mm (7") 2,200 W Angle Grinder, (GA7060R Anti-Restart Function), Soft Start, Large Trigger Switch



Continuous rating input	2,200W
Wheel Diameter	180 mm (7")
No Load Speed (RPM)	8,500
Vibration Level	Surface Grinding with Anti-Vibration Side Grip: 7.5 m/s ² Disc Sanding with Anti-Vibration Side Grip: 2.5 m/s ²
Sound Pressure Level	91 dB(A)
Sound Power Level	102 dB(A)
Dimensions (L x W x H)	GA7060R: 450x200x144 mm (17-3/4"x7-7/8"x5-5/8") GA7060: 450x200x144 mm (17-3/4"x7-7/8"x5-5/8")
Net weight	GA7060R: 5.42 - 5.93 kg (12 - 13.1 lbs) GA7060: 5.38 - 5.89 kg (11.9 - 13 lbs)
Power supply cord	2.5 m (8.2 ft)

▼ GA7060R



Side grip, Lock nut wrench

GA7061R / GA7061 - Angle Grinder

180 mm (7") 2,200 W SJS II Angle Grinder, (GA7061R Anti-Restart Function), Soft Start, Large Trigger Switch



Continuous rating input	2,200W
Wheel Diameter	180 mm (7")
No Load Speed (RPM)	8,500
Vibration Level	Surface Grinding with Anti-Vibration Side Grip: 6.5 m/s ² Disc Sanding with Anti-Vibration Side Grip: 2.5 m/s ²
Sound Pressure Level	91 dB(A)
Sound Power Level	102 dB(A)
Dimensions (L x W x H)	450x200x145 mm (17-3/4"x7-7/8"x5-3/4")
Net weight	GA7061R: 5.57 - 6.08 kg (12.3 - 13.4 lbs) GA7061: 5.53 - 6.04 kg (12.2 - 13.3 lbs)
Power supply cord	2.5 m (8.2 ft)

▼ GA7061R



Side grip, Lock nut wrench



GA7062 - Angle Grinder

180 mm (7") 2,200 W D-Handle Angle Grinder, Large Trigger Switch



Continuous rating input	2,200W
Wheel Diameter	180 mm (7")
No Load Speed (RPM)	8,500
Vibration Level	Surface Grinding w/ Anti-Vibration Side Grip: 7.5 m/s ² Surface Grinding w/ Normal Side Grip: 7.5 m/s ² Disc Sanding w/ Anti-Vibration Side Grip: 2.5 m/s ² Disc Sanding w/ Normal Side Grip: 2.5 m/s ²
Sound Pressure Level	91 dB(A)
Sound Power Level	102 dB(A)
Dimensions (L x W x H)	450x200x144 mm
Net weight	5.51 - 6.02 kg (12.2 - 13.3 lbs)
Power supply cord	2.5 m (8.2 ft)



Abrasive Disc, Side Grip, Wheel Cover, Lock Nut Wrench

GA7063R - Angle Grinder

180 mm (7") 2,200 W SJS II Angle Grinder, Anti-Restart Function, Soft Start, Large Trigger Switch



Continuous rating input	2,200W
Wheel Diameter	180 mm (7")
No Load Speed (RPM)	8,500
Vibration Level	Surface Grinding w/ Anti-Vibration Side Grip: 6.5 m/s ² Surface Grinding w/ Normal Side Grip: 7.0 m/s ² Disc Sanding w/ Anti-Vibration Side Grip: 2.5 m/s ² or less Disc Sanding w/ Normal Side Grip: 2.5 m/s ²
Sound Pressure Level	91 dB(A)
Sound Power Level	102 dB(A)
Dimensions (L x W x H)	450x200x145 mm
Net weight	5.70 - 6.21 kg (12.6 - 13.7 lbs)
Power supply cord	2.5 m (8.2 ft)



Abrasive Disc, Side Grip, Wheel Cover, Lock Nut Wrench



GA7030 - Angle Grinder

180 mm (7") 2,400 W Angle Grinder, Large Trigger Switch

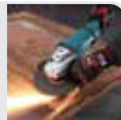

Continuous rating input	2,400W
Wheel Diameter	180 mm (7")
No Load Speed (RPM)	8,500
Vibration Level	Surface Grinding: 6.5 m/s ² Disc Sanding: 2.5 m/s ²
Sound Pressure Level	89 dB(A)
Sound Power Level	100 dB(A)
Dimensions (L x W x H)	511x200x140 mm (20-1/8"x7-7/8"x5-1/2")
Net weight	6.06 - 6.56 kg (13.36 - 14.46 lbs)
Power supply cord	2.5 m (8.2 ft)



Lock Nut Wrench, Side Grip (Tool does not come with depressed center wheel.)

GA7040S - Angle Grinder

180 mm (7") 2,600 W Angle Grinder, Soft Start, Large Trigger Switch



Continuous rating input	2,600W
Wheel Diameter	180 mm (7")
No Load Speed (RPM)	8,500
Vibration Level	Surface Grinding: 7.5 m/s ² Disc Sanding: 2.5 m/s ²
Sound Pressure Level	90 dB(A)
Sound Power Level	101 dB(A)
Dimensions (L x W x H)	511x200x140 mm (20-1/8"x7-7/8"x5-1/2")
Net weight	6.45 - 6.95 kg (14.2 - 15.3 lbs)
Power supply cord	2.5 m (8.2 ft)



Lock nut wrench, Side grip

GA9050 / GA9050R01 - Angle Grinder

230 mm (9") 2,000 W Angle Grinder, (GA9050R01 Anti Restart Function), Soft Start, Large Trigger Switch



Continuous rating input	2,000W
Wheel Diameter	230 mm (9")
No Load Speed (RPM)	6,600
Vibration Level	Surface Grinding: 5.5 m/s ² Disc Sanding: 2.5 m/s ²
Sound Pressure Level	94 dB(A)
Sound Power Level	105 dB(A)
Dimensions (L x W x H)	GA9050: 432x250x132 mm (17"x9-7/8"x5-3/16") GA9050R01: 455x250x132 mm (17-7/8"x9-7/8"x5-3/16")
Net weight	GA9050: 4.64 - 6.94 kg (10.2 - 15.3 lbs) GA9050R01: 4.82 - 7.12 kg (10.6 - 15.7 lbs)
Power supply cord	2.5 m (8.2 ft)

▼ GA9050R01



Lock Nut Wrench, Side Grip (Tool does not come with depressed center wheel.)

GA9020 - Angle Grinder

230 mm (9") 2,200 W Angle Grinder, Large Trigger Switch

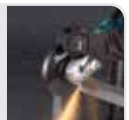

Continuous rating input	2,200W
Wheel Diameter	230 mm (9")
No Load Speed (RPM)	6,000
Vibration Level	Surface Grinding: 5.5 m/s ² Disc Sanding: 2.5 m/s ² or less
Sound Pressure Level	89 dB(A)
Sound Power Level	100 dB(A)
Dimensions (L x W x H)	473x249x140 mm (18-5/8"x9-3/4"x5-1/2")
Net weight	5.76 - 8.05 kg (12.7 - 17.8 lbs)
Power supply cord	2.5 m (8.2 ft)



Lock Nut Wrench, Side Grip (Tool does not come with depressed center wheel.)

GA9060R / GA9060 - Angle Grinder

230 mm (9") 2,200 W Angle Grinder, (GA9060R Anti-Restart Function), Soft Start, Large Trigger Switch



218



▼ GA9060R



Side grip, Lock nut wrench

Continuous rating input	2,200W
Wheel Diameter	230 mm (9")
No Load Speed (RPM)	6,600
Vibration Level	Surface Grinding with Anti-Vibration Side Grip: 6.0 m/s ² Disc Sanding with Anti-Vibration Side Grip: 2.5 m/s ² or less
Sound Pressure Level	91 dB(A)
Sound Power Level	102 dB(A)
Dimensions (L x W x H)	450x250x144 mm (17-3/4"x9-7/8"x5-5/8")
Net weight	GA9060R: 5.52 - 7.88 kg (12.8 - 17.4 lbs) GA9060: 5.50 - 7.86 kg (12.1 - 17.3 lbs)
Power supply cord	2.5 m (8.2 ft)

GA9061R / GA9061 - Angle Grinder

230 mm (9") 2,200 W SJS II Angle Grinder, (GA9061R Anti-Restart Function), Soft Start, Large Trigger Switch

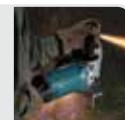

218



▼ GA9061R



Side grip, Lock nut wrench



Continuous rating input	2,200W
Wheel Diameter	230 mm (9")
No Load Speed (RPM)	6,600
Vibration Level	Surface Grinding with Anti-Vibration Side Grip: 5.5 m/s ² Disc Sanding with Anti-Vibration Side Grip: 2.5 m/s ² or less
Sound Pressure Level	91 dB(A)
Sound Power Level	102 dB(A)
Dimensions (L x W x H)	450x250x145 mm (17-3/4"x9-7/8"x5-3/4")
Net weight	GA9061R: 5.68 - 8.04 kg (12.5 - 17.7 lbs) GA9061: 5.63 - 7.99 kg (12.4 - 17.6 lbs)
Power supply cord	2.5 m (8.2 ft)

GA9030 - Angle Grinder

230 mm (9") 2,400 W Angle Grinder, Large Trigger Switch



204



Lock Nut Wrench, Side Grip (Tool does not come with depressed center wheel.)

Continuous rating input	2,400W
Wheel Diameter	230 mm (9")
No Load Speed (RPM)	6,600
Vibration Level	Surface Grinding: 6.5 m/s ² Disc Sanding: 2.5 m/s ² or less
Sound Pressure Level	90 dB(A)
Sound Power Level	101 dB(A)
Dimensions (L x W x H)	503x250x140 mm (19-3/4"x9-7/8"x5-1/2")
Net weight	6.26 - 8.55 kg (13.8 - 18.9 lbs)
Power supply cord	2.5 m (8.2 ft)

GA9040S - Angle Grinder

230 mm (9") 2,600 W Angle Grinder, Soft Start, Large Trigger Switch



204



Lock Nut Wrench, Side Grip (Tool does not come with depressed center wheel.)

Continuous rating input	2,600W
Wheel Diameter	230 mm (9")
No Load Speed (RPM)	6,600
Sound Pressure Level	90 dB(A)
Sound Power Level	101 dB(A)
Dimensions (L x W x H)	503x250x140 mm (19-3/4"x9-7/8"x5-1/2")
Net weight	6.62 - 8.91 kg (14.6 - 19.6 lbs)
Power supply cord	2.5 m (8.2 ft)

SA7000C - Angle Sander

180 mm (7") 1,600 W Variable Speed Angle Sander



204



Rubber Pad, Sanding Lock Nut, Lock Nut Wrench, Side Grip, Head Cover

Continuous rating input	1,600W
Abrasive Disc Size	180 mm (7")
Capacity	Pad: 180 mm (7")
No Load Speed (RPM)	0-4,000
Dimensions (L x W x H)	453x170x136 mm (17-7/8"x6-11/16"x5-3/8")
Net weight	3.5 - 3.6 kg (7.7 - 7.9 lbs)
Power supply cord	2.5 m (8.2 ft)

GV7000C - Disc Sander

180 mm (7") 900 W Variable Speed Disc Sander



303

new



Abrasive Disc, Rubber Pad, Lock Nut Wrench, Wrench, Side Grip

Continuous rating input	900W
Abrasive Disc Size	180 mm (7")
Capacity	Pad: 180 mm (7")
No Load Speed (RPM)	2,500-4,700
Overall Length	210 mm (8-1/4")
Net weight	2.1 kg (4.6 lbs.)
Power supply cord	2.5 m (8.2 ft)

9215SB - Disc Sander

Powerful 570W motor in well balanced body for fast and steady sanding.



100



Rubber Pad, Lock Nut Wrench, Wrench, Side Grip

Continuous rating Input	570W
Capacity	Wire cup brush: 110mm (4-3/8")
Abrasive disc diameter	150mm (5")
No load speed (rpm)	4,500
Overall length	225mm (8-7/8")
Net weight	2.9kg (6.3lbs)
Power supply cord	2.5m (8.2ft)

GV5010 - Disc Sander

125 mm (5") 440 W Disc Sander



64



Abrasive disc, Plastic pad, Side grip, Hex socket head bolt, Washer, Hex wrench

Continuous rating input	440W
Abrasive disc diameter	125mm (5")
Capacity	Pad: 120mm (4-3/4")
No load speed (rpm)	4,500
Dimensions (L x W x H)	200x74x181mm (7-7/8"x2-15/16"x7-1/8")
Net weight	1.2kg (2.6lbs)
Power supply cord	2.5m (8.2ft)

9237C - Polisher

180 mm (7") 1,200 W Variable Speed Polisher

9237C - Rs. 24,000



Continuous rating input	1,200W
Capacity	Wool Pad: 180 mm (7") Wool Bonnet: 180 mm (7")
No Load Speed (RPM)	0 - 3,200
Vibration Level	2.5 m/s ² or less
Vibration K Factor	1.5 m/s ²
Sound Pressure Level	83 dB(A)
Sound Power Level	94 dB(A)
Noise K factor	3 dB(A)
Dimensions (L x W x H)	431x198x187 mm (17"x7"-3/4"x7"-3/8")
Net weight	3.2 - 3.4 kg (7.0 - 7.5 lbs)
Power supply cord	2.5 m (8.2 ft)



Loop Handle / Side Handle, Hex Wrench, Accessory set

PO6000C - Random Orbit Polisher

150 mm (6") 900 W Random Orbit Polisher

PO6000C - Rs. 33,200



Continuous rating input	900W
Pad Size	150 mm (6")
Orbits Per Minute (OPM)	0 - 6,800
Strokes Per Minute (SPM)	0 - 13,600
No Load Speed (RPM)	0 - 780
Orbit Diameter	5.5 mm (7/32")
Vibration Level	Polishing: 7.0 m/s ²
Sound Pressure Level	83 dB(A)
Sound Power Level	94 dB(A)
Dimensions (L x W x H)	451x148x126 mm (17-3/4"x5-7/8"x5")
Net weight	2.8 - 3.0 kg (6.2 - 6.5 lbs)
Power supply cord	4.0 m (13.1 ft)



Side Grip (country-specific), Pad (country-specific), Hex Wrench

PO5000C - Random Orbit Polisher

125 mm (5") 900 W Random Orbit Polisher

PO5000C - Rs. 31,800



Continuous rating input	900W
Pad Size	125 mm (5")
Orbits Per Minute (OPM)	0 - 6,800
Strokes Per Minute (SPM)	0 - 13,600
No Load Speed (RPM)	0 - 780
Orbit Diameter	5.5 mm (7/32")
Vibration Level	Polishing: 6.5 m/s ²
Sound Pressure Level	81 dB(A)
Sound Power Level	92 dB(A)
Dimensions (L x W x H)	451x123x134 mm (17-3/4"x4-7/8"x5-1/4")
Net weight	2.8 - 3.0 kg (6.2 - 6.5 lbs)
Power supply cord	4.0 m (13.1 ft)



Side Grip (country-specific), Pad (country-specific), Hex Wrench

PV7000C - Polisher

180 mm (7") 900 W Variable 2-Speed Vertical Polisher

PV7000C - Rs. 22,800



Continuous rating input	Pad: 180 mm (7")
Capacity	Wool Bonnet: 180 mm (7")
No Load Speed (RPM)	600 - 2,100
Vibration Level	Polishing: 2.5 m/s ² or less
Sound Pressure Level	81 dB(A)
Sound Power Level	92 dB(A)
Overall Length	210 mm (8-1/4")
Net weight	2.1 kg (4.6 lbs)
Power supply cord	2.5 m (8.2 ft)



Pad, Wrench, Side Grip

PW5001C - Stone Polisher

125 mm (5") 900 W Stone Polisher

PW5001C - Rs. 33,900



Continuous rating input	900W
Capacity	Pad: 100-125 mm (4-5")
No Load Speed (RPM)	2,000-4,000
Overall Length	359 mm (14-1/8")
Net weight	2.3 - 2.6 kg (5.1 - 5.7 lbs)
Power supply cord	4.0 m (13.1 ft)



Rubber Pad 100(M14), Rubber Pad 100(5/8"), Side Grip, Wrench, Head Cover

PC5000C - Concrete Planer

Most Suitable for Planing Concrete.

PC5000C - Rs. 41,300



Continuous rating input	1,400W
Wheel diameter	125mm (5")
Hole dia.	22.23mm (7/8")
No load speed (rpm)	10,000
Dimensions (L x W x H)	437x235x195mm (17-1/8"x9-1/4"x7-5/8")
Net weight	4.0kg (8.9lbs)
Power supply cord	5.0m (16.4ft)



Offset diamond wheel, Lock nut wrench, Hex wrench, Dust bag assembly, Brush set

PC5001C - Concrete Planer

Front roller adjusts planing depth.
Auxiliary base for smoother planing.

PC5001C - Rs. 69,500



Continuous rating input	1,400W
Wheel diameter	125 mm (5")
No load speed (rpm)	10,000
Dimensions (L x W x H)	479x182x195 mm (18-13/16"x7-1/8"x7-5/8")
Net weight	4 kg (8.9 lbs)
Power supply cord	5.0 m (16.4 ft)



Offset diamond wheel, Lock nut wrench, Hex wrench, Dust bag assembly, Brush set

PC5010C - Concrete Planer

125 mm (5") 1,400 W SJS II Variable Speed Concrete Planer

PC5010C - Rs. 33,000



Continuous rating input	1,400W
Wheel Diameter	125 mm (5")
Hole Diameter	22.23 mm (7/8")
No Load Speed (RPM)	4,000 - 9,000
Dimensions (L x W x H)	350x231x179 mm (13-3/4"x9-1/8"x7")
Net weight	2.5 - 3.6 kg (5.5 - 7.9 lbs.)
Power supply cord	4.0 m (13.1 ft)



Offset Diamond Wheel, Lock Nut Wrench

GD0603 - Die Grinder

Easy handling, Compact Die grinder with new aesthetic design

GD0603 - Rs. 10,100



Continuous rating input	240W
Capacity	Collet: 6mm or 1/4"
Max wheel diameter	19mm
No load speed (rpm)	28,000
Diameter of grip	65mm
Circumference of grip	203mm
Dimensions (L x W x H)	289x64x67mm (11-3/8"x2-1/2"x2-5/8")
Net weight	0.97kg (2.1lbs)
Power supply cord	2.5m (8.2ft)



Spanner 10 (x2), Wheel points

GD0601 - Die Grinder

Small-circumference housing for easy handling.

GD0601 - Rs. 7,700



Continuous rating input	400W
Capacity	Collet: 3,6 mm or 1/8"; 1/4"
Wheel Diameter	38 mm (1-1/2")
No Load Speed (RPM)	25,000
Dimensions (L x W x H)	359x82x82 mm (14-1/8"x3-1/4"x3-1/4")
Net weight	1.68 - 1.84 kg (3.70 - 4.06 lbs)
Power supply cord	2.5 m (8.2 ft)



Wrench (2pcs.) (Tool does not come with wheel point.)

GD0810C - Die Grinder

8 mm (1/4") 750 W SJS Variable Speed Die Grinder, Slide Switch

GD0810C - Rs. 26,400



Continuous rating input	750W
Capacity	Collet: 3,6,8 mm or 1/8"; 1/4"
Wheel Diameter	50 mm (2")
No Load Speed (RPM)	1,800-7,000 (1/2, 13/16")
Overall Length	371 mm (14-5/8")
Net weight	1.9 kg (4.2 lbs)
Power supply cord	2.5 m (8.2 ft)



Wrench x2



GS5000 - Straight Grinder

750 W Straight Grinder

GS5000 - Rs. 25,800



Continuous rating input	750W
Wheel Diameter	125 mm (5")
Hole dia.	12,7,20 mm (1/2, 13/16")
No Load Speed (RPM)	5,600
Dimensions (L x W x H)	590x189x116 mm (23-1/4"x7-7/16"x4-9/16")
Net weight	5.0 - 5.2 kg (11.0 - 11.5 lbs)
Power supply cord	2.5 m (8.2 ft)



Grinding wheel (for some country only), Hex wrench, Wrenches (for some country only)

GS6000 - Straight Grinder

750 W Straight Grinder

GS6000 - Rs. 28,000



Continuous rating input	750W
Wheel Diameter	150 mm (6")
Hole dia.	12,7,20 mm (1/2, 13/16")
No Load Speed (RPM)	5,600
Dimensions (L x W x H)	590x216x130 mm (23-1/4"x8-1/2"x5-1/8")
Net weight	5.2 - 5.4 kg (11.4 - 12.0 lbs)
Power supply cord	2.5 m (8.2 ft)



Grinding wheel (for some country only), Hex wrench, Wrenches (for some country only)

TM3000CX1 - Multi Tool

320 W Multi Tool

TM3000CX1 - Rs. 18,000



Continuous rating input	320W
Strokes Per Minute (SPM)	6,000-20,000
Dimensions (L x W x H)	275x64x92 mm (10-7/8"x2-1/2"x3-5/8")
Net weight	1.4 - 1.5 kg (3.2 - 3.3 lbs)
Power supply cord	5.0 m (16.4 ft)



Oscillating multi tool accessories, Hex wrench

GB602 - Bench Grinder

150 mm (6") 250 W Bench Grinder

GB602 - Rs. 10,700



Continuous rating input	250W
Wheel Diameter	150 mm (6")
Wheel width	16 mm (5/8")
Hole dia.	12,7 mm (1/2")
H.P.	1/3
No Load Speed (RPM)	2,850 (50 Hz) / 3,450 (60 Hz)
Sound Pressure Level	74 dB(A)
Dimensions (L x W x H)	375x205x286 mm (14-9/16"x8"x11-17/64")
Net weight	9.31 - 9.08 kg (20.02 - 20.52 lbs)



Eye Shield, Protection Glasses

GB801 - Bench Grinder

205 mm (8") 550 W Bench Grinder

GB801 - Rs. 17,000



Continuous rating input	550W
Wheel Diameter	205 mm (8")
Wheel width	19 mm (3/4")
Hole dia.	15,88 mm (5/8")
H.P.	3/4
No Load Speed (RPM)	2,850 (50 Hz) / 3,450 (60 Hz)
Sound Pressure Level	77 dB(A)
Dimensions (L x W x H)	395x265x333 mm (15-9/16"x10-7/16"x13-7/64")
Net weight	19.91 - 19.63 kg (43.89 - 43.28 lbs)



Eye shield, Protection glasses

9031 - Belt Sander

Optimum for use in close quarters or on irregular shapes.

9031 - Rs. 25,400



Continuous rating input	550W
Belt size	30 x 533mm (1-3/16" x 21")
Belt speed	200 - 1,000m / min. (656 - 3,280ft/ min)
Overall length	380mm (15")
Net weight	2.1kg (4.6lbs)
Power supply cord	2.5m (8.2ft)

411



Abrasive Belts 10

9741 - Wheel Sander

100 x 120 mm (4" x 4-3/4") Wheel Sander

9741 - Rs. 25,000



Continuous rating input	860W
Wheel diameter	100 x 120mm (4" x 4-3/4")
No load speed (rpm)	3,500
Overall length	310mm (12-1/4")
Net weight	4.2kg (9.3lbs)
Power supply cord	5.0m (16.4ft)

100



Hex wrench x2, Joint for makita vacuum cleaner

BO3710 - Finishing Sander

1/3 Sheet 190 W Finishing Sander with Built-In Dust Extraction System

BO3710 - Rs. 6,600



Continuous rating input	190W
Pad Size	93 x 185 mm (3-5/8" x 7-1/4")
Abrasive Paper Size	93 x 228 mm (3-5/8" x 9")
Orbits Per Minute (OPM)	11,000
Strokes Per Minute (SPM)	22,000
Orbit Diameter	2.0 mm (1/16")
Vibration Level	Sanding Metal Plate: 3.5 m/s ²
Sound Pressure Level	72 dB(A)
Dimensions (L x W x H)	253x92x154 mm (10"x3-5/8"x6-1/16")
Net weight	1.6 kg (3.5 lbs)
Power supply cord	2.0 m (6.6 ft)

64



Abrasive Paper, Punch Plate, Dust Bag or Dust Box

BO4556 - Finishing Sander

1/4 Sheet 200 W Finishing Sander

BO4556 - Rs. 7,300



Continuous rating input	200W
Pad Size	112 x 102 mm (4-3/8" x 4")
Abrasive Paper Size	114 x 140 mm (4-1/2" x 5-1/2")
Orbits Per Minute (OPM)	14,000
Dimensions (L x W x H)	131x112x141 mm (5-1/8"x4-3/8"x5-9/16")
Net weight	1.1 kg (2.5 lbs)
Power supply cord	2.0 m (6.6 ft)

419



Abrasive Paper, Dust Bag, Punch Plate

BO5031 - Random Orbit Sander

125 mm (5") 300 W Random Orbit Sander with Built-In Dust Extraction System

BO5031 - Rs. 11,800



Continuous rating input	300W
Pad diameter	123 mm (4-7/8")
Abrasive Disc Size	125 mm (5")
Orbits Per Minute (OPM)	4,000-12,000
Dimensions (L x W x H)	153x123x153 mm (6"x4-7/8"x6")
Net weight	1.3 kg (3 lbs)
Power supply cord	2.0 m (6.6 ft)

419



Abrasive Disc, Dust Bag or Dust Box

BO6030 - Random Orbit Sander

150 mm (6") 310 W Variable Speed Random Orbit Sander with Built-In Dust Extraction System

BO6030 - Rs. 20,200



Continuous rating input	310W
Pad diameter	150 mm (6")
Abrasive Disc Size	150 mm (6")
Orbits Per Minute (OPM)	4,000-10,000
Overall Length	309 mm (12-1/8")
Orbit Diameter	3.0 mm (1/8")
Net weight	2.4 kg (5.2 lbs)
Power supply cord	2.5 m (8.2 ft)

419



Abrasive Disc, Hex Wrench, Dust Bag



Sawing



LS1219L - Slide Compound Miter Saw

305 mm (12") 1,800 W Slide Compound Miter Saw

LS1219L - Rs. 86,500



153

Continuous rating input	1,800W
Blade Diameter	305 mm (12")
Miter Angle	60° L / 60° R
Bevel Angle	48° L / 48° R
Max Cutting Capacity	90°: 107 x 363 mm (4-1/4" x 14-1/4") 45°: 107 x 255 mm (4-1/4" x 10")
No Load Speed (RPM)	3,200
Dimensions (L x W x H)	898x644x725 mm
Net weight	29.3 kg (64.6 lbs)
Power supply cord	2.5 m (8.2 ft.)



Carbide-Tipped Saw Blade, Vertical Vise, Hex Wrench, Triangular Rule, Dust Bag

LS1019L - Slide Compound Miter Saw

260 mm (10-1/4") 1,510 W DXT Slide Compound Miter Saw

LS1019L - Rs. 70,900



153

Continuous rating input	1,510W
Blade Diameter	260 mm (10-1/4")
Bevel Angle	48° L / 48° R
Miter Angle	60° L / 60° R
Max Cutting Capacity (Bevel/Miter)	90°/90°: 68 / 310 mm 90°/90°: 91 / 279 mm (3-5/8" / 11") 90°/45°LR: 68 / 218 mm 90°/45°LR: 91 / 197 mm (3-5/8" / 7-3/4")
No Load Speed (RPM)	3,200
Sound Pressure Level	91 dB(A)
Sound Power Level	101 dB(A)
Vibration Level	2.5 m/s ² or less
Dimensions (L x W x H)	805x644x660 mm
Net weight	(31-3/4"x25-3/8"x26") 26.3 kg (57.9 lbs.)
Power supply cord	2.5 m (8.2 ft.)



DXT
Deep and Exact Cutting Technology

TCT Saw Blade, Dust Bag, Triangular Rule, Vertical Vise, Hex Wrench

LS1221 - Compound Miter Saw

305 mm (12") 1,650 W Compound Miter Saw

LS1221 - Rs. 54,900



153

Continuous rating input	1,650W
Blade Diameter	305 mm (12")
Miter Angle	48° L / 48° R
Bevel Angle	45° L
Max Cutting Capacity	90°: 98 x 153 mm (3-7/8" x 6") 45°: 70 x 149 mm (2-3/4" x 5-7/8")
No Load Speed (RPM)	4,000
Dimensions (L x W x H)	674x610x607 mm
Net weight	(26-1/2"x24"x23-7/8") 16.8 kg (37.0 lbs)
Power supply cord	2.5 m (8.2 ft.)



Blade, Triangular Rule, Elbow, Socket Wrench, Dust Bag

DXT

Deep and Exact Cutting Technology

DEEP CUTTING

3-Stage reduction gear unit and Movable rear blade guard provide larger capacities of cutting Crown molding and Baseboard (Skirt board).

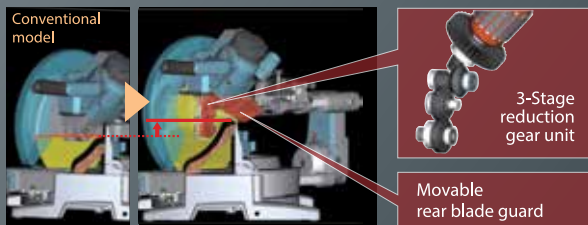

Capable of diagonal cutting up to 168mm (6-5/8") crown molding (LS1016/L)



Capable of vertical cutting up to 120mm (4-3/4") baseboard (LS1016/L)



EXACT CUTTING

Double sliding mechanism

Makita advantages obtained by using 4 short steel poles instead of 2 long poles are:

- Vibration-free, precise and exact cutting
- Compact tool design for jobsite portability



6 linear ball bearings are used to support the 4 poles for smooth and precise sliding cut.

Double sliding guide fence

The upper and the lower sections slide independently for added convenience; each upper fence slides outwards for bevel cut, and each lower fence slide inwards to securely hold small workpiece for precise and exact cutting.

Overall height 120mm (4-3/4")



LS1045 - Compound Miter Saw

260 mm (10-1/4") 1,650 W Compound Miter Saw

LS1045 - Rs. 36,100



Continuous rating input	1,650W
Blade Diameter	260 mm (10-1/4")
Miter Angle	45° L / 52° R
Bevel Angle	45° L
Max Cutting Capacity	90°: 90.5 x 95 mm (3-9/16" x 3-3/4") 45°: 90.5 x 67 mm (3-9/16" x 2-5/8")
No Load Speed (RPM)	4,600
Dimensions	530x476x532 mm
(L x W x H)	(20-7/8"x18-3/4"x21")
Net weight	19.1 kg (42.0 lbs)
Power supply cord	2.5 m (8.2 ft)



Carbide-Tipped Saw Blade, Socket Wrench, Dust Bag, Holders Set, Vise Assembly, Triangular Rule

LS1040 - Compound Miter Saw

260 mm (10-1/4") 1,650 W Compound Miter Saw

LS1040 - Rs. 29,000



Continuous rating input	1,650W
Blade Diameter	260 mm (10-1/4")
Miter Angle	45° L / 52° R
Bevel Angle	45° L
Max Cutting Capacity	90°: 90.5 x 95 mm (3-9/16" x 3-3/4") 45°: 90.5 x 67 mm (3-9/16" x 2-5/8")
No Load Speed (RPM)	4,600
Sound Pressure Level	93 dB(A)
Sound Power Level	106 dB(A)
Dimensions	530x476x532 mm
(L x W x H)	(20-7/8"x18-3/8"x21")
Net weight	12.4 kg (27.3 lbs)
Power supply cord	2.5 m (8.2 ft)



TCT. Saw Blade, Socket Wrench, Dust Bag, Holders 2, Vertical Vise, Triangular Rule.

LH1200FL - Table Top Miter Saw

Max. cutting width up to 200mm.

LH1200FL - Rs. 75,000



Continuous rating Input	1,650W
Max cutting capacity	at 0 degrees : 95x155mm (3-3/4"x6-1/8") at 45 degrees : 64x155mm (2-1/2"x6-1/8")
Blade diameter	305mm (12")
No load speed (rpm)	3,800
Dimensions (L x W x H)	610x535x692mm (24"x21"x27-1/4")
Net weight	20.7kg (45.6lbs)
Power supply cord	2.5m (8.2ft)



TCT saw blade, Vertical vise, Dust bag, Guide rule, Ring, Triangular rule, Push stick, Blade cover, Socket wrench, Holder set

2712 - Table Saw

315 mm (12-3/8") Table Saw

2712 - Rs. 45,000



Max Cutting Capacity	90°: 85 mm (3-3/8") 45°: 58 mm (2-1/4") 315 mm (12-3/8")
Blade Diameter	315 mm (12-3/8")
No Load Speed (RPM)	50 Hz: 2,950 60 Hz: 3,400
Bevel cutting capacity	0 - 45
Dimensions	1,670x700x810 mm (65-3/4"x27-1/2"x32")
Net weight	54 kg (118.9 lbs)
Power supply cord	3.0 m (9.8 ft)



Carbide-Tipped Saw Blade, Rip Fence, Miter Gauge, Wrenches, Push Stick, Ring

MLT100 - Table Saw

260 mm (10-1/4") 1,500 W Table Saw

MLT100 - Rs. 44,100



Continuous rating input	1,500W
Max Cutting Capacity	90°: 91 mm (3-9/16") 45°: 63 mm (2-1/2")
Blade Diameter	260 mm (10-1/4")
No Load Speed (RPM)	4,300
Dimensions	726x984x333 mm
(L x W x H)	(28-1/2"x38-3/4"x13-1/8")
Net weight	34.1 kg (75.2 lbs)
Power supply cord	2.5 m (8.2 ft)



TCT.Saw Blade, Rip Fence, Miter Gauge, Wrenches, Push Stick, Triangular Rule



HS7010 - Circular Saw

185 mm (7-1/4") / 190 mm (7-1/2") 1,600 W Circular Saw

HS7010 - Rs. 13,100



Continuous rating input	1,600W
Blade Diameter	185 / 190 mm (7-1/4" / 7-1/2")
Max Cutting Capacity	90°: 65 / 67 mm (2-9/16" / 2-5/8") 45°: 44 / 45 mm (1-3/4" / 1-3/4")
No Load Speed (RPM)	5,500
Dimensions	300x240x261 mm
(L x W x H)	(11-3/4"x9-1/2"x10-1/4")
Net weight	4.0 kg (8.9 lbs)
Power supply cord	2.5 m (8.2 ft)



TCT Saw Blade, Rip Fence (Guide Rule), Hex Wrench, Dust Nozzle

HS7600 - Circular Saw

185 mm (7-1/4") 1,200 W Circular Saw

HS7600 - Rs. 11,600



Continuous rating input	1,200W
Blade Diameter	185 mm (7-1/4")
Max Cutting Capacity	90°: 64 mm (2-1/2") 45°: 42 mm (1-5/8")
No Load Speed (RPM)	5,200
Vibration Level	Cutting Wood: 2.5 m/s ² or less
Sound Pressure Level	87 dB(A)
Sound Power Level	98 dB(A)
Dimensions	309x234x255 mm
(L x W x H)	(12-1/8"x9-1/4"x10")
Net weight	3.8 kg (8.3 lbs)
Power supply cord	2.5 m (8.2 ft)



Carbide-tipped saw blade, Hex wrench, Rip fence (guide rule)

N5900B - Circular Saw

235 mm (9-1/4") 2,000 W Circular Saw

N5900B - Rs. 14,700



153



Continuous rating input	2,000W
Blade Diameter	235 mm (9-1/4")
Max Cutting Capacity	90°: 85 mm (3-3/8") 45°: 60 mm (2-3/8") 50°: 53 mm (2-1/16")
No Load Speed (RPM)	4,100
Overall Length	380 mm (15")
Net weight	6.8 kg (14.8 lbs)
Power supply cord	2.5 m (8.2 ft)



T.C.T. Saw Blade 235mm, Guide Rule, Wrench 13

HS0600 - Circular Saw

260 mm (10-1/4") / 270 mm (10-5/8")
2,000 W Circular Saw

HS0600 - Rs. 27,900



153



Continuous rating input	260/270 mm (10-1/4" / 10-5/8")
Blade Diameter	90°: 97 / 101 mm (3-13/16" / 4")
Max Cutting Capacity	45°: 68 / 71 mm (2-11/16" / 2-13/16") 50°: 61 / 63 mm (2-3/8" / 2-1/2")
No Load Speed (RPM)	4,300
Vibration Level	Cutting Wood: 2.5 m/s ² or less
Sound Pressure Level	94 dB(A)
Sound Power Level	105 dB(A)
Dimensions (L x W x H)	418x273x324 mm (16-1/2"x10-3/4"x12-3/4")
Net weight	6.9 kg (15.2 lbs)
Power supply cord	2.5 m (8.2 ft)



TCT Saw Blade, Dust Nozzle (country-specific), Rip Fence (Guide Rule), Hex Wrench, Wrench holder

5402NA - Circular Saw

415 mm (16-5/16") 1,650 W Circular Saw,
Electric Brake

5402NA - Rs. 70,000



203



Continuous rating input	1,650W
Blade Diameter	415 mm (16-5/16")
Max Cutting Capacity	90°: 158 mm (6-1/4") 45°: 106 mm (4-3/16")
No Load Speed (RPM)	2,200
Overall Length	616 mm (24-1/4")
Net weight	12.5 kg (27.6 lbs)
Power supply cord	5.0 m (16.4 ft)



Carbide-tipped saw blade, Hex wrench, Rip fence (guide rule)

SP6000 - Plunge Cut Circular Saw

165 mm (6-1/2") 1,300 W Plunge Cut
Circular Saw

SP6000 - Rs. 40,000



303



Continuous rating input	1,300W
Blade Diameter	165 mm (6-1/2")
Max Cutting Capacity	90°: 56 mm (2-3/16") 45°: 40 mm (1-9/16") 48°: 38 mm (1-1/2")
No Load Speed (RPM)	2,000 - 5,800
Dimensions (L x W x H)	341x225x250 mm (13-3/8"x8-7/8"x9-7/8")
Net weight	4.1 kg (9 lbs)
Power supply cord	2.5 m (8.2 ft)



Carbide-tipped saw blade, Hex wrench, Guide rule

4350CT - Jig Saw

720 W Top Handle Jig Saw, 3 Orbital Settings
Plus Straight Cutting

4350CT - Rs. 19,300



419



Continuous rating input	720W
Capacity	Wood: 135 mm (5-5/16") Steel: 10 mm (3/8")
Length of Stroke	26 mm (1")
Strokes Per Minute (SPM)	800 - 2,800
Dimensions (L x W x H)	236x73x207 mm (9-1/4"x2-7/8"x8-1/8")
Net weight	2.7 kg (5.8 lbs)
Power supply cord	2.5 m (8.2 ft)



Blade Set (No. B-10, BR-13, B-22; 2 each), Hex Wrench, Cover Plate, Anti-Splintering Device

JV0600K - Jig Saw

650 W Top Handle Jig Saw, 3 Orbital Settings
Plus Straight Cutting

JV0600K - Rs. 12,600



64



Continuous rating input	650W
Capacity	Wood: 90 mm (3-1/2") Steel: 10 mm (3/8")
Length of Stroke	23 mm (7/8")
Strokes Per Minute (SPM)	500 - 3,100
Dimensions (L x W x H)	236x77x199 mm (9-1/4"x3"x7-7/8")
Net weight	2.4 kg (5.3 lbs)
Power supply cord	2.5 m (8.2 ft)



Jig Saw Blade, Hex Wrench

4327 - Jig Saw

450 W Top Handle Jig Saw

4327 - Rs. 6,800



64



Continuous rating input	450W
Capacity	Wood: 65 mm (2-9/16") Steel: 6 mm (1/4")
Length of Stroke	18 mm (11/16")
Strokes Per Minute (SPM)	500 - 3,100
Dimensions (L x W x H)	224x77x197 mm (8-7/8"x3"x7-3/4")
Net weight	1.9 kg (4.2 lbs)
Power supply cord	2.0 m (6.6 ft)



Jig Saw Blade, Hex Wrench

LB1200F - Band Saw

305 mm (12") 900 W Band Saw

LB1200F - Rs. 75,600



Continuous rating input	900W
Capacity	Thickness of cut: 165 mm (6-1/2") Throat: 305 mm (12")
Blade speed	High: (50 Hz) 800 (60 Hz) 1,000 m (150 Hz) 2,624 (60 Hz) 3,280 ft / min Low: (50 Hz) 400 (60 Hz) 500 m (150 Hz) 1,312 (60 Hz) 1,640 ft / min
Dimensions (L x W x H)	615x775x1,600 mm (24-1/4"x30-1/2"x63")
Net weight	82 kg (181.2 lbs)
Power supply cord	2.5 m (8.2 ft)



Band saw blades, Rip fence, Angle rule, Push stick, Nozzle 93, Hex wrench

Planing / Routering



1911B - Power Planer

110 mm (4-3/8") 840 W Power Planer

1911B - Rs. 29,500



106



Continuous rating input	840W
Planing Width	110 mm (4-3/8")
Planing Depth	2 mm (1/16")
No Load Speed (RPM)	16,000
Overall Length	355 mm (14")
Net weight	4.1 kg (9.1 lbs)
Power supply cord	5.0 m (16.4 ft)



Sharpening Holder Assembly, Blade Gauge Assembly, Socket Wrench, Planer Blade

2012NB - Planer

304 mm (12") 1,650 W Planer

2012NB - Rs. 62,700



153



Continuous rating input	1,650W
Cutting Width	304 mm (12")
Cutting depth	Cutting width 0-150 mm : 3 mm (1/8")
	Cutting width 150-240 mm : 1.5 mm (1/16")
Feed rate/min.	8.5 m (27.9 ft)
Table Size (W x L)	304 x 771 mm (12" x 30-3/8")
No Load Speed (RPM)	8,500
Dimensions (L x W x H)	483x771x401 mm (19"x30-3/8"x15-13/16")
Net weight	27.1 - 27.6 kg (59.7 - 60.9 lbs)
Power supply cord	2.5 m (8.2 ft)



Socket Wrench, Hex Wrench, Magnetic Holders 2

PJ7000 - Plate Joiner

701 W Plate Joiner

PJ7000 - Rs. 23,000



459



Continuous rating input	701W
Blade Diameter	100 mm (4")
No Load Speed (RPM)	11,000
Dimensions (L x W x H)	302x139x145 mm (11-7/8"x5-1/2"x5-3/4")
Net weight	2.8 kg (6.2 lbs)
Power supply cord	2.5 m (8.2 ft)



Cutter Blade, Angle Guide, Dust Bag, Set Plate, Lock Nut Wrench

RT0700C - Trimmer

6 mm (1/4"), 8 mm (3/8")
710 W Variable Speed Trimmer

RT0700C - Rs. 11,500



411



Continuous rating input	710W
Collet Capacity	6 mm (1/4"), 8 mm (3/8")
No Load Speed (RPM)	10,000 - 30,000
Vibration Level	Rotation without Load: 2.5 m/s ² or less Cutting Grooves in MDF: 3.5 m/s ²
Sound Pressure Level	82 dB(A)
Sound Power Level	93 dB(A)
Dimensions (L x W x H)	89x89x200 mm (3-1/2"x3-1/2"x7-7/8")
Net weight	1.8 - 2.7 kg (3.9 - 6.0 lbs)
Power supply cord	2.5 m (8.2 ft)



Trimmer Base Assembly, Straight Guide, Collet Cone (2 pcs), Wrench (2 pcs)

3709 - Trimmer

6 mm (1/4") 530 W Fixed Base Trimmer

3709 - Rs. 7,300



411



Continuous rating input	530W
Collet Capacity	6 mm or 1/4"
No Load Speed (RPM)	30,000
Vibration Level	Rotation without Load: 2.5 m/s ² or less 80 dB(A)
Sound Pressure Level	82x90x199 mm (3-1/4"x3-1/2"x7-7/8")
Dimensions (L x W x H)	82x90x199 mm (3-1/4"x3-1/2"x7-7/8")
Net weight	1.5 kg (3.3 lbs)
Power supply cord	2.5 m (8.2 ft)



Trimmer Guide Assembly, Straight Guide Assembly, Templet Guide, Straight Bit, Wrench (2 pcs), Collet Cone (6mm or 1/4"), Chip Deflector

RP2301FC - Router (Plunge type)

12 mm (1/2") 2,100 W Variable Speed Plunge Router with Electric Brake, Soft Start

RP2301FC - Rs. 40,000

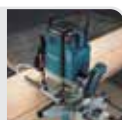

203



Continuous rating input	2,100W
Collet Capacity	12 mm or 1/2"
Plunge Capacity	0 - 70 mm (0 - 2-3/4")
No Load Speed (RPM)	9,000 - 22,000
Vibration Level	Cutting Grooves in MDF: 4.5 m/s ²
Sound Pressure Level	87 dB(A)
Sound Power Level	98 dB(A)
Dimensions (L x W x H)	155x294x312 mm (6-1/8"x11-5/8"x12-1/4")
Net weight	6.1 kg (13.5 lbs)
Power supply cord	4.0 m (13.1 ft)



Straight guide, Collet cone, Wrench, Screw M6x135

RP1800 - Router (Plunge type)

12 mm (1/2") 1,850 W Plunge Router

RP1800 - Rs. 31,600



203



Continuous rating input	1,850W
Collet Capacity	12 mm or 1/2"
Plunge Capacity	0 - 70 mm (0 - 2-3/4")
Base dia.	170 mm (6-11/16")
No Load Speed (RPM)	22,000
Vibration Level	Cutting Grooves in MDF: 4.0 m/s ²
Sound Pressure Level	86 dB(A)
Sound Power Level	97 dB(A)
Dimensions (L x W x H)	155x294x312 mm (6-1/8"x11-5/8"x12-1/4")
Net weight	6 kg (13.2 lbs)
Power supply cord	4.0 m (13.1 ft)



Straight guide, Collet cone, Wrench, Screw M6x135

7104L - Chain Mortiser

1,140 W Chain Mortiser **7104L - Rs. 1,50,000**



new



Continuous rating input	1,140W
Capacity	Max hole width : 130 mm (5-1/8") Max hole depth : 155 mm (6-1/8")
No Load Speed (RPM)	3,200
Dimensions (L x W x H)	512x298x513 mm (20-3/16"x11-3/4"x20-1/4")
Net weight	17.8 - 18.2 kg (39.4 - 40.1 lbs.)
Power supply cord	5.0 m (16.4 ft)

Cutter Chain, Sharpening Holder Assembly, Oil supply 100ml, Wrench

Dust Extraction / Others



Corded

VC2510LX1 - Vacuum Cleaner (Wet & Dry)

Complying with dust class L. **VC2510LX1 - Rs. 37,500**



GYUPPA!

Continuous rating Input	1,050W
Max. peak air flow	2.0m ³ / min
Max. sealed suction (water column)	22.0kPa (2,240mmH2O)
Tank capacity	Dust : 25L Water : 14L
Dimensions (L x W x H)	432x416x451 mm (17"x16-3/8"x17-3/4")
Net Weight	10.5kg



Hose Complete 28-3.5 (with Front Cuffs 38), Holder 10-33, Front Cuffs 22, Front Cuffs 24, Plastic Dust Bag Set

VC3210LX1 - Vacuum Cleaner (Wet & Dry)

Complying with dust class L. **VC3210LX1 - Rs. 43,750**



GYUPPA!

Continuous rating Input	1,050W
Max. peak air flow	2.0m ³ / min
Max. sealed suction (water column)	22.0kPa (2,240mmH2O)
Tank capacity	Dust : 32L Water : 27L
Dimensions (L x W x H)	552x398x685mm (21-3/4"x15-5/8"x27")
Net Weight	14.5kg



Hose Complete 28-3.5 (with Front Cuffs 38), Holder 10-33, Front Cuffs 22, Front Cuffs 24, Plastic Dust Bag Set

Automatic self-cleaning filter

VC1310L, VC2510L, VC3210L

obtained by Triple filter structure composed of:
Powder filter + Damper + Prefilter

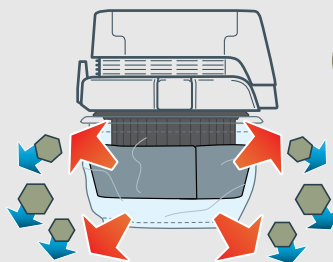
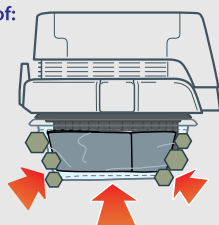

When the power is switched on, Prefilter collapses into itself to compress Damper, and fits closely over Damper and Powder filter.

Allows for:
Constantly high suction power
Easy filter cleaning simply by tapping dust off of Prefilter
Quiet cleaning because Damper and Prefilter make no noise

When the power is switched off, Damper expands back to its original size and shakes off dust from Prefilter automatically with its expanding power.

HG5030K - Heat Gun

1,600 W Heat Gun **HG5030K - Rs. 5,200**



Continuous rating input	1,600W
Air temperature (°C)	High / Low: 500 / 350
Air Flow	High / Low: 500 / 300 L/min
Dimensions (L x W x H)	233x80x208 mm (9-1/8"x3-1/8"x8-3/16")
Net weight	0.58 kg (1.3 lbs)
Power supply cord	2.0 m (6.6 ft.)



HG6003 - Heat Gun

Durable and powerful heat-gun with 2-temperature settings **HG6003 - Rs. 5,200**



Continuous rating input	1,800W
Air temperature (degrees C)	600
Air flow	Hi (220-240V): 550 L/min Lo (220-240V): 280 L/min Hi (110-127V): 400 L/min Lo (110-127V): 200 L/min
Temperature setting	2 settings
Dimensions (L x W x H)	262x80x190mm (10-3/8"x3-1/8"x7-1/2")
Net weight	0.92kg (2.0lbs)



Reflector nozzle (Nozzle B), Concentrator nozzle (Nozzle D)

HG6030K - Heat Gun

1,800 W Heat Gun

HG6030K - Rs. 6,500



new



Continuous rating input	1,800W
Air Temperature (°C) / Flow (L/min)	Switch 1: 50 / 250 Switch 2: 300 / 250 Switch 3: 600 / 500
Dimensions (L x W x H)	233x80x208 mm (9-1/8"x3-1/8"x8-3/16")
Net weight	0.57 kg (1.3 lbs.)
Power supply cord	2.0 m (6.6 ft)



Glass protection nozzle, Reflector nozzle, Reduction nozzle, Wide slot nozzle, Scraper

HG6500 - Heat Gun

2,000 W Heat Gun

HG6500 - Rs. 8,400



Continuous rating input	2,000W
Air temperature (°C)	70-650
Air Flow	Hi (220-240 V): 550 L/min Lo (220-240 V): 280 L/min Hi (110-127 V): 400 L/min Lo (110-127 V): 200 L/min
Dimensions (L x W x H)	262x80x190 mm (10-3/8"x3-1/8"x7-1/2")
Net weight	1.2 - 1.4 kg (2.5 - 3.2 lbs)



Reflector nozzle (Nozzle B), Concentrator nozzle (Nozzle D), Nozzle A, Nozzle C, Fishtail spreader A, Fishtail spreader B, Fishtail spreader C, Fisher spread handle, Stripper

UB1102 - Blower

High output air volume.

UB1102 - Rs. 6,485



Continuous rating Input	600W
Air volume	4.1 m ³ /min
Air pressure	5.7 kPa (580 mm H ₂ O)
No load speed (rpm)	16,000
Dimensions (L x W x H)	479x185x178 mm (18-7/8"x7-1/4"x7")
Net weight	2.0 kg (4.3 lbs)
Power supply cord	2.5 m (8.2 ft)



Nozzle Assembly, Dust Bag (capacity of 2L) (for some countries)

SK104Z - Cross Line Laser

Self-Leveling Horizontal/Vertical Cross Line laser

SK104Z - Rs. 20,700



Measuring range	Up to: 15 m
Measuring range with detector	Up to: 60 m
Leveling accuracy	±3 mm / 10 m
Self-leveling range	4±1°
Laser fan angle	Horizontal: 180°
Number of laser points	Vertical: 180°
Number of laser lines	42
Laser type	Laser class 2: 635 nm
Operating temperature	-10 - 40 °C
Storage temperature	-25 - 70 °C
Tripod thread	1/4"
Protection class	IP54
Net weight	0.53 kg (1.17 lbs)

Wall Mount Bracket, Target Plate, AA Battery, Pouch with strap

LD030P - Laser Distance Measure

30 m Laser Distance Measure

LD030P - Rs. 9,400



Measuring range	0.2-30 m
Operating temperature	0 - 40 °C
Storage temperature	-25 - 70 °C
Typical measuring tolerance	±2.0 mm / 10 m
Max measuring tolerance	±3.0 mm / 10 m
Diameter of laser point	6 mm / 10 m
Laser type	Laser class 2: 635 nm
Dimensions (H x D x W)	117x53x25 mm (4.5"x2.14"x1")
Net weight	0.1 kg (0.22 lbs)

AAA Alkaline Dry Battery 1.5V x2, Pouch



Pneumatic Tool



AT1216AZ - Pneumatic Stapler

Handy and lightweight stapler.

AT1216AZ - Rs. 8,600



Capacity	Length : 6 - 16 mm (1/4" - 5/8")
	Gauge : 21 Ga
Magazine capacity	100 pcs
Operating pressure	60 - 100 PSI
Dimensions (L x W x H)	220x150x45 mm
Net weight	0.9 kg (1.98 lbs)

AN560 - Pneumatic Pallet Coil Nailer

50 mm (2") Pneumatic Pallet Coil Nailer

AN560 - Rs. 45,000



Capacity	Length: 27-50 mm (1-1/16" - 2") Wire: 2.1 mm (3/32")
Magazine Capacity	350-400
Operating Pressure	0.49-0.78 MPa (70-115 PSI)
Dimensions (L x W x H)	300x127x280 mm (11-3/4"x5"x11")
Net weight	2.1 kg (4.6 lbs)



Oil supply, Safety goggles, Hex wrench

AT638A - Narrow Crown Stapler

18 GA 38 mm (1-1/2") Narrow Crown Stapler

AT638A - Rs. 11,600



Capacity	Length: 15-38 mm (5/8" - 1-1/2") Gauge: 18 Ga Width: 5.7 mm
Operating Pressure	0.39-0.78 MPa (60 - 115 PSI)
Magazine Capacity	100
Dimensions (L x W x H)	247x62x246 mm (9-3/4"x2-7/16"x9-11/16")
Net weight	1.2 kg (2.7 lbs)



Safety Goggles, Oil supply (country-specific), Nose Adapter, Hex Wrench

AF353 - Pneumatic Pin Nailer

23 GA 35 mm (1-3/8") Pneumatic Pin Nailer, Air Duster

AF353 - Rs. 12,300

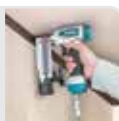

Capacity	Length: 15-35 mm (5/8" - 1-3/8") Gauge: 23 Ga
Operating Pressure	0.45-0.69 MPa (65 - 100 PSI)
Magazine Capacity	130
Dimensions (L x W x H)	208x66x191 mm (8-3/16"x2-5/8"x7-1/2")
Net weight	0.9 kg (2 lbs)



Safety Goggles, Oil supply (country-specific), Nose Adapter, Hex Wrench

AF505N - Pneumatic Brad Nailer

Handy and lightweight brad nailer with slim nose.

AF505N - Rs. 10,200



Capacity	Length: 15-50mm (5/8" - 2") Gauge: 18Ga
Magazine capacity	100pcs
Operating pressure	0.39 - 0.78MPa (60 - 115PSI)
Dimensions (L x W x H)	260x64x237mm (10-1/4"x2-1/2"x9-3/8")
Net weight	1.4kg (3.1lbs)



Oil supply, Safety goggles

AF635 - Pneumatic Finish Nailer

15 GA 64 mm (2-1/2") Pneumatic Finish Nailer, Air Duster

AF635 - Rs. 16,800



Capacity	Length: 32-64 mm (1-1/4" - 2-1/2") Gauge: 15 Ga
Operating Pressure	0.49 - 0.83 MPa (70 - 120 PSI)
Magazine Capacity	100
Dimensions (L x W x H)	339x100x309 mm (13-3/8"x3-15/16"x12-1/8")
Net weight	1.8 kg (4 lbs)



Safety Goggles, Oil supply (country-specific), Nose Adapter

AF601 - Pneumatic Finish Nailer

16 GA 64 mm (2-1/2") Pneumatic Finish Nailer, Air Duster

AF601 - Rs. 16,500



Capacity	Length: 25-64 mm (1" - 2-1/2") Gauge: 16 Ga
Operating Pressure	0.49-0.83 MPa (70 - 120 PSI)
Magazine Capacity	100
Dimensions (L x W x H)	304x95x297 mm (12"x3-3/4"x11-3/4")
Net weight	1.7 kg (3.8 lbs)



Safety Goggles, Oil supply (country-specific), Nose Adapter

More powerful cutting in stone masonry, tile and concrete.

MT410 - Cutter

More Powerful cutting in stone masonry, tile and concrete

MT410 - Rs. 5,300



Continuous rating Input	1,200W
Capacity	Max. cutting: 32mm (1-1/4")
Blade diameter	110mm (4-3/8")
No load speed (rpm)	13,000
Dimensions (L x W x H)	226x211x163mm (8-7/8"x8-5/16"x6-3/8")
Net Weight	3.0kg (6.6lbs)
Power supply cord	2.0m (6.6ft)



Wrench, Hex Wrench (Tool does not come with diamond wheel.)

maktec
by **Makita**

PRODUCTS

OUTDOOR POWER EQUIPMENT



A wide variety of Lithium-ion Garden Tools



Reliable & Environment Friendly Makita 4-Stroke Engine Series



What is Makita 4-Stroke Engine?

Makita newly designed 4-Stroke Engines provide the following advantages compared with 2-stroke of equivalent size.

1. High Performance, Compact and Light Weight Design
2. Clean Exhaust Emissions
3. Low Running Cost
4. Easy Maintenance
5. Low Noise

1. High Performance, Compact and Light Weight Design

Makita 4-Stroke Engine delivers high torque and horsepower. Max. Torque and horsepower of Makita 4-Stroke Engine are almost the same as those of an equivalent 2-Stroke engine as shown below in the chart.

Compared with the conventional 4-Stroke Engines, Makita 4-Stroke Engine produces approximately 20 to 30 % more power thanks to its high combustion efficiency and new developments such as compact spark plug

Additionally, by employing a unique lubrication system, it has obtained the smallest in class exterior physical dimensions among the 4-Stroke Engines available in the market today. And it is also lightest in class in weight by using magnesium alloy diecast for Clutch case, etc

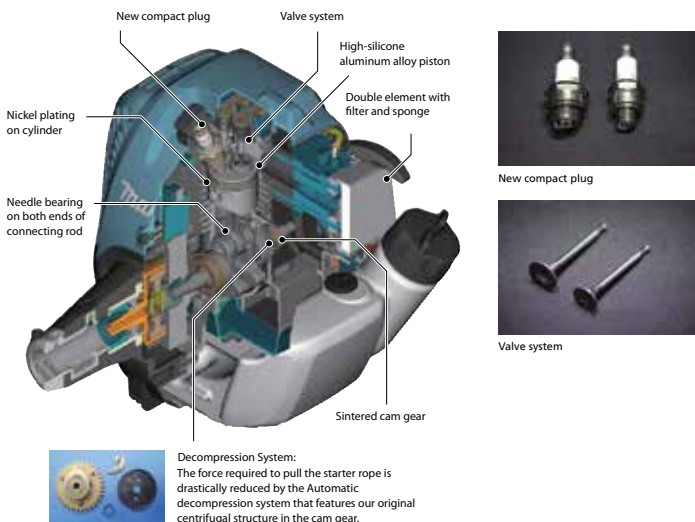

Decompression System:
The force required to pull the starter rope is drastically reduced by the Automatic decompression system that features our original centrifugal structure in the cam gear.

35mL Class		25mL Class		
	33.5mL 4-Stroke Engine	24.5mL 4-Stroke Engine	25.4mL 4-Stroke Engine	24.5mL 2-Stroke Engine
Max Power (PS-rpm)	1.45 / 7000	0.97 / 7000	1.1 / 7000	0.98 / 7000
	1.3 / 7000			

Patented Unique Lubrication System enables to use 4-Stroke Engine in Semi Multi-position.

Employing this system enables to use 24.5mL and 33.5mL Brushcutters on any slope such as ditch slopes, river banks or mountain woods.

The natural pressure changes in the crankcase caused by the piston movement in the cylinder are harnessed to pump the oil throughout the engine.

Oil is pumped from a reservoir in the base of the engine through a network of one-way valves for reliable lubrication and long service life without the need to keep the engine level.

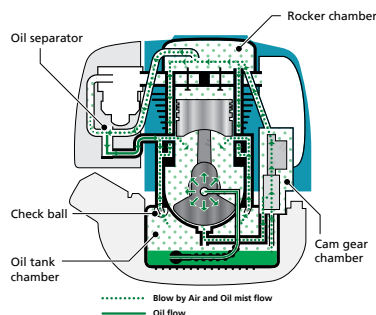

2. Clean Exhaust Emissions

Compared with an equivalent 2-Stroke Engine, exhaust emission is drastically reduced to comply with strict regulations in the world, including CARB Tier 3 (California, USA), EPA Phase 2 (USA) and EU Stage 2 (Europe).

As shown in the table to right, the exhaust emission level of Makita 4-Stroke Engine is well below the standard level of the regulations.

	24.5mL	25.4mL	33.5mL	43.0mL	75.6mL
Certification/ Standard level of Emission Gas: HC+Nox (g/kw-hr)	24.5mL < 50mL CARB/ EPA/ EU "50"	25.4mL < 50mL CARB/ EPA/ EU "50"	33.5mL < 50mL CARB/ EPA/ EU "50"	43mL < 50mL CARB/ EPA/ EU "50"	75.6mL ≥ 50mL CARB/ EPA/ EU "72"
Certificated level of Makita 4-Stroke engine: HC+Nox (g/kw-hr)	27	25	21	17	16
Certificated level of 2-Stroke engine: HC+Nox (g/kw-hr)	240 (21mL)	205 (24.5mL)	201 (30.5mL)	205 (40.2mL)	204 (48.6mL)

3. Low Running Cost

From our comparison test between Makita 24.5mL 4-Stroke Petrol Brushcutter and an equivalent 2-Stroke Petrol Brushcutter, the superiority of Makita 4-Stroke Engine over 2-Stroke Engine in its class has been proved both in fuel consumption and total cost as shown in the charts below.

Fuel Consumption 40% better

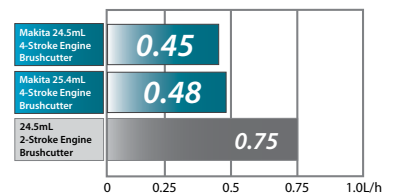

Total Cost 60% better (200H of Operation)

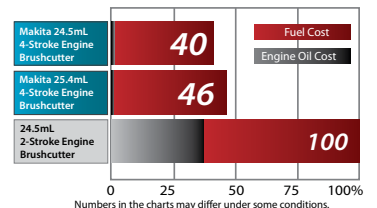

Numbers in the charts may differ under some conditions.

4. Easy Maintenance

Makita 4-Stroke Engine uses straight unleaded gasoline. Operator can, therefore, skip the following preparation and maintenance required when using 2-Stroke or 4-mix engine that runs on gas/oil mixture:

- /// Mixing gasoline and oil before operation
- /// Removing fuel from tank after operation, then sweeping dust from oil filling port*

*Removing fuel is recommended for 4-Stroke engine at the end of season.

5. Low Noise

Low noise level allows to operate without disturbing others even in quiet places such as parks or residential areas.



Brush Cutter



EM2500U - Petrol Brushcutter

Equipped with catalytic muffler to comply with European exhaust emission regulations; EPA Phase 3 and EU Stage 3.

EM2500U - Rs. 22,100



Displacement	24.5mL
Engine power	0.73kW / 1.0PS
Fuel tank	0.4L
Spindle size	M8 x 1.25LH
Dimensions (L x W x H)	1,770x620x410mm
Net weight	4.5kg (9.9lbs)



Nylon cutting head, Star blade

EM3400U - Petrol Brushcutter

Equipped with catalytic muffler to comply with European exhaust emission regulations; EPA Phase 3 and EU Stage 3.

EM3400U - Rs. 27,500



Displacement	34.0mL
Engine power	1.15kW / 1.6PS
Fuel tank	0.75L
Spindle size	M10 x 1.25LH
Sound pressure level	95dB(A)
Sound power level	109.1dB(A)
Vibration level Left handle	4.4m/s ²
Vibration level Right handle	4.1m/s ²
Dimensions (L x W x H)	1,815x650x435mm
Net weight	6.4kg (14.1lbs)



Nylon cutting head, 2 teeth blade

Net weight : without guard, cutting tool, shoulder harness and fuel

RBC411U - Petrol Brushcutter

Robust Makita brushcutter ideal for professional brush-cutting.

RBC411U - Rs. 41,500



Displacement	40.2mL
Engine power	1.40kW / 2.0PS
Fuel tank	1.1L
Spindle size	M10 x 1.25LH
Dimensions (L x W x H)	1,710x670x430mm
Net weight	7.3kg (16.1lbs)



2 teeth blade, Protector, Harness, Tool set, Trimmer head

Net weight : without blade, harness and fuel

UR3501 - Electric Grass Trimmer

Cost-effective and lightweight

UR3501 - Rs. 13,000



Continuous rating Input	1,000W
Cutting width	350mm (13-3/4")
No load speed (rpm)	7,500
Dimensions (L x W x H)	1,550x410x500mm
Net weight	4.3kg (9.6lbs)
Power supply cord	0.35m (1.2ft)



Nylon cutting head, Single harness, Socket wrench 14-19

YA00000504

DUX60 - Cordless Multi Function Power Head

18V X2 LXT BL AFT Cordless Multi Function Power Head

DUX60ZM3 - Rs. 40,000
DUX60Z - Rs. 28,000



Li-ion Ah	4.0	2.0	1.5
No Load Speed (RPM)	High: 0 - 9,700		
	Medium: 0 - 8,200		
	Low: 0 - 5,700		
Dimensions (L x W x H)	1,011x320x216 mm		
Net weight	(39-3/4"x12-5/8"x8-1/2")		
	4.1 - 8.7 kg (8.9 - 19.2 lbs)		



Harness, Safety Goggles, Hex Wrench, Accessory Bag, Tool bag

DUR365U - Cordless Grass Trimmer

High power and more work amount, powered by two 18V Li-ion batteries in series

DUR365URM2 - Rs. 59,000
DUR365UZ - Rs. 28,000



Li-ion Ah	5.0	4.0	3.0	1.5
No load speed (rpm)	3,500 / 5,500 / 6,500			
Spindle size	M10 x 1.25LH			
Sound pressure level	75dB(A)			
Sound power level	86dB(A)			
Vibration level Left handle	1.1m/s ²			
Vibration level Right handle	0.9m/s ²			
Dimensions (L x W x H)	1,823x610x460mm			
Max output	550W			
Net weight	4.7kg (10.5lbs)			



Battery cover, Safety goggles, Accessory bag, Hex wrench 4, Box driver, Blade cover, Shoulder belt

DUR187 - Cordless Grass Trimmer

18V LXT BL ADT Cordless Grass Trimmer, Loop Handle

DUR187LRF - Rs. 49,000

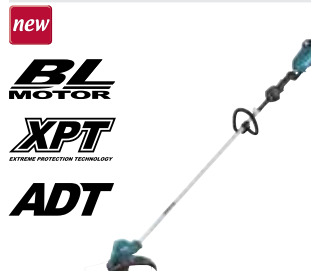

Li-ion Ah	4.0	2.0	1.5
Cutting Width	Nylon Cutting Head: 300 mm (11-3/4")		
	Plastic Blade: 255 mm (10")		
No Load Speed (RPM)	High / Medium / Low / ADT Mode: 6,000 / 5,000 / 4,000 / 4,000 - 6,000		
Spindle Size	M8 x 1.25 LH		
Sound Pressure Level	Nylon Cutting Head: 74 dB(A)		
Sound Power Level	Nylon Cutting Head: 84 dB(A)		
Sound Pressure Level	Plastic Blade: 79 dB(A)		
Sound Power Level	Plastic Blade: 88 dB(A)		
Vibration Level	Front / Rear: 2.5 / 2.5 m/s ² or less		
Dimensions (L x W x H)	1,791x258x232 mm		
Max Run Time (min)	Nylon Cutting Head, BL1860B: 168		
	Plastic Blade, BL1860B: 219		
Net weight	3.4 - 3.7 kg (7.5 - 8.2 lbs)		



Safety Goggles, Shoulder Harness, Nylon Cutting Head, Plastic Blade, Accessory Bag, Hex Wrench

DUR182 - Cordless Grass Trimmer

18V LXT BL Brushless Cordless Grass Trimmer,
Loop Handle

DUR182LRF - Rs. 39,000
DUR182LZ - Rs. 27,500



Li-ion	AH	5.0	4.0	3.0	1.5
No load speed (rpm)		3,500-6,000			
Spindle size		M8 x 1.25LH			
Sound pressure level		79dB(A)			
Sound power level		90dB(A)			
Vibration level Left handle		2.5m/s ²			
Vibration level Right handle		2.5m/s ²			
Dimensions (L x W x H)		1,843x287x253mm			
Net Weight		3.9kg (8.6lbs)			

Battery cartridge, Single harness, Nylon cutting head, Wrenches, Safety goggles

UR100D - Cordless Grass Trimmer

12V max CXT Li-Ion Cordless Grass Trimmer

UR100DWAE - Rs. 22,500
UR100DWAEX - Rs. 22,500
UR100DZ - Rs. 12,000
UR100DZX - Rs. 12,000



Li-ion	AH	2.6	2.2		
Cutting Width		Nylon Cutting Head: 260 mm (10") Plastic Blade: 230 mm (9")			
No Load Speed (RPM)		10,000			
Spindle Size		M8 x 1.25 RH			
Max Output		130 W			
Dimensions (L x W x H)		835 - 1,185x267x210 - 315 mm			
Net weight		1.9 - 2.1 kg (4.3 - 4.6 lbs.)			

Safety Goggles, Shoulder Belt, Nylon Cutting Head, Nylon Cord, Plastic Blade, Accessory Bag, Hex Wrench

Lawn Mower



PLM4620N2 - Petrol Lawn Mower

46 cm (18-1/8") 150 mL 4-Stroke
2-in-1 Mower

PLM4620N2 - Rs. 49,100



Engine	B&S 625E R/S, 150 cc
Cutting width	460mm (18-1/8")
Cutting height	25, 31, 43, 56, 70mm (1, 1-1/4, 1-11/16, 2-3/16, 2-3/4")
No Load Speed (RPM)	2,800
Recommended mowing area up to	1,200m ²
Grass box capacity	60L
Dimensions (L x W x H)	800x540x400 mm (31-1/2"x21-1/4"x15-3/4")
Net weight	27.6 kg (60.9 lbs.)

ELM3711 - Electric Lawn Mower

Silent and without emission.

ELM3711 - Rs. 15,600



Continuous rating Input	1,300W
Cutting width	370mm (14-1/2")
Cutting height	20,40,55mm (13/16, 1-9/16, 2-3/16")
Recommended mowing area up to	500m ²
Grass box capacity	35L
Dimensions (L x W x H)	662x412x312mm (26"x16-1/2"x12-5/8")
Net weight	14.8kg (32.6lbs)



ELM4110 - Electric Lawn Mower

Premium class lawn mower with more functions for easy and powerful work.

ELM4110 - Rs. 28,500



Continuous rating Input	1,600W
Cutting width	410mm (16-1/8")
Cutting height	20, 32, 44, 60, 75mm (3/4, 1-1/4, 1-3/4, 2-3/8, 3")
Recommended mowing area up to	600m ²
Grass box capacity	50L
Dimensions (L x W x H)	760x500x410mm (30"x19-3/4"x16-1/8")
Net weight	25.8kg (56.9lbs)



ELM4613 - Electric Lawn Mower

Premium class lawn mower with more functions for easy and powerful work.

ELM4613 - Rs. 43,500



Continuous rating Input	1,800W
Cutting width	460mm (18-1/8")
Cutting height	20-75mm (13/16"-2-15/16")
Propelling speed	3.6km/h
Recommended mowing area up to	1,000m ²
Grass box capacity	60L
Dimensions (L x W x H)	825x540x415mm (32-1/2"x21-1/4"x16-3/8")
Net weight	32.5kg (71.6lbs)



DLM460 - Cordless Lawn Mower

18V X2 (36V) LXT BL Brushless Cordless 46 cm
(18-1/8") 3-in-1 Mower

DLM460PTZ - Rs. 98,000
DLM460Z - Rs. 65,000



Li-ion	AH	5.0	4.0	3.0	1.5
Blade Type		2 Tooth			
Hole Diameter		10.0 mm (3/8")			
Cutting Width		460 mm (18-1/8")			
Cutting Height		20 - 75 mm (13/16" - 2-5/16")			
Grass box capacity		60 L			
No Load Speed (RPM)		2,500 - 3,300			
Recommended mowing area w/ BL1860B x2:		800 - 1,600 m ²			
Actual mowing area on a single full battery charge w/ BL1860B x2:		800 m ²			
Continuous Use (min.)		w/ BL1860B: 21			
Wheel Size		Front / Rear: 180 / 205 mm (7 / 8")			
Max Output		1,450 W			
Dimensions (L x W x H)		1,319-1,518x532x879-1,138 mm (52"-59-3/4"x21"x34-1/2"-44-3/4")			
Net weight		25.3 - 27.6 kg (55.8 - 60.8 lbs.)			



Blade, Socket Wrench



Photo: EA3501S

Environment-friendly 2-stroke engine

with Catalytic muffler to comply with all known exhaust emission regulations.

(EA3501S, EA3500S, EA3201S, EA3200S)



EA3501S
EA3503S
EA3201S
EA3203S

Tool-less tension adjustment of saw chain.



EA3500S
EA3502S
EA3200S
EA3202S

Two retaining nuts for reliable bar fastening.

Lateral chain tensioner provides easy operator access.



Easy start-up with spring-assisted recoil starter



Touch & Stop switch system

keeps spark plug from getting wet.



Big tank cap with Z-shaped hook

for easy operation



Solid heat protector between housing and exhaust muffler



Primer pump

for easy start-up



Outside sprocket

for easy maintenance



Adjustable metal oil pump

for better chain blade lubrication



Large metal spike bar

holds the machine steady for increased productivity.

Chain Saw



EA3110T25B - Petrol Chain Saw

25 / 30 cm (10" / 12") 30.1 mL
2-Stroke Chain Saw

EA3110T25B - Rs. 34,100



Saw chain	Pitch: 3/8" Gauge: 1.3mm (.050")
Displacement	30.1mL
Engine power	1.0kW / 1.4PS
Fuel tank	0.24L
Chain oil tank	0.18L
Vibration level Front handle	3.3m/s ²
Vibration level Rear handle	3.7m/s ²
Dimensions (L x W x H)	259x236x217mm (10-1/4"x9-1/4"x8-1/2")
Power head weight	3.2kg (7.0lbs)



Guide bar, Saw chain, Guide bar cover, Socket wrench + Screwdriver, - Screwdriver

EA3502S40B - Petrol Chain Saw

More powerful Entry class chain saw for home and garden.

EA3502S40B - Rs. 36,200



Chain blade	Pitch: 3/8" Gauge: 1.1 mm (0.043") / 1.3 mm (0.050")
Displacement	35.0mL
Engine power	1.7kW / 2.4PS
Fuel tank	0.4L
Chain oil tank	0.29L
Sound pressure level	101.8dB(A)
Sound power level	111.8dB(A)
Vibration level Front handle	4.9m/s ²
Vibration level Rear handle	5.0m/s ²
Dimensions (L x W x H)	415x247x273mm (16-3/8"x9-3/4"x10-3/4")
Power head weight	4.4kg (9.7lbs)



Saw chain, Guide bar (carving bar or sprocket nose bar), Guide bar cover, Socket wrench, - Screwdriver

EA4301F45B - Petrol Chain Saw

High power and low fuel consumption

EA4301F45B - Rs. 39,100



Chain blade	Pitch: 3/8" Gauge: 1.3mm (.050")
Displacement	42.4mL
Engine power	2.2kW / 3.0PS
Fuel tank	0.48L
Chain oil tank	0.28L
Sound pressure level	100.8dB(A)
Sound power level	110dB(A)
Vibration level Front handle	3.6m/s ²
Vibration level Rear handle	3.2m/s ²
Dimensions (L x W x H)	416x248x279mm (16-3/8"x9-3/4"x11")
Power head weight	4.8kg (10.5lbs)



Guide Bar, Saw Chain, Guide Bar Cover, Socket Wrench, Screwdriver

EA6100P45E - Petrol Chain Saw

38 - 60 cm (15" - 23-5/8") 60.7 mL 2-Stroke Chain Saw, Stratified Scavenging

EA6100P45E - Rs. 93,300



Chain blade	Pitch: 3/8" Gauge: 1.5mm (.058")
Displacement	60.7mL
Engine power	3.4kW / 4.6PS
Fuel tank	0.8L
Chain oil tank	0.48L
Sound pressure level	105dB(A)
Sound power level	117dB(A)
Vibration level Front handle	5.0m/s ²
Vibration level Rear handle	4.0m/s ²
Dimensions (L x W x H)	435x243x312mm (17-1/8"x9-9/16"x12-1/4")
Power head weight	6.0kg (13.2lbs)



Guide Bar, Saw Chain, Guide Bar Cover, Socket Wrench, -Screwdriver

EA7300P45E - Petrol Chain Saw

Ergonomically designed down to micromillimeter for professionals. High performance engine.

EA7300P45E - Rs. 88,000



Chain blade	Pitch: 3/8" Gauge: 1.5mm (.058")
Displacement	73.0mL
Engine power	4.0kW / 5.4PS
Fuel tank	0.75L
Chain oil tank	0.42L
Sound pressure level	105.1dB(A)
Sound power level	115.3dB(A)
Vibration level Front handle	6.2m/s ²
Vibration level Rear handle	4.1m/s ²
Power head weight	6.3kg (13.8lbs)



Guide Bar, Saw Chain, Guide Bar Cover, Socket Wrench, -Screwdriver

EA7900P45E - Petrol Chain Saw

Ergonomically designed down to micromillimeter for professionals. High performance engine.

EA7900P45E - Rs. 93,300



Chain blade	Pitch: 3/8" Gauge: 1.5mm (.058")
Displacement	79.0mL
Engine power	4.3kW / 5.8PS
Fuel tank	0.75L
Chain oil tank	0.42L
Sound pressure level	105.1dB(A)
Sound power level	115.3dB(A)
Vibration level Front handle	6.6m/s ²
Vibration level Rear handle	4.5m/s ²
Power head weight	6.3kg (13.8 lbs)



Guide Bar, Saw Chain, Guide Bar Cover, Socket Wrench, -Screwdriver

EA7900P60E - Petrol Chain Saw

Ergonomically designed down to micromillimeter for professionals. High performance engine.

EA7900P60E - Rs. 1,00,500



Chain blade	Pitch: 3/8" Gauge: 1.5mm (.058")
Displacement	79.0mL
Engine power	4.3kW / 5.8PS
Fuel tank	0.75L
Chain oil tank	0.42L
Sound pressure level	105.1dB(A)
Sound power level	115.3dB(A)
Vibration level Front handle	6.6m/s ²
Vibration level Rear handle	4.5m/s ²
Power head weight	6.3kg (13.8 lbs)



Guide Bar, Saw Chain, Guide Bar Cover, Socket Wrench, -Screwdriver



DCS7300 - Petrol Chain Saw

For professional chain saw with ergonomic designed body.

DCS7300 - Rs. 68,200



Chain blade	Pitch: 3/8" Gauge: 0.058"
Displacement	73cc
Engine power	4.2kW / 5.7hp
Fuel tank	0.75L
Chain oil tank	0.42L
Power head weight	6.3kg



Chain Blade, Guide Bar Cover, Wrenches

DCS9010 - Petrol Chain Saw

Ergonomically designed down to micromillimeter for professionals. High performance engine.

DCS9010 - Rs. 1,28,000



Chain blade	Pitch: 3/8" Gauge: 1.5mm (.058")
Displacement	90mL
Engine power	4.9kW / 6.7PS
Fuel tank	1L
Chain oil tank	0.4L
Sound pressure level	103dB(A)
Sound power level	114dB(A)
Vibration level Front handle	7.0m/s ²
Vibration level Rear handle	6.2m/s ²
Power head weight	8.2kg (18.1lbs)



Guide Bar, Saw Chain, Guide Bar Cover, Socket Wrench, -Screwdriver

UC4041A - Electric Chain Saw

Transverse motor allows for use of simple spur gear mechanism, providing high transmission durability.

UC4041A - Rs. 13,900



Continuous rating Input	1,800W
Chain speed per minute	870m/min (2,900ft/min)
Guide bar length	400mm (16")
Chain blade	Pitch: 3/8" Gauge: 1.1mm (.043") / or 1.3mm (.050")
Sound pressure level	90.3dB(A)
Sound power level	101.3dB(A)
Vibration level	4.7m/s ²
Dimensions (L x W x H)	455x245x200mm (17-7/8"x9-5/8"x7-7/8")
Net weight	4.8 - 4.9 kg (10.5 - 10.7 lbs)
Power supply cord	0.3m (0.98ft)



Saw Chain, Guide Bar Cover, Hook complete

DUC353Z - Cordless Chain Saw

18V X2 (36V) LXT BL Brushless Cordless 35 cm (14") Chain Saw

DUC353Z - Rs. 36,000



Li-ion Ah	4.0	2.0	1.5		
Guide Bar Length	350 mm (14")				
Chain Pitch	3/8"				
Chain Gauge	1.1 (0.043")				
Chain Speed	0 - 20 m/s (0 - 1,200 m/min) (0 - 3,940 FPM)				
Chain Oil Tank Volume	200 mL (N/A US oz)				
Sound Pressure Level	87.7 dB(A)				
Sound Power Level	100.4 dB(A)				
Vibration Level	Cutting Wood: 5.3 m/s ²				
Dimensions (L x W x H)	773x215x235 mm (30-1/2"x8-1/2"x9-1/4")				
Net weight	4.6 - 5.5 kg (10.2 - 12.1 lbs)				



Saw Chain, Guide Bar, Guide Bar Cover, Oil supply



DUC254 - Cordless Chain Saw

18V LXT BL Brushless Cordless 25 cm (10") Chain Saw

DUC254Z - Rs. 30,000



Li-ion Ah	2.6	2.2			
Guide Bar Length	250 mm (10")				
Cutting length	240 mm (N/A)				
Chain Pitch	3/8"				
Chain Gauge	1.1 mm (0.043")				
Chain Speed	0 - 24 m/s (0 - 1,440 m/min) (0 - 4,720 FPM)				
Chain Oil Tank Volume	140 mL (4.7 US oz)				
Max Output	570 W				
Sound Pressure Level	92.2 dB(A)				
Sound Power Level	103.2 dB(A)				
Vibration Level	Cutting Wood: 3.1 m/s ²				
Dimensions (L x W x H)	w/o Guide Bar: 258x184x191 mm (10-1/8"x7-1/4"x7-1/2")				
Net weight	2.8 - 3.2 kg (6.2 - 6.9 lbs.)				



Saw Chain, Guide Bar, Guide Bar Cover, Wrench, Accessory Bag

Hedge Trimmer

Environment-friendly 2-stroke engine

developed in compliance with: CARB Tier 3, EPA Phase 2, EU Stage 2, Safety regulations of the EC Directives

EH5000W/ EH6000W/ EH7500W



Catalytic Converter



Approx.
50
hours

Longer lubrication cycle obtained by circulating grease in gear housing
Competitors' models and our current models: approx. 20 hours

Photo:
EH7500W



5-Position rotating rear handle

Ergonomically angled and contoured grip of rear handle

Double-sided blade



Anti-vibration System

Equipped with floating structure of engine section and handle section for anti-vibration; four damper springs absorb vibration from engine to integrated front and rear handles.

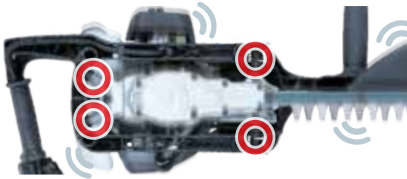

Blade Teeth with 3 Sharpened Edges

Stain-free shear blade surface of glittering silver obtained by non-electrolyzed nickel plating that features high anti-abrasion surface for long lasting coating



Sap on the blade
(after 10 hour trimming of Boxwood)



Stain-free Blade

Our Current models

5-Position Rotating Rear Handle (EH5000W, EH6000W, EH7500W)

can be locked at 0 degree and 45/ 90 degrees left and right for vertical or angled trimming.



EH5000W - Rs. 46,500
EH6000W - Rs. 49,800
EH7500W - Rs. 52,900

Petrol Hedge Trimmer

EH5000W 500mm, EH6000W 600mm, EH7500W 750mm (Double-sided blade)

	EH5000W	EH6000W	EH7500W
Blade length	500mm (19-3/4")	600mm (23-5/8")	750mm (29-1/2")
Displacement	22.2mL	22.2mL	22.2mL
Engine power	0.68kW / 1.0PS	0.68kW / 1.0PS	0.68kW / 1.0PS
Fuel Tank Capacity	0.4L	0.4L	0.4L
Cycles Per Minute (CPM)	2,195	2,195	2,195
Strokes Per Minute (SPM)	4,390	4,390	4,390
Tooth spacing	35mm (1-3/8")	35mm (1-3/8")	35mm (1-3/8")
Sound Pressure Level	93.0dB(A)	92.8dB(A)	93.9dB(A)
Sound Power Level	103.0dB(A)	103.2dB(A)	103.8dB(A)
Vibration Level Front Grip	2.5m/s ²	2.8m/s ²	2.3m/s ²
Vibration Level Rear Grip	2.5m/s ²	2.7m/s ²	2.3m/s ²
Dimensions (L x W x H)	1,014x262x216mm (40"x10-3/8"x8-1/2")	1,119x262x216mm (44"x10-3/8"x8-1/2")	1,259x262x216mm (49-1/2"x10-3/8"x8-1/2")
Net weight	4.8kg (10.5lbs)	5.0kg (11.0lbs)	5.2kg (11.4lbs)

Standard Equipment: Blade Cover, Socket Wrench, Hex Wrench



Electric Hedge Trimmer

More improved handling with Ergonomic multi-grip system

High Class **550W**

UH6570 650mm

Entry Class **400W**

UH5261 520mm

UH4261 420mm

Easy carbon brush replacement

Ergonomically designed rubberized grip

Mechanical brake

Two-handed safety switching in all applications



Each of the three grips is equipped with a switch. The blades start only when any two of the three switches are engaged at once, and stop immediately when one of the two switches is released.



Gripping Front and Main grips for easy hedge top trimming



Gripping Front and Sub grips for efficient hedge side trimming



Gripping Main and Sub grips for extra-long reach

Electric Hedge Trimmer

UH6570 650mm (25-1/2")

UH5261 520mm (20-1/2") / **UH4261** 420mm (16-1/2")

419

Double Insulation

Brake

Torque Limiter (UH6570)

UH6570 - Rs. 16,000
UH5261 - Rs. 12,900
UH4261 - Rs. 11,300

	UH6570	UH5261	UH4261
Continuous rating input	550W	400W	400W
Blade length	650mm (25-1/2")	520mm (20-1/2")	420mm (16-1/2")
Cycles Per Minute (CPM)	1,600	1,600	1,600
Strokes Per Minute (SPM)	3,200	3,200	3,200
Tooth spacing	18mm (11/16")	15mm (9/16")	15mm (9/16")
Sound Pressure Level	89.9dB(A)	82dB(A)	82dB(A)
Sound Power Level	97.9dB(A)	93dB(A)	93dB(A)
Vibration Level	6.7m/s ²	6.7m/s ²	6.7m/s ²
Dimensions (L x W x H)	1,042x223x206mm (41"x8-3/4"x8-1/8")	921x194x194mm (36-1/4"x7-5/8"x7-5/8")	821x194x194mm (32-1/4"x7-5/8"x7-5/8")
Net weight	3.8 - 3.9 kg (8.4 - 8.5 lbs)	3.0kg (6.7lbs)	2.9kg (6.4lbs)
Power supply cord	0.3m (0.98ft)	0.3m (0.98ft)	0.3m (0.98ft)

Standard Equipment: Blade Cover, Hook Complete, Cord holder complete set

DUH651 - Cordless Hedge Trimmer

18V X2 (36V) LXT Li-Ion Cordless, 65cm (25-1/2") Hedge Trimmer

DUH651Z - Rs. 35,000



new

XPT
EXTREME PROTECTION TECHNOLOGY



Li-ion Ah	5.0	4.0	3.0	2.0	1.5	442	MWh
Blade Length	650 mm (25-1/2")						
Strokes Per Minute (SPM)	2,000 - 3,600						
Tooth Spacing	36 mm (1-7/16")						
Sound Pressure Level	82 dB(A)						
Sound Power Level	91.1 dB(A)						
Vibration Level	2.5 m/s ² or less						
Dimensions (L x W x H)	1,135x225x200 mm (44-3/4"x8-7/8"x7-7/8")						
Net weight	4.7 - 5.5 kg (10.3 - 12.0 lbs)						



Blade Cover

DUH551 - Cordless Hedge Trimmer

18V X2 (36V) LXT Li-Ion Cordless 55cm (21-5/8") Hedge Trimmer

DUH551Z - Rs. 35,000



new

XPT
EXTREME PROTECTION TECHNOLOGY



Li-ion Ah	5.0	4.0	3.0	2.0	1.5	442	MWh
Blade Length	2,000 - 3,600						
Strokes Per Minute (SPM)	36 mm (1-7/16")						
Tooth Spacing	82 dB(A)						
Sound Pressure Level	91.1 dB(A)						
Sound Power Level	2.5 m/s ² or less						
Vibration Level	1,135x225x200 mm						
Dimensions (L x W x H)	(44-3/4"x8-7/8"x7-7/8")						
Net weight	4.7 - 5.5 kg (10.3 - 12.0 lbs)						



Blade Cover

UH201D - Cordless Hedge Trimmer

12V max CXT Li-Ion Cordless 20 cm (7-7/8") Hedge Trimmer

UH201DWY - Rs. 12,000

UH201DZ - Rs. 7,000



2in1



Li-ion Ah	4.0	2.0	1.5
Blade Length	200 mm (7-7/8")		
Tooth Spacing	26 mm (1")		
Strokes Per Minute (SPM)	2,500		
Continuous Use (min.)	w/ BL1041B / BL1021B / BL1016: 90 / 45 / 35 min		
Sound Pressure Level	74 dB(A)		
Vibration Level	2.5 m/s ² or less		
Dimensions (L x W x H)	504x120x131 mm (19-7/8"x4-3/4"x5-1/8")		
Net weight	1.3 - 1.5 kg (2.8 - 3.3 lbs)		

XPT CXT
EXTREME PROTECTION TECHNOLOGY

Blade Cover, Chip Receiver

EN5950SH - Petrol Pole Hedge Trimmer

Short shaft type powered by 25.4mL 4-stroke engine with multi-position engine lubrication system.

EN5950SH - Rs. 48,800



MM4



Displacement	25.4mL
Engine power	0.77kW / 1.1PS
Fuel tank	0.6L
Strokes per minute (spm)	4,200
Sound pressure level	87.1dB(A)
Sound power level	88.0dB(A)
Vibration level Front handle	6.8m/s ²
Vibration level Rear handle	9.6m/s ²
Dimensions (L x W x H)	1,780x242x241mm (70"x9-1/2"x9-1/2")
Net weight	6.0kg (13.2lbs)



Blade cover, Socket wrench, Accessory bag, Oil set, Hex wrench

EY2650H25H - Telescopic Petrol Pole Saw

Telescopic petrol pole saw loaded with a 25.4mL Makita 4-stroke engine.

EY2650H25H - Rs. 80,000



MM4



Displacement	25.4mL
Engine power	0.77kW / 1.1PS
Fuel tank	0.6L
Guide bar length	255mm (10")
Saw chain	Gauge: 1.3mm (.050") Pitch: 3/8"
Sound pressure level	89.5dB(A)
Sound power level	107.3dB(A)
Vibration level Left handle	7.2m/s ²
Vibration level Right handle	5.3m/s ²
Dimensions (L x W x H)	2,720x223x240mm (107"x8-3/4"x9-1/2")
Net weight	7.2kg (16.0lbs)



Blade cover, Tool set, Oil set

EVH2000 - Sprayer

24.5 mL MM4 Sprayer

EVH2000 - Rs. 80,000



Li-ion Ah 5.0 4.0 3.0 2.0 1.5

Displacement	24.5mL
Fuel Tank Capacity	0.5L
Max pressure	2.5Mpa (25kgf/cm ²)
Chemical tank	20L
Dimensions (L x W x H)	380x420x635mm (15"x16-1/2"x25")
Net weight	9.1kg (20.1lbs)



DVF104 - Cordless Garden Sprayer

18V LXT Li-Ion Cordless 10 L Garden Sprayer

DVF104Z - Rs. 49,000



new



Li-ion Ah	5.0	4.0	3.0	2.0	1.5
Max Pressure	0.3 MPa (3 kgf/cm ²)				
Chemical tank	10 L				
Dimensions (L x W x H)	315x225x415 mm (12-3/8"x8-7/8"x16-3/8")				
Net weight	3.8 - 4.1 kg (8.4 - 9.1 lbs)				

Upright Double-Headed Nozzle, Wide-Angle Herbicide Nozzle, Spray Pipe Holder, Shoulder Harness

DVF154 - Cordless Garden Sprayer

18V LXT Li-Ion Cordless 15 L Garden Sprayer

DVF154Z - Rs. 50,000



new



Li-ion Ah	5.0	4.0	3.0	2.0	1.5
Max Pressure	0.3 MPa (3 kgf/cm ²)				
Chemical tank	15 L				
Dimensions (L x W x H)	345x235x525 mm (13-5/8"x9-1/4"x20-3/4")				
Net weight	4.1 - 4.4 kg (9.1 - 9.7 lbs)				

Upright Double-Headed Nozzle, Wide-Angle Herbicide Nozzle, Spray Pipe Holder, Shoulder Harness

▣ Petrol Blower

High power and lightweight

MM4

MAKITA MINI 4-STROKE ENGINE

Larger air volume

15
m³/min

Max air velocity

98
m/s

Tube-mounted throttle
EB5300TH



Improved by 20% in air flow efficiency

Fan shape has been changed. Air can be pushed out smoothly with less air flow loss. (compared with our current Fan)



Easy-to-pull recoil starter

Low vibration for reduced operator stress and fatigue

- Vibration to the back of operator is reduced by the 4 damper springs mounted between the engine and the backpack frame.
- Vibration at the handle is significantly reduced by effectively damping transmission of vibration from the engine to the nozzle.



Comfortable backpack harness

Cushioning back padding and shoulder straps are well-ventilated for effective sweat evaporation.



Adjust straps to provide a perfect fit for every user.



Petrol Blower

EB5300TH 52.5 mL 4-stroke Tube-mounted throttle

- Anti Vibration
- Primer Pump
- Capacitor Discharge Ignition
- Auto Decompression

	EB5300TH	EB5300TH - Rs. 51,700
Displacement	52.5 mL	
Power Rating	1.8 kW (2.5 PS)	
Max Air Volume	15 m ³ /min (516 CFM)	
Max Air Velocity	98 m/s (220 MPH)	
Fuel Tank Capacity	1.8 L (61 oz.)	
No Load Speed (RPM)	2,800 - 6,400	
Sound Pressure Level	96.0 dB(A)	
Sound Power Level	102.5 dB(A)	
Vibration Level Right / Left Handle	Long Pipe, Volume Nozzle: 2.2 m/s ² / - Long Pipe, Flat Nozzle: 2.9 m/s ² / - Short Pipe, Circular Nozzle: 2.2 m/s ² / - Short Pipe, Flat Nozzle: 2.5 m/s ² / -	
Dimensions (L x W x H)	320x450x475 mm (12-5/8"x17-3/4"x18-3/4")	
Net weight	9.8 - 10.1 kg (21.7 - 22.3 lbs)	

Standard Equipment :

Oil bottle set, Box Wrench, Driver, Flexible Pipe, Swivel Pipe, Hose Clamp, End nozzle, Flat Nozzle, Long Pipe, Short Pipe, Accessory Bag, Cable Holder



EB7660TH - Petrol Blower

Powerful. Low vibration and comfortable backpack harness for professional use.

EB7660TH - Rs. 72,600



Displacement	75.6 mL
Power Rating	3.0 kW (4.1 PS)
Max Air Volume	20 m ³ /min (706 CFM)
Max Air Velocity	92 m/s (205 MPH)
Fuel Tank Capacity	1.9 L (64 oz.)
No Load Speed (RPM)	2,800 - 7,200
Sound Pressure Level	102.8 dB(A)
Sound Power Level	110.7 dB(A)
Vibration Level Right Handle	Long Pipe, Circular Nozzle: 2.3 m/s ² Long Pipe with Flat Nozzle: 3.4 m/s ² Short Pipe, Circular Nozzle: 2.3 m/s ² Short Pipe with Flat Nozzle: 3.5 m/s ²
Dimensions (L x W x H)	332x460x480 mm (13-1/8"x18-1/8"x18-7/8")
Net weight	11.9 - 12.1 kg (26.2 - 26.7 lbs)

Net weight: without fuel with blower pipe, Overall length: Without blower pipes



Oil bottle set, Box wrench 16, Driver, Flexible pipe, Swivel pipe, Hose clamp, End nozzle 90-60, End nozzle 90-70, Flat nozzle 90

BHX2500 - Petrol Blower

Take out the hard work out of clearing leaves and garden debris.

BHX2500 - Rs. 32,800



Displacement	24.5 mL
Power Rating	0.81 kW
Max Air Volume	10.1 m ³ /min (356 CFM)
Max Air Velocity	65 m/s (145 MPH)
Fuel Tank Capacity	0.52 L (17.6 oz.)
Sound Pressure Level	88.7 dB(A)
Sound Power Level	102 dB(A)
Vibration Level	5.2 m/s ²
No Load Speed (RPM)	3,500 - 7,800
Dimensions (L x W x H)	350x231x368 mm (13.8"x9.1"x14.5")
Net weight	4.5 kg (9.8 lbs)



Pipe, Nozzle, Socket Wrench

Net weight: without fuel with blower pipes, Overall length: Without blower pipes

RBL500 - Petrol Blower

For pro's landscape and maintenance work.

RBL500 - Rs. 56,000



Displacement	48.6 mL
Fuel mixture	50 : 1
Fuel tank	1.8 L
Max. air volume	10m ³ / min (353cu.ft / min)
The velocity of the wind (without blower pipes)	59.3 m/s 310x460x435mm
Dimensions (L x W x H)	(12-1/4"x18-1/8"x17-1/8")
Net weight	8.7 kg (19.1 lbs)



End Pipe, Flexible Pipe, Pipes 2

Net weight: without fuel with blower pipes, Overall length: Without blower pipes

PM7650H - Mist Blower

Comfortable backpack harness, well balanced chemical tank design.

PM7650H - Rs. 77,700



Displacement	75.6 mL
Fuel Tank Capacity	1.8 L
Max Air Volume	14.1 m ³ /min (497 CFM)
The velocity of the wind (without blower pipes)	85 m/s
Sound Pressure Level	98.3 dB(A)
Sound Power Level	110.7 dB(A)
Vibration Level	3.5 m/s ²
Dimensions (L x W x H)	420x440x595 mm (16-1/2"x17-1/4"x23-1/2")
Net weight	13.9 kg (30.6 lbs)



Oil bottle, Hand strap, Screwdriver, Diffusion cover, Hose clamp, Flexible pipe, Straight pipe

Net weight: without fuel with blower pipe, Overall length: Without blower pipes

DUB361 - Cordless Blower

18V X2 (36V) LXT Li-Ion Cordless 2-Speed Blower

DUB361Z - Rs. 19,000



Li-ion	Ah 4.0 2.0 1.5	430	MM
Max Air Volume	High: 4.4 m ³ /min (155 CFM) Low: 2.6 m ³ /min (92 CFM)		
Max Air Velocity	High: 93 m/s (208 MPH) Low: 57 m/s (128 MPH)		
No Load Speed (RPM)	High: 17,000 Low: 10,000		
Sound Pressure Level	82.3 dB(A)		
Sound Power Level	94.7 dB(A)		
Vibration Level	2.5 m/s ² or less		
Dimensions (L x W x H)	905x141x194 mm (35-5/8"x5-5/8"x7-5/8")		
Net weight	3.1 - 3.2 kg (6.8 - 7.1 lbs)		



Shoulder Belt, Nozzle

DUB362 - Cordless Blower

18V X2 (36V) LXT BL Brushless Cordless Variable 6-Speed Blower

DUB362Z - Rs. 28,000



Li-ion	Ah 4.0 2.0 1.5		
Max Air Volume	13.4 m ³ /min (473 CFM)		
Max Air Velocity	54 m/s (120 MPH)		
No Load Speed (RPM)	11,400 - 21,500		
Sound Pressure Level	79.1 dB(A)		
Sound Power Level	93.5 dB(A)		
Vibration Level	2.5 m/s ² or less		
Dimensions (L x W x H)	830/880/930x205x295 mm (32-3/4"/34-3/4"/36-5/8"x8-1/8"-11-5/8")		
Net weight	3.5 - 4.2 kg (7.7 - 9.3 lbs)		



Shoulder Belt, Nozzle

DUB183 - Cordless Blower

Long leaf blower nozzle with curved at end enables to use the machine comfortably in an upright standing posture.

DUB183Z - Rs. 6,000



Li-ion	Ah 5.0 4.0 3.0 1.5		
Air volume	2.6 m ³ /min		
Air speed	52 m/s		
No load speed (rpm)	0-18,000		
Sound pressure level	85 dB(A)		
Sound power level	95 dB(A)		
Vibration level	2.5 m/s ²		
Dimensions (L x W x H)	845x155x212 mm (33-1/4"x6-1/8"x8-3/8")		
Net weight	1.7 kg (3.8 lbs)		



Leaf blower nozzle



Others



EW1050H - Pump

25.4 mm (1") 24.5 mL MM4 Clear Water Pump **EW1050H - Rs. 35,000**



Displacement	24.5 mL
Suction & Discharge diameter	25.4 mm (1")
Max pumping capacity	120 L/min (32 gal/min)
Total head	41 m (135 ft)
Fuel Tank Capacity	0.5 L
Max suction head	8.0 m (26 ft)
Engine model	EH025
Dimensions (L x W x H)	327x225x319 mm (12-7/8"x8-7/8"x12-1/2")
Net weight	5.8 kg (12.8 lbs)

MM4



Hose, Strainer, Oil Bottle

EW1060H - Pump

25.4 mm (1") 33.5 mL MM4 Clear Water Pump **EW1060H - Rs. 41,600**



Displacement	33.5 mL
Suction & Discharge diameter	25.4 mm (1")
Max pumping capacity	130 L/min (34 gal/min)
Total head	48 m (157 ft)
Fuel Tank Capacity	0.65 L
Max suction head	8.0 m (26 ft)
Engine model	EH026
Dimensions (L x W x H)	356x234x336 mm (14"x9-1/4"x13-1/4")
Net weight	7.3 kg (16.1 lbs)

MM4



Hose, Strainer, Oil Bottle

UK360D - Cordless Cultivator

36V LXT Li-Ion Cordless Cultivator **UK360DZ - Rs. 1,00,000**



Li-ion Ah	2.6	2.2			
Capacity	Width: 350/225 mm (13-3/4"/8-7/8")				
Blade Diameter	245 mm (9-5/8")				
Dimensions (L x W x H)	1,193x488x998 mm (47"x19-1/4"x39-1/4")				
Max Output	0.72 kW				
Net weight	23.3 kg (51.4 lbs)				



Tray set, Holder

BBA520 - Earth Auger - 2-stroke engine

Designed for easy one man operation. It is the low cost energy saving solution for drilling holes for fence posts, trees, shrubs and young plants. **BBA520 - Rs. 63,800**



Displacement	51.7cc
Engine power	2.7hp
Fuel tank	0.9L
Max. drilling dia	200mm
Dry Weight	10.5kg (Without Auger bit)

Auger bit

DUP361 - Cordless Pruning Shear

18V X2 (36V) LXT Li-Ion Battery Powered Pruning Shears **DUP361Z - Rs. 1,20,000**

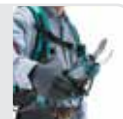

Li-ion Ah	5.0	4.0	3.0	2.0	1.5
Max Output	200 W				
Capacity	Max cutting : 33 mm				
	Max blade opening: 54 mm				
Sound Pressure Level	70 dB(A) or less				
Vibration Level	2.5 m/s ² or less				
Dimensions (L x W x H)	305x43x106 mm (12"x1-11/16"x4-3/16")				
Net weight	0.8 kg (1.8 lbs)				



Oil supply, Wrench set, Diamond File, Cord holder complete, Holster, Harness, Arm band, Tool bag, Shear blade

DUM168 - Cordless Grass Shear

Both trimmer blade and shear blade can be attached. **DUM168Z - Rs. 9,000**



Li-ion Ah	5.0	4.0	3.0	1.5
Cutting width	160mm (6-5/16")			
Strokes per minute (spm)	1,250			
Dimensions (L x W x H)	353x176x130mm (13-7/8"x6-15/16"x5-1/8")			
Net Weight	1.4kg (3.1lbs)			





High Pressure Washer

HW1200



12 MPa (120 Bar) High Pressure Washer with Self-Priming Function

- Pressure adjustable function for easy and quick control by turning the handle
- Makita-built powerful 1,800 W series motor provides up to 12 MPa (120 bar) for maximum cleaning power
- 420 L/hr max flow rate
- Powerful washing 10 MPa (100 bar) of working pressure (up to 50X as tap water)
- Lightweight and compact, middle class power washer for home and professional use



Trigger Gun, Vario-Power Spray Lance, Cyclone jet nozzle, Detergent Bottle, Cleaner Pin, Coupling Sleeve, High Pressure Hose 10 m, Water Hose Connector, Foam Nozzle, Connector

HW1200 - Rs. 28,000

Continuous rating input	1,800W
Max Pressure	12 MPa (120 bar, 1,740 PSI)
Max Flow Rate	420 L/h
Max Feed Temperature	40 °C (104 °F)
High Pressure Hose	10 m (33 ft.)
Length	
Sound Pressure Level	72 dB(A)
Vibration Level	4.11 m/s ²
Dimensions (L x W x H)	292x358x830 mm (11-1/2"x14-1/8"x32-3/4")
Net weight	11.0 kg (24.3 lbs.)
Power supply cord	5.0 m (16.4 ft.)

High Pressure Washer

HW1300



13 MPa (130 Bar) High Pressure Washer with Self-Priming Function

- Pressure adjustable function and low noise mode
- Pressure adjustable function for easy and quick control by turning the handle
- Low noise mode enables soft washing of screen door, air conditioner outdoor unit, car, etc.
- Makita-built powerful 1,800 W series motor provides up to 13 MPa (130 bar) for maximum cleaning power
- 450 L/hr max flow rate



Trigger Gun, Vario-Power Spray Lance, Cyclone jet nozzle, Detergent Bottle, Cleaner Pin, Coupling Sleeve, High Pressure Hose 10 m, Water Hose Connector, Foam Nozzle, Connector

HW1300 - Rs. 34,000

Continuous rating input	1,800W
Max Pressure	13 MPa (130 bar, 1,885 PSI)
Max Flow Rate	420 L/h
Max Feed Temperature	40 °C (104 °F)
High Pressure Hose	10 m (33 ft.)
Length	
Sound Pressure Level	76 dB(A)
Vibration Level	4.86 m/s ²
Dimensions (L x W x H)	292x358x830 mm (11-1/2"x14-1/8"x32-3/4")
Net weight	12.7 kg (28.0 lbs.)
Power supply cord	5.0 m (16.4 ft.)



Various options

HW1200

HW1300





HW102 - High Pressure Washer

Lightweight and compact power washer for home use.

HW102 - Rs. 11,600



Continuous rating Input	1,300W
Max. pressure	100bar (1,450 PSI)
Max. flow	360 L/hr
Motor type	Universal
Sound pressure level	85.74dB(A)
Sound power level	94dB(A)
Max. input temperature	50°C
High pressure hose length	5m(16.4ft)
Net weight	5.8kg (5.0lbs)

HW111 - High Pressure Washer

Lightweight and compact power washer for home use.

HW111 - Rs. 19,500



Continuous rating Input	1,700W
Max. pressure	110bar (1,595 PSI)
Max. flow	370 L/hr
Motor type	Universal
Sound pressure level	79.15dB(A)
Sound power level	87dB(A)
Max. input temperature	50°C
High pressure hose length	5.5m(16.4ft)
Net weight	7.4kg (6.4lbs)

HW121 - High Pressure Washer

Made for frequent usage on larger, dirty or very dirty areas. Ergonomical and powerful handling.

HW121 - Rs. 32,700



Continuous rating Input	1,800W
Max. pressure	130bar (1,885 PSI)
Max. flow	390 L/hr
Motor type	Induction
Sound pressure level	77.33dB(A)
Sound power level	85dB(A)
Max. input temperature	50°C
High pressure hose length	8m(26.2ft)
Net weight	17.8kg (15.4lbs)

Power Cutter



DPC6430 - Power Cutter

Icon of ergonomic power cutter features enlarged air filter.

DPC6430 - Rs. 96,300



Wheel diameter	300mm (12")
Engine	64cc
Max. cutting depth	97mm (3-13/16")
No load speed (rpm)	4,300
Circumferential speed	80m/s
Engine power	4.5hp
Fuel mixture	50:1
Fuel tank	1.1L
Overall length	770mm (30-1/4")
Net Weight	9.4kg



DPC7331 - Power Cutter

Icon of ergonomic power cutter features enlarged air filter.

DPC7331 - Rs. 1,07,500



Wheel diameter	350mm (14")
Engine	73cc
Max. cutting depth	122mm (4-13/16")
No load speed (rpm)	4,300
Circumferential speed	80m/s
Engine power	5.7hp
Fuel mixture	50:1
Fuel tank	1.1L
Sound pressure level	99.5dB(A)
Sound power level	108.9dB(A)
Vibration level Front handle	5.7m/s ²
Vibration level Rear handle	5.1m/s ²
Overall length	800mm (31-1/2")
Net weight	10.0kg



DPC8132 - Power Cutter

81mL engine with a disc diameter of 400mm (16").

DPC8132 - Rs. 1,17,500



Wheel diameter	400mm (16")
Engine	81cc
Max. cutting depth	147mm (5-3/4")
Circumferential speed	80m/s
Engine power	6.2hp
Fuel tank	1.0L
Sound pressure level	100.3dB(A)
Sound power level	109.6dB(A)
Vibration level Front handle	7.8m/s ²
Vibration level Rear handle	6.1m/s ²
Overall length	830mm (32-3/4")
Net weight	10.6kg (23.4lbs)



EK8100 - Power Cutter

405 mm (16") 81 mL 2-Stroke Power Cutter

EK8100 - Rs. 1,22,000



Wheel Diameter	405 mm (16")
Engine	81 mL
Max cutting depth	147 mm (5-3/4")
Circumferential speed	80 m/s
Engine power	4.2 kW / 5.6 PS
Fuel Tank Capacity	1.1 L
Sound Pressure Level	100.3 dB(A)
Sound Power Level	109.6 dB(A)
Vibration Level Front Grip	7.8 m/s ²
Vibration Level Rear Grip	6.1 m/s ²
Overall Length	830 mm (32-3/4")
Net weight	10.6 kg (23.4 lbs)



Power Cutter

Environment-Friendly and Cost-Saving 4-Stroke Engine.

- /// Low-vibration system with damper springs to absorb vibration from engine to integrated front and rear handles.
- /// Easy start-up with Automatic decompression, Primer pump and on/off choke combination switch with automatic half-throttle lock.
- /// Casters for moving convenience.

MM4
MAKITA MINI 4-STROKE ENGINE



75.6mL

355mm (14")
EK7651H



Photo: EK7651H



with Trolley kit DT4000

EK7651H - Rs. 1,20,000

Power Cutter	EK7651H 355mm (14") 4-stroke
	EK7651H
Wheel Diameter	355mm (14")
Engine	75.6mL
Max cutting depth	122mm (4-13/16")
No Load Speed (RPM)	4,300
Circumferential speed	80m/s
Engine power	3.0kW / 4.1PS
Sound Pressure Level	92.7dB(A)
Sound Power Level	104.6dB(A)
Vibration Level Front / Rear Grip	2.7m/s ² / 1.8m/s ²
Fuel Tank Capacity	1.1L
Dimensions (L x W x H)	780x310x455mm
	(30-3/4"x12-1/4"x17-7/8")
Net weight	14.2 kg (31.3 lbs)

Net weight: without blade and fuel. Trolley and foot with wheels are available as option.

Standard Equipment: Engine tool set, Oil Bottle (country-specific), Water supply set

Makita®

mt



New Lineup

Drilling / Fastening

M0600B - Drill

10 mm (3/8") 350 W Variable Speed Reversing Drill with Keyed Chuck **M0600B - Rs. 3,100**



Continuous rating input	350W
Capacity	Steel: 10 mm (3/8") Wood: 20 mm (13/16")
No Load Speed (RPM)	0 - 3,000
Vibration Level	Drilling Into Metal: 3.0 m/s ²
Sound Pressure Level	77 dB(A)
Dimensions (L x W x H)	230x66x176 mm
Net weight	1.2 kg (2.6 lbs)
Power supply cord	2.0 m (6.6 ft)

Chuck Key, Chuck Key Holder

M6501B - High Speed Drill

6.5 mm (1/4") 230 W High Speed Variable Speed Reversing Drill with Keyed Chuck **M6501B - Rs. 3,800**



Continuous rating input	230W
Capacity	Steel: 6.5 mm (1/4") Wood: 9 mm (11/32")
No Load Speed (RPM)	0 - 4,500
Vibration Level	Drilling Into Metal: 3.0 m/s ²
Sound Pressure Level	70 dB(A)
Dimensions (L x W x H)	203x63x171 mm
Net weight	0.95 kg (2.1 lbs)
Power supply cord	2.0 m (6.6 ft)

Chuck Key

M6202XB - Drill

13 mm (1/2") 580 W Drill **M6202XB - Rs. 5,200**



Continuous rating input	580W
Capacity	Steel: 13 mm (1/2") Wood: 25 mm (1")
No Load Speed (RPM)	2,000
Dimensions (L x W x H)	239x69x178 mm (9-3/8"x2-3/4"x7")
Net weight	1.7 kg (3.7 lbs.)
Power supply cord	2.0 m (6.6 ft.)

Side Grip, Wrench

M6200B - Drill

13 mm (1/2") 800 W Variable Speed Drill with Keyed Chuck **M6200B - Rs. 8,300**



Continuous rating input	800W
Capacity	Steel: 13 mm (1/2") Wood: 36 mm (1-7/16")
No Load Speed (RPM)	0 - 700
Vibration Level	Drilling Into Metal: 2.5 m/s ² or less
Sound Pressure Level	84 dB(A)
Sound Power Level	95 dB(A)
Dimensions (L x W x H)	267x86x388 mm
Net weight	2.7 kg (6.0 lbs.)
Power supply cord	2.0 m (6.6 ft.)

Chuck Key, Top Grip, Chuck Key Holder

M6600B - Mixer

165 mm (6-1/2") 800 W Variable Speed Mixer **M6600B - Rs. 8,500**



Continuous rating input	800W
Blade Diameter	165 mm (6-1/2")
No Load Speed (RPM)	0 - 700
Vibration Level	2.5 m/s ² or less
Sound Pressure Level	85 dB(A)
Sound Power Level	96 dB(A)
Dimensions (L x W x H)	280x86x388 mm
Net weight	2.6 - 2.7 kg (5.7 - 5.9 lbs)
Power supply cord	2.0 m (6.6 ft.)

Wrenches, Side grip

Impact Drilling

M0801B - Hammer Drill

16 mm (5/8") 500 W Variable Speed Reversing Hammer Drill with Keyed Chuck **M0801B - Rs. 4,700**



Continuous rating input	500W
Capacity	Concrete: 16 mm (5/8") Steel: 13 mm (1/2") Wood: 20 mm (13/16")
Blows Per Minute (BPM)	0 - 48,000
No Load Speed (RPM)	0 - 3,200
Vibration Level	Hammer Drilling Into Concrete: 14.5 m/s ² Drilling Into Metal: 4.0 m/s ²
Sound Pressure Level	94 dB(A)
Sound Power Level	105 dB(A)
Dimensions (L x W x H)	261x69x195 mm
Net weight	1.7 kg (3.7 lbs)
Power supply cord	2.0 m (6.6 ft)

Side Grip, Chuck Key, Chuck Key Holder



M8700B - Rotary Hammer

22 mm (7/8") 1.9 J Rotary Hammer, SDS-PLUS Bits

M8700B - Rs. 11,300



459



Side Grip, Depth Gauge

Continuous rating input	710W
Impact Energy	EPTA-Procedure 05/2009: 1.9 J
Capacity	Concrete: 22 mm (7/8") Core Bit: 54 mm (2-1/8") Diamond Core Bit (Dry Type): 65 mm Steel: 13 mm Wood: 32 mm
Blows Per Minute (BPM)	0 - 4,350
No Load Speed (RPM)	0 - 1,100
Vibration Level	Hammer Drilling Into Concrete: 15.5 m/s ² Drilling Into Metal: 3.0 m/s ²
Sound Pressure Level	90 dB(A)
Sound Power Level	101 dB(A)
Dimensions (L x W x H)	362x71x194 mm
Net weight	2.5 - 2.9 kg (5.6 - 6.4 lbs)
Power supply cord	4.0 m (13.1 ft.)

Tool does not come with bit.

M8701B - Combination Hammer

26 mm (1") 2.3 J Combination Hammer, SDS-PLUS bits

M8701B - Rs. 12,700



325



Side Grip, Depth Gauge

Continuous rating input	800W
Impact Energy	EPTA-Procedure 05/2009: 2.3 J
Capacity	Concrete: 26 mm (1") Core Bit: 68 mm (2-11/16") Diamond Core Bit (Dry Type): 80 mm (3-1/8") Steel: 13 mm (1/2") Wood: 32 mm (1-1/4")
No Load Speed (RPM)	0 - 1,200
Blows Per Minute (BPM)	0 - 4,500
Sound Pressure Level	90 dB(A)
Sound Power Level	101 dB(A)
Dimensions (L x W x H)	362x71x194 mm
Net weight	2.7 kg (6.0 lbs)
Power supply cord	4.0 m (13.1 ft.)

Tool does not come with bit.

M8600B - Demolition Hammer

7.2 J Demolition Hammer, accepts 17 mm Hex Shank Bits

M8600B - Rs. 20,300



105



Bull Point, Side Grip, Bit Grease, Cleaning cloth



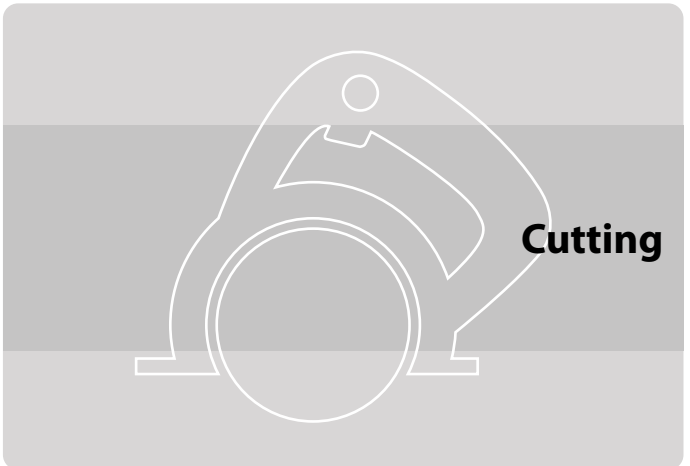

Continuous rating input	900W
Impact Energy	7.2 J
Blows Per Minute (BPM)	2,900
Vibration Level	Chiselling Funtion w/ Side Grip: 16.5 m/s ²
Sound Pressure Level	95 dB(A)
Sound Power Level	106 dB(A)
Dimensions (L x W x H)	406x99x232 mm (16"x3-7/8"x9-1/8")
Net weight	5.4 kg (12 lbs)
Power supply cord	2.5 m (8.2 ft.)

Tool does not come with bit.



High performance and durability

Cutting Capacity

Miter angle		0°	45°
Form of materials		ø127mm (5")	ø127mm (5")
		H x W: 102 x 194mm (4" x 7-5/8") 70 x 233mm (2-3/4" x 9-1/8")	H x W: 115 x 103mm (4-1/2" x 4-1/16")
		H x W: 119 x 119mm (4-11/16" x 4-11/16")	H x W: 106 (4-3/16) x 106 (4-3/16)
		S x S: 137 x 137mm, T: 10mm (5-3/8" x 5-3/8", 3/8")	S x S: 100 x 100mm, T: 10mm (4" x 4", 3/8")

* with Abrasive cut-off wheel 355

Carry handle for easy transportation

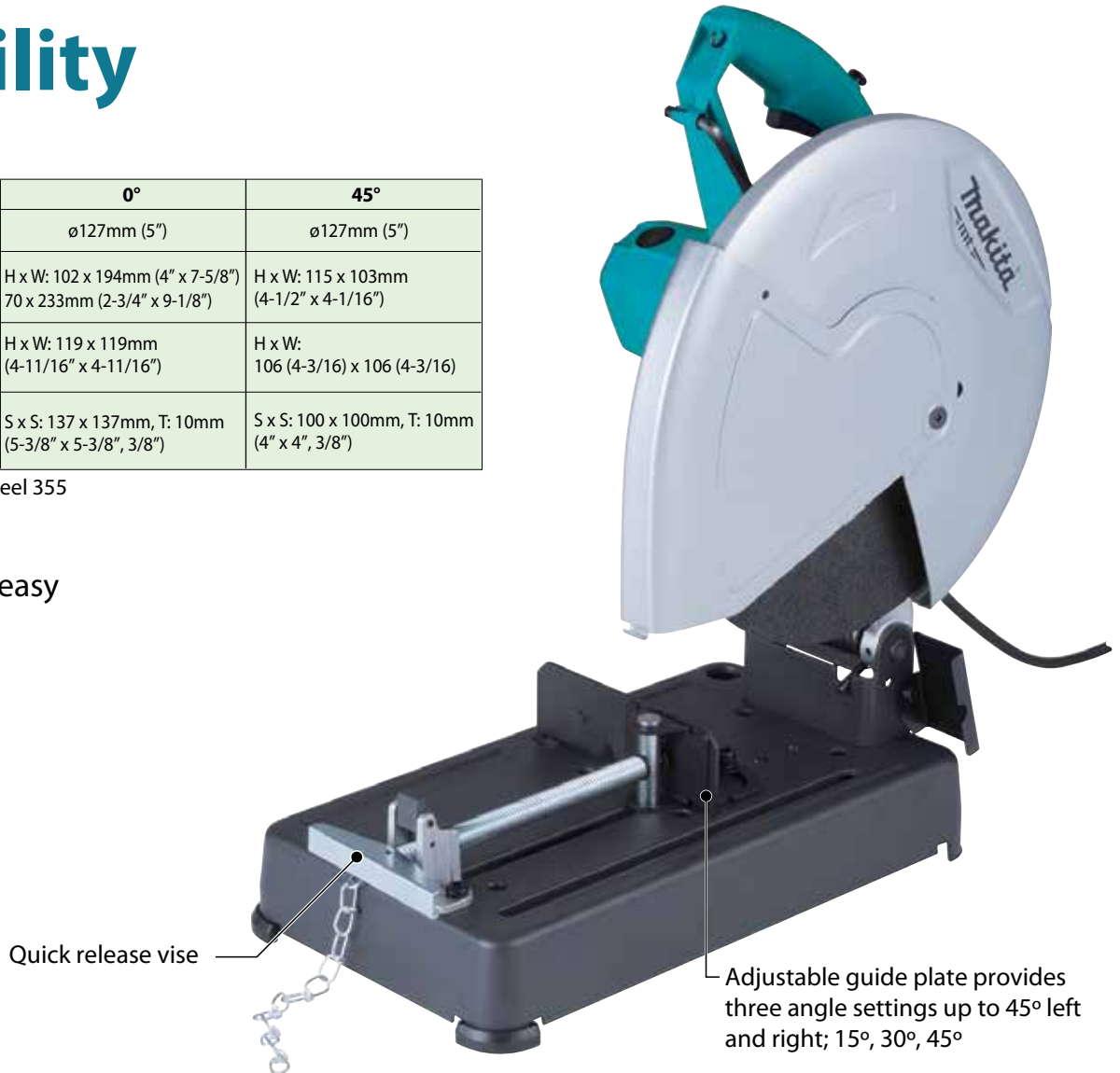

Quick release vise

Adjustable guide plate provides three angle settings up to 45° left and right; 15°, 30°, 45°

M2401B - Rs. 15,800



 Double Insulation

203 

Continuous rating Input	2,000W
Wheel diameter	355mm (14")
No load speed (rpm)	3,800
Dimensions (L x W x H)	500x280x620mm (19-3/4"x11"x24-3/8")
Net Weight	14.3kg (31.5lbs)
Power supply cord	2.5m (8.2ft)

Standard Equipment : Abrasive Cut-Wheel, Hex Wrench



M4100B - Cutter
110 mm (4-3/8") 1,200 W Cutter **M4100B - Rs. 5,600**



Continuous rating input	1,200W
Blade Diameter	110 mm (4-3/8")
Max Cutting Capacity	90°: 32 mm (1-1/4")
No Load Speed (RPM)	13,000
Vibration Level	Concrete Cutting: 5.5 m/s ²
Sound Pressure Level	100 dB(A)
Sound Power Level	111 dB(A)
Dimensions (L x W x H)	227x209x166 mm
Net weight	2.9 kg (6.4 lbs)
Power supply cord	2.0 m (6.6 ft.)

Wrench, Water supply fixture, Vinyl tube, Tube holder

M0401B - Cutter
110 mm (4-3/8") 1,200 W Cutter **M0401B - Rs. 5,100**



Continuous rating input	1,200W
Blade Diameter	110 mm (4-3/8")
Max Cutting Capacity	90°: 32.0 mm (1-1/4")
No Load Speed (RPM)	13,800
Vibration Level	Concrete Cutting: N/A m/s ²
Dimensions (L x W x H)	231x195x164 mm
Net weight	2.6 kg (5.7 lbs)
Power supply cord	2.0 m (6.6 ft.)

Tube Holder, Vinyl Tube, Wrench, Hex Wrench

M4101B - Cutter
125 mm (5") 1,250 W Cutter **M4101B - Rs. 6,100**



Continuous rating input	1,250W
Blade Diameter	125 mm (5")
Max Cutting Capacity	90°: 40 mm (1-9/16")
No Load Speed (RPM)	12,000
Vibration Level	Concrete Cutting: 5.0 m/s ²
Sound Pressure Level	98 dB(A)
Sound Power Level	109 dB(A)
Dimensions (L x W x H)	233x216x166 mm
Net weight	3.0 kg (6.7 lbs.)
Power supply cord	2.0 m (6.6 ft.)

Tube Holder (country-specific), Vinyl Tube, Wrench, Hex Wrench

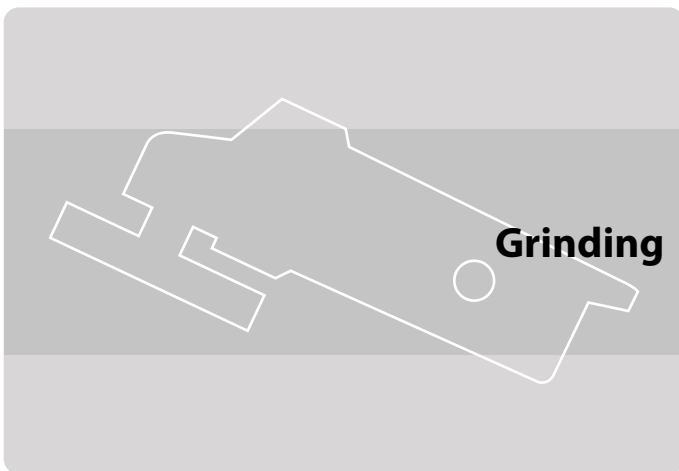

M0900B - Angle Grinder
100 mm (4") 540 W Angle Grinder, Slide Switch **M0900B - Rs. 4,000**



Continuous rating input	540W
Wheel Diameter	100 mm (4")
No Load Speed (RPM)	12,000
Dimensions (L x W x H)	251x118x97 mm
Net weight	1.6 kg (3.5 lbs)
Power supply cord	2.0 m (6.6 ft.)

Lock nut wrench

M0910B - Angle Grinder
100 mm (4") 540 W Angle Grinder, Toggle Switch **M0910B - Rs. 4,100**



Continuous rating input	540W
Wheel Diameter	100 mm (4")
No Load Speed (RPM)	12,000
Dimensions (L x W x H)	251x118x93 mm
Net weight	1.6 kg (3.4 lbs)
Power supply cord	2.0 m (6.6 ft.)

Lock Nut Wrench

M9506B - Angle Grinder
100 mm (4") 720 W Angle Grinder, Slide Switch **M9506B - Rs. 4,600**



Continuous rating input	720W
Wheel Diameter	100 mm (4")
No Load Speed (RPM)	11,000
Vibration Level	Surface Grinding: 6.5 m/s ²
Sound Pressure Level	86 dB(A)
Sound Power Level	97 dB(A)
Dimensions (L x W x H)	261x118x101 mm
Net weight	1.6 kg (3.6 lbs)
Power supply cord	2.0 m (6.6 ft.)

Lock Nut Wrench

M9509B - Angle Grinder

100 mm (4") 850 W Angle Grinder,
Slide Switch

M9509B - Rs. 4,900



Continuous rating input	850W
Wheel Diameter	100 mm (4")
No Load Speed (RPM)	11,000
Vibration Level	Surface Grinding: 6.5 m/s ²
Sound Pressure Level	87 dB(A)
Sound Power Level	98 dB(A)
Dimensions (L x W x H)	276x118x101 mm (10-7/8"x4-5/8"x4")
Net weight	1.8 kg (3.9 lbs)
Power supply cord	2.0 m (6.6 ft)

325



Lock Nut Wrench

M9512B - Angle Grinder

100 mm (4") 720 W Angle Grinder,
Toggle Switch

M9512B - Rs. 4,900



Continuous rating input	720W
Wheel Diameter	100 mm (4")
No Load Speed (RPM)	11,000
Dimensions (L x W x H)	258x118x101 mm (10-1/8"x4-5/8"x4")
Net weight	1.6 kg (3.5 lbs.)
Power supply cord	2.0 m (6.6 ft.)

459



Lock Nut Wrench

M9513B - Angle Grinder

100 mm (4") 850 W Angle Grinder,
Toggle Switch

M9513B - Rs. 4,900



Continuous rating input	850W
Wheel Diameter	100 mm (4")
No Load Speed (RPM)	11,000
Dimensions (L x W x H)	273x118x101 mm (10-3/4"x4-5/8"x4")
Net weight	1.8 kg (4.0 lbs.)
Power supply cord	2.0 m (6.6 ft.)

459



Lock Nut Wrench

M9002B - Angle Grinder

100 mm (4") 720 W Angle Grinder,
Toggle Switch

M9002B - Rs. 7,900



Continuous rating input	1,050W
Wheel Diameter	125 mm (5")
No Load Speed (RPM)	11,000
Vibration Level	Surface Grinding: 9.0 m/s ²
Sound Pressure Level	91 dB(A)
Sound Power Level	102 dB(A)
Dimensions (L x W x H)	361x140x124 mm (14-1/4"x5-1/2"x4-7/8")
Net weight	2.8 kg (6.1 lbs.)
Power supply cord	2.0 m (6.6 ft.)

303



Lock Nut Wrench

Tool does not come with depressed center wheel.

M9508B - Angle Grinder

125 mm (5") 720 W Angle Grinder,
Slide Switch

M9508B - Rs. 5,200



Continuous rating input	720W
Wheel Diameter	125 mm (5")
No Load Speed (RPM)	11,000
Vibration Level	Surface Grinding: 7.0 m/s ²
Sound Pressure Level	88 dB(A)
Sound Power Level	99 dB(A)
Dimensions (L x W x H)	261x140x111 mm (10-1/4"x5-1/2"x4-3/8")
Net weight	1.9 kg (4.1 lbs)
Power supply cord	2.0 m (6.6 ft)

459



Lock Nut Wrench

M9511B - Angle Grinder

125 mm (5") 850 W Angle Grinder,
Slide Switch

M9511B - Rs. 5,200



Continuous rating input	850W
Wheel Diameter	125 mm (5")
No Load Speed (RPM)	11,000
Vibration Level	Surface Grinding: 9.0 m/s ²
Sound Pressure Level	89 dB(A)
Sound Power Level	100 dB(A)
Dimensions (L x W x H)	276x140x111 mm (10-7/8"x5-1/2"x4-3/8")
Net weight	2.0 kg (4.5 lbs)
Power supply cord	2.0 m (6.6 ft)

325



Lock Nut Wrench

M0921B / M0920B - Angle Grinder

230 mm (9") 2,200 W Angle Grinder,
Finger Trigger Switch
180 mm (7") 2,200 W Angle Grinder, Finger Trigger Switch

M0921B - Rs. 9,200

M0920B - Rs. 8,600



Continuous rating input	2,200W
Wheel Diameter	M0921B: 230 mm (9") M0920B: 180 mm (7")
No Load Speed (RPM)	M0921B: 6,600 M0920B: 8,500
Sound Power Level	102 dB(A)
Dimensions (L x W x H)	M0921B: 439x250x141 mm (17-1/4"x9-7/8"x5-9/16") M0920B: 439x200x141 mm (17-1/4"x7-7/8"x5-9/16")
Net weight	M0921B: 5.3 kg (11.6 lbs) M0920B: 5.0 kg (11.0 lbs)
Power supply cord	2.0 m (6.6 ft)

203



Lock Nut Wrench, Side Grip

Tool does not come with depressed center wheel.

M9100B - Die Grinder

6 mm (1/4") 480 W High Speed Die Grinder,
Toggle Switch

M9100B - Rs. 6,000



Continuous rating input	480W
Capacity	Collet: 6 mm or 1/4"
Max Wheel Diameter	20 mm (13/16")
No Load Speed (RPM)	33,000
Vibration Level	Surface Grinding: 2.5 m/s ²
Dimensions (L x W x H)	350x75x75 mm (13-3/4"x2-15/16"x2-15/16")
Net weight	1.4 kg (3.1 lbs)
Power supply cord	2.0 m (6.6 ft)

411



Wrench (2pcs.) (Tool does not come with wheel point.)

M9200B - Finishing Sander

1/4 Sheet 180 W Finishing Sander

M9200B - Rs. 4,800



Continuous rating input	180W
Pad Size	112 x 102 mm (4-3/8" x 4")
Abrasive Paper Size	114 x 140 mm (4-1/2" x 5-1/2")
Orbits Per Minute (OPM)	14,000
Vibration Level	Sanding Metal Plate: 4.5 m/s ²
Sound Pressure Level	79 dB(A)
Dimensions (L x W x H)	110x112x133 mm (4-5/16"x4-3/8"x5-1/4")
Net weight	0.9 kg (2 lbs)
Power supply cord	2.0 m (6.6 ft)



Abrasive paper x6

M9201B - Finishing Sander

1/3 Sheet 180 W Finishing Sander

M9201B - Rs. 5,000



Continuous rating input	180W
Pad Size	93 x 185 mm (3-5/8" x 7-1/4")
Abrasive Paper Size	93 x 228 mm (3-5/8" x 9")
Orbits Per Minute (OPM)	12,000
Vibration Level	Sanding Metal Plate: 6 m/s ²
Sound Pressure Level	74 dB(A)
Dimensions (L x W x H)	214x92x147 mm (8-3/8"x3-5/8"x5-3/4")
Net weight	1.4 kg (3.1 lbs)
Power supply cord	2.0 m (6.6 ft)



Abrasive Paper

M9202B - Random Orbit Sander

125 mm (5") 240 W Random Orbit Sander

M9202B - Rs. 6,100



Continuous rating input	240W
Pad Size	123 mm (4-7/8")
Abrasive Disc Size	125 mm (5")
Orbits Per Minute (OPM)	12,000
Strokes Per Minute (SPM)	24,000
Orbit Diameter	2.8 mm (1/8")
Dimensions (L x W x H)	127x123x142 mm (5"x4-7/8"x5-5/8")
Net weight	1.1 kg (2.4 lbs)
Power supply cord	2.0 m (6.6 ft)



Abrasive Disc

M9400B - Belt Sander

100 mm x 610 mm (4" x 24") 940 W Belt Sander

M9400B - Rs. 15,300



Continuous rating input	940W
Belt Size	100 x 610 mm (4" x 24")
Belt Speed	380 m/min (1,250 ft/min)
Vibration Level	Sanding Metal Plate: 2.5 m/s ² or less
Sound Pressure Level	87 dB(A)
Sound Power Level	98 dB(A)
Dimensions (L x W x H)	354x175x169 mm (14"x6-7/8"x6-5/8")
Net weight	6.2 kg (13.7 lbs)
Power supply cord	2.0 m (6.6 ft)



Abrasive Belt, Dust Bag, Carbon Plate, Step



Sawing

M5801B - Circular Saw

185 mm (7-1/4") 1,050 W Circular Saw

M5801B - Rs. 15,300



Continuous rating input	1,050W
Blade Diameter	185 mm (7-1/4")
Max Cutting Capacity	90°: 66 mm (2-5/8") 45°: 44 mm (1-3/4")
No Load Speed (RPM)	4,900
Vibration Level	Cutting Wood: 2.5 m/s ²
Dimensions (L x W x H)	284x231x243 mm (11-1/8"x9-1/8"x9-9/16")
Net weight	3.5 kg (7.7 lbs)
Power supply cord	2.0 m (6.6 ft)



TCT Saw Blade, Rip Fence (Guide Rule), Hex Wrench

M4302B - Jig Saw

450 W Top Handle Variable Speed Jig Saw

M4302B - Rs. 9,200



Continuous rating input	450W
Max Cutting Capacity at 90°	Wood: 55 mm (2-3/16") Steel: 6 mm (1/4")
Length of Stroke	26 mm (1")
Strokes Per Minute (SPM)	0 - 3,100
Vibration Level	Cutting Boards: 6.5 m/s ² Cutting Sheet Metal: 7.5 m/s ²
Sound Pressure Level	88 dB(A)
Sound Power Level	99 dB(A)
Dimensions (L x W x H)	219x85x191 mm (8-5/8"x3-3/8"x7-1/2")
Net weight	2.5 kg (5.5 lbs)
Power supply cord	2.0 m (6.6 ft)



Jig Saw Blade, Hex Wrench

M4301B - Jig Saw

450 W Top Handle Jig Saw, 3 Orbital Settings Plus Straight Cutting

M4301B - Rs. 7,300



Continuous rating input	450W
Max Cutting Capacity at 90°	Wood: 65 mm (2-9/16") Steel: 6 mm (1/4")
Length of Stroke	18 mm (11/16")
Strokes Per Minute (SPM)	0 - 3,100
Vibration Level	Cutting Wood: 8.0 m/s ² Cutting Sheet Metal: 5.0 m/s ²
Sound Pressure Level	82 dB(A)
Sound Power Level	93 dB(A)
Dimensions (L x W x H)	214x75x202 mm (8-3/8"x2-15/16"x8")
Net weight	1.9 kg (4.1 lbs)
Power supply cord	2.0 m (6.6 ft)



Jig Saw Blade, Hex Wrench

M4500KB - Recipro Saw

1,010 W Recipro Saw

M4500KB - Rs. 10,900



303



Continuous rating input	1,010W
Length of Stroke	28 mm (1-1/8")
Strokes Per Minute (SPM)	0 - 2,800
Capacity	Pipe: 130 mm (5-1/8") Wood: 255 mm (10")
Vibration Level	Cutting Boards: 19.5 m/s ² Cutting Wooden Beams: 22.0 m/s ²
Sound Pressure Level	88 dB(A)
Sound Power Level	99 dB(A)
Dimensions (L x W x H)	457x98x174 mm (18"x3-7/8"x6-7/8")
Net weight	3.1 kg (6.9 lbs)
Power supply cord	2.0 m (6.6 ft)



Recipro saw blade set (country-specific), Hex Wrench

Planing/ Routering

M1902B - Power Planer

82 mm (3-1/4") 500 W Planer

M1902B - Rs. 6,800



411



Continuous rating input	500W
Planing Width	82 mm (3-1/4")
Planing Depth	1 mm (1/32")
Max Shiplapping	9 mm (11/32")
No Load Speed (RPM)	16,000
Vibration Level	Planing Softwood: 3.0 m/s ²
Sound Pressure Level	84 dB(A)
Sound Power Level	95 dB(A)
Dimensions (L x W x H)	285x157x160 mm (11-1/4"x6-3/16"x6-5/16")
Net weight	2.7 kg (5.8 lbs)
Power supply cord	2.0 m (6.6 ft)



Planer Blade 82, Sharpening Holder Assembly (for unit with re-sharpenable blade only), Blade Gauge Assembly, Socket Wrench 9, Guide Rule, Dressing stone

Shiplapping: 9mm (11/32")

M3700B - Trimmer

6 mm (1/4") 530 W Fixed Base Trimmer

M3700B - Rs. 5,500



411



Continuous rating input	530W
Collet Capacity	6 mm or 1/4"
No Load Speed (RPM)	35,000
Plunge Capacity	0 - 42 mm (0 - 1-5/8")
Vibration Level	Rotation w/o Load: 2.5 m/s ² or less
Sound Pressure Level	83 dB(A)
Sound Power Level	94 dB(A)
Dimensions (L x W x H)	82x90x199 mm (3-1/4"x3-1/2"x7-7/8")
Net weight	1.4 kg (3.1 lbs.)
Power supply cord	2.0 m (6.6 ft)



Trimmer Guide, Straight Guide Assembly, Templet Guide, Straight Bit, Chip Deflector, Wrench x2

M3601B - Router (Plunge type)

6 mm, 8 mm, 1/4", 3/8" 900 W Plunge Router

M3601B - Rs. 8,900



106



Continuous rating input	900W
Collet Capacity	6 mm, 8 mm or 1/4", 3/8"
Plunge Capacity	0 - 35 mm (0 - 1-3/8")
No Load Speed (RPM)	27,000
Vibration Level	Cutting Grooves in MDF: 7.5 m/s ²
Sound Pressure Level	91 dB(A)
Sound Power Level	102 dB(A)
Dimensions (L x W x H)	256x110x218 mm (10-1/8"x4-5/16"x8-5/8")
Net weight	2.7 kg (6.0 lbs)
Power supply cord	2.0 m (6.6 ft)



Straight Guide, Straight Bit, Collet Cone 8mm, Wrenches

M3600B - Router

12 mm (1/2") 1,650 W Plunge Router

M3600B - Rs. 14,700



211



Continuous rating input	1,650W
Collet Capacity	12 mm or 1/2"
Plunge Capacity	0 - 60 mm (0 - 2-3/8")
No Load Speed (RPM)	22,000
Vibration Level	Cutting Grooves in MDF: 2.5 m/s ²
Sound Pressure Level	86 dB(A)
Sound Power Level	97 dB(A)
Dimensions (L x W x H)	284x148x300 mm (11-1/8"x5-7/8"x11-3/4")
Net weight	5.5 kg (12.2 lbs.)
Power supply cord	2.0 m (6.6 ft)



Straight Guide, Guide Holder Assembly, Collet Sleeve (6 mm or 1/4"), Collet Sleeve (8 mm or 3/8"), Straight Bit, Wrench, Templet Guide 16, Trimmer Guide Assembly, Dust Nozzle

Dust Extraction

M4000B - Blower

530 W Variable Speed Blower

M4000B - Rs. 4,300



85



Continuous rating input	530W
Air volume	1.2-2.9 m ³ /min
No Load Speed (RPM)	8,500 - 16,000
Vibration Level	Operation w/o Load: 2.5 m/s ² or less
Sound Pressure Level	90 dB(A)
Sound Power Level	101 dB(A)
Dimensions (L x W x H)	427x161x212 mm (16-3/4"x6-3/8"x8-3/8")
Net weight	1.5 kg (3.4 lbs)
Power supply cord	2.0 m (6.6 ft)



Nozzle Assembly, Corner Nozzle

Carbon Brush Quick Reference Table

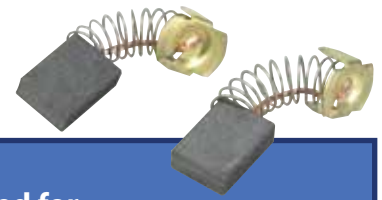

Carbon brush		Economical Type		Model used for
Description	Part No.	Description	Part No.	
JM23000123	JM23000123	-	-	LH1201FL, LS1017L, LH1200FL, MLT100, MT230
CB-51	181021-2	CB-51A	B-80232	4300BV
CB-100	181030-1	CB-100A	B-80298	6906, 9215SB, 9741, JN3200, JS3200
CB-105	181038-5	CB-105A	B-80307	HM0810T, HM0810TA, MT860, M8600
CB-153	181044-0	CB-153A	B-80329	HS0600, LS1016, LS1019L, LS1040, LS1045, LS1216, LS1221, LS1440, MT940, MT941, M9400, N5900B, TW1000, UC3051A, UC3530A, UC3551A, UC4030A, UC4051A, UC4551A, 2012NB, 3501N, 3612BR, 6910, 9105, LS1214, LS1013
CB-155	181048-2	CB-155A	B-80335	HM1202C
CB-106	181410-1	CB-106A	A-81290	MT361, M3601, UT1301, 1911B, 3620
CB-64	191627-8	CB-64A	B-80254	BO3700, BO3710, GD0603, GV5010, JV0600, MT431, MT60, MT620, MT921, MT923, M0600, M4301, M6202, M9201, 4327, 6412, 6413, 906
CB-113	191904-8	-	-	HK0500
CB-411	191940-4	CB-411A	B-80391	JN1601, KP0800, MT190, MT191, MT372, MT430, MT910, MT912, MT954, MT958, MT961, MT963, M1901, M1902, M3700, M4302, M9100, RT0700C, TD0101, TD0101F, TW0200, TW0350, 3709, 6922NB, 9031, MT911
CB-203	191953-5	CB-203A	B-80341	LC1230, LW1400, LW1401, MT240, MT241, MT360, MT362, MT92A, MT92B, M0920, M0921, M2400, M2401, M3600, RP1800, RP2301FC, 2414NB, 3612C
CB-75	191956-9	-	-	GD0603
CB-204	191957-7	CB-204A	B-80357	GA7020, GA7030, GA7040S, GA7050, GA7050R, GA9020, GA9030, GA9040S, GA9050, GA9050R, GS5000, GS6000, HM1306, HM1810, MT902, MT903, PK5011C, SA7000C, VR1000, 4112HS, 4114S, 9617, 9617L, MT900, M0920, MT901
CB-419	191962-4	CB-419A	B-80422	BO4556, BO5031, BO6030, DA3010F, HR2450, HR2440, 4340CT, MT922, DP2010, DP4010, FS2700, HP1620, HP1640, HP2070, HR2020, MT920, MT924, MT925, M9200, M9202, TD0100, UH4261, UH4570, UH4861, UH5261, UH5570, UH6570, 4304, 4350CT, 4304Z, 6826, 6827
CB-303	191963-2	CB-303A	B-80379	CA5000, DA4031, GA5010, HS6600, HS7600, JN3201, JR3050T, JR3070CT, JS3201, MT410, MT411, MT412, MT413, MT450, MT580, MT582, MT583, MT621, MT660, MT904, M0401, M4100, M4101, M4500, M5801, M6200, M6201, M6600, M9002, PV7000C, SP6000, UB1100, UB1102, 2107F, 4100NH2, 4100NH3, 4131, 5740NB, 6924N, 9227C, 9237C, MT40
CB-430	191971-3	-	-	BGA402, BGD800, BGD801, BPB180, BUB360, DGA402, DGD800, DGD801, DHR165, DPB180, DUB361
CB-132	191972-1	-	-	UC3041A, UC3520A, UC3541A, UC4020A, UC4041A
CB-318	191978-9	-	-	GD0801C, GD0810C, GD0811C, PO5000C, PW5001C, SG1251, 9565CVL
CB-85	191998-3	CB-85A	B-80282	HP1630, MT401, MT607, MT653, MT80A, MT80B, MT814, MT817, M0801, M4000, M6501, M8103, MT602, MT811, MT400
CB-434	193466-2	-	-	BFL060F, BFL061F, BFL080F, BFL082F, BFL120F, BFL121F, BFL122F, BFL200F, BFL202F, BFT020F, BFT022F, BFT040F, BFT042F, BFT044F, BFT080F, BFT084F, BFT122F, BFT123F, BFT126F, BTD041, BTD060, BTD061, DFL061F, DFL082F, DFL122F, DFL202F, DFT022F, DFT044F, DFT084F, DFT126F, BTW070, 6918FD
CB-325	194074-2	-	-	GA4040, GA5040R, GD0601, GD0602, HR2230, HR2300, HR2460, HR2470, HR2600, HR2610, HR2611FT, HR2630, HR2650, HR2651, HR2810, M9509, M9511, M9513, 9553B, 9553HN, 9553NB, 9556HB, 9558NB, 9565H
CB-350	194160-9	-	-	HK1820, HM0870C, HM0871C, HR3200C, HR4001C, HR4002, HR4003C, HR4013C
CB-440	194427-5	-	-	BDF458, BFS451, BHP458, BTD143, BTD146, BTS130, BTW110, BTW152, DDF458, DDF482, DHP456, DHP458, DHP482, DTD146, DTS130, DTW152, TD091D, BTD130F, BHP452
CB-441	194435-6	-	-	BHR241, BHS630, BKP140, BKP180, BTW450, DHR202, DHR241, DHS630, DJR186, DKP140, DKP180, DTW450
CB-253	194547-5	-	-	GA5020C, PC5000C, PC5001C
CB-459	194722-3	-	-	GA4030, GA4032, GA4034, GA5030, GA5030R, GA5034, HR1840, JS1000, JS1601, JS1602, MT870, MT90, MT91A, MT960, M0900, M0910, M8700, M8701, M9506, M9508, M9512, PJ7000, TM3000C, TM3010C
CB-442	194928-3	-	-	BUC250, BUH550, BUH650
CB-173	195483-8	-	-	VC2510L, VC3210L
CB-175	195844-2	-	-	HM1101C, HM1203C, HM1205C, HM1213C, HM1214C, HR5202C, HR5212C, HR5201C
CB-448	196854-2	-	-	BTD043, BTD044, BTD063, BTD064, BTD103, BTD104, BTW073, BTW074, BTW103, BTW104, BTW251, BTW253, DTD149, DTD152, DTW251, DTW253
CB-218	197129-2	-	-	HM1802, GA7060, GA7060R, GA7061, GA7061R, GA7062, GA7063R, GA9060, GA9060R, GA9061, GA9061R, HM1812

Product Catalogue

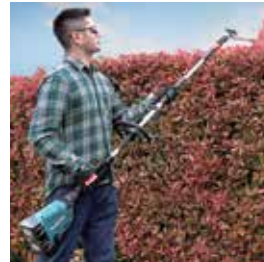

H.O.: Makita Power Tools India Pvt. Ltd.

Unit II Sy. Nos. 93/3 & 93/4, Koralur village,
Kasaba Hobli, Hoskote Taluk, Bengaluru - 560067
Tel: +91-80-2205-8200, Fax: +91-80-2854-9007
Email: sales@makita.in Website: www.makita.in

Makita Service Centre:

Ahmedabad : +91-79-2689-0111
 : +91-79-2689-0920
Chennai : +91-44-2479-2522
Cochin : +91-85904-32003
Delhi : +91-11-4701-4188
 : +91-11-4701-2958
Kolkata : +91-33-2439-1030 / 60
Mumbai : +91-22-4974-4092
Secunderabad : +91-40-4003-8000



LXT AVT MM4
RoHS REACH

Marketed By: