

THREE PHASE INDUCTION MOTOR
GEARED MOTOR

MODEL **SF-JRGD**

The high performance and wide variations meet all needs

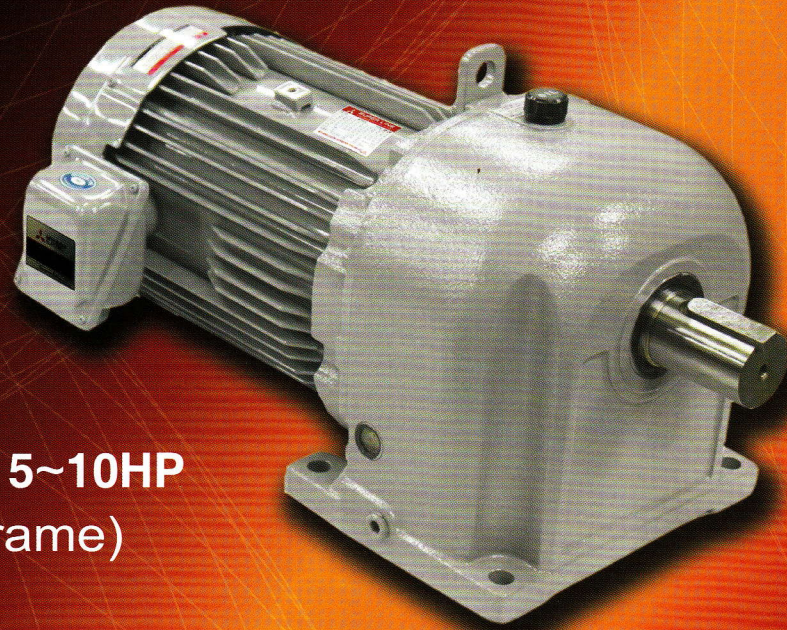

SF-JRGD 5~10HP
(Steel Frame)

- **High Performance Geared Motor,
Applicable to a Wide Range of Industrial Fields**
- **Installation same as GM-D series**
- **IP55 Degrees of Protection**
- **F-Class Insulation**
- **Developed & Made in Thailand,
Gear Set by Mitsubishi Electric FA Industrial Products Corp., Japan**

Introduction

The results of advanced technologies, High-performance geared motor, applicable to a wide range of industrial fields

Geared motor that is indispensable as driving source for FA and exhibit their performance in a wide range of industrial fields, ranging from transportation equipment to food processing equipment. Mitsubishi gear is highly appreciated for their high capabilities, low noise level and compact & durable body that appropriate to the FA age.

Features

Sealing

Hydrodynamic aided rotary shaft lip seals are provided for high-frequency driving to improve sealing quality up to 100 times in comparison with before.

Compact and lightweight

High performance cooling structure of steel motor frame integrated with RGC. (Round-bar Gear Cutting: gear cutting after heat treatment) technology and precision cutting, make the product to be compact and lightweight, suitable for install with limited space machine.

Low noise

From RGC technology and the precision cutting to pinion gear (1st gear) and 2nd gear grinding, realized to low noise operation.

Ecology

Has no 6 hazardous restricted substances which defined in European RoHS directive.

Easy use

By Tapped shaft end and extremely safe terminal box (terminal base), easier sprocket fix and wiring. Developed grease seal capability by improved construction, dimension and oil seal material.

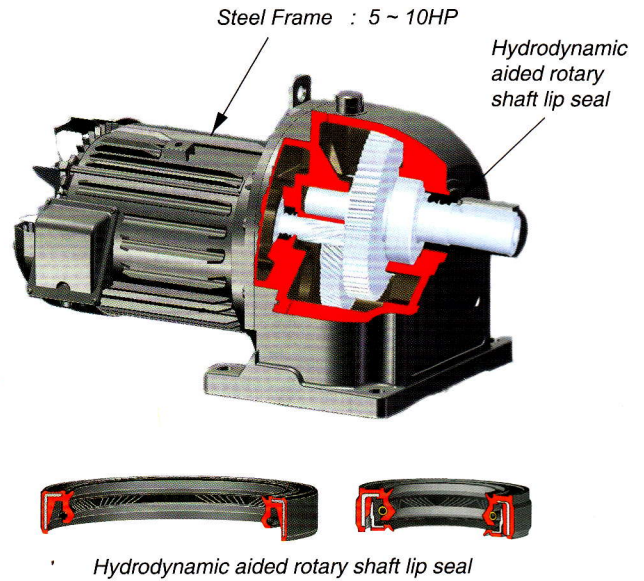

Product code nomenclature

SF-JR GD

└── MITSUBISHI's Gear, D-Series
└── Three Phase Induction Motor, Super Line J-Series

SUPER LINE									
THREE PHASE INDUCTION MOTOR									
5 HP (3.7 kW) 4 POLE					TYPE SF-JRGD				
Hz	50	50	50	60	60	RATIO	1/30		
V	220	380	415	220	440	RATING	S1		
A	13.3	7.7	7.3	13.0	6.6	TH.CLASS	155(F)		
min ⁻¹	50	50	50	60	61	IP55	IC411		
PF	0.88	0.88	0.85	0.90	0.87	IEC 60034-1 JEC-2137-2000 SERIAL			

MITSUBISHI ELECTRIC AUTOMATION (THAILAND) CO.,LTD.
NM14N169-07
Sample name plate model : SF-JRGD 5HP(3.7kW) 4P **LT** ratio 1/30

SUPER LINE									
THREE PHASE INDUCTION MOTOR									
5 HP (3.7 kW) 4 POLE					TYPE SF-JRGD				
Hz	50	50	60	60	RATIO	1/30			
V	380	415	380	440	RATING	S1			
A	8.2	7.5	8.4	7.1	TH.CLASS	155(F)			
min ⁻¹	50	50	58.5	61	IP55	IC411			
PF	0.88	0.84	0.90	0.87	IEC 60034-1 JEC-2137-2000 SERIAL				

MITSUBISHI ELECTRIC AUTOMATION (THAILAND) CO.,LTD.
NM14N205-07
Sample name plate model : SF-JRGD 5HP(3.7kW) 4P **HT** ratio 1/30

Ordering

When making an order or an inquiry, please prepare these following basic specifications.

	Model name	Output	Gear ratio (or speed)	Voltage	Frequency
EX.	SF-JRGD	5HP (3.7kW)	1/30 or 50 min ⁻¹ *	220V or 380V	50Hz or 60Hz

Load condition for service factor selection

Table 1 - Load condition

Service factor	Load condition		
	3 hrs./day discontinuous operation	3 ~ 10 hrs./day continuous operation	Over 10 hrs./day continuous operation
1.4	Heavy shock load	Moderate shock load	Constant or low shock

* Remark : min⁻¹ = r/min or rpm (Revolutions per minute)

Stock & delivery (Gear ratio : 1/3 ~ 1/60)

Table 2 - Gear size and stock & delivery

Output shaft rotation speed (min ⁻¹)	50Hz	500	300	150	100	75	60	50	37.5	30	25
	60Hz	600	360	180	120	90	72	60	45	36	30
Gear ratio		1/3	1/5	1/10	1/15	1/20	1/25	1/30	1/40	1/50	1/60
Output HP(kW)	5(3.7)	○ L	● L	● L	● L	● L	○ L	● L	● M	○ M	○ N
	7.5(5.5)	○ M	● M	● M	● M	● M	○ M	● M	● N	○ N	
	10(7.5)	○ M	● M	● M	● M	● M	○ N	● N			

- In stock
- Upon request and delivery within 30 days

- Grease lubricant type
- Oil lubricant type
- Gear size

Note : For output 1/2~3HP(0.4~ 2.2kW), please see catalog model **MET-TGD**

Remark : For gear ratio no identify in Table2, please consult us before order

Standard Specifications

Table 3 - Standard specifications

Item	Standard specifications
Output	5HP(3.7kW), 7.5HP(5.5kW), 10HP(7.5kW)
Pole	4
Phase	3 phase
Voltage / Frequency *	LT : 220/380 ~ 415V 50Hz , 220/440V 60Hz HT : 380~415V 50Hz , 380~440V 60Hz
Gear Ratio	1/3 ~ 1/60 (7.5HP : 1/3~1/50, 10HP : 1/3~1/30)
Rating	S1 (continuous)
Insulation Class	F(155° C)
Starting	Direct , Y - Δ
Casting Construction	Totally-enclosed fan-cooled
Protective Construction	Outdoor (IP55)
Mounting	Foot mount
Frame Material	Steel
Mounting Direction	Grease lubrication type : Universal direction / Oil lubrication type : Limited (see page 4)
Ambient Temperature	-15 ~ +40 °C (No freezing)
Ambient Humidity	90% RH or less
Elevation	up to 1,000 meters above sea level
Vibration	4.9 m/s ² or less constantly, 9.8 m/s ² or less instantaneously
Lubrication	5HP (1/3~1/30) : Grease lubrication (Pyroknock Universal#000) 5HP(1/40~1/60), 7.5,10HP : Oil lubrication (no filled oil from factory)
Service Factor	1.4 (reduction gear)
Conformative Standard	IEC 60034-1, JEC-2137-2000
Paint	Munsell N5.5 (gray)
Accessories	Shaft end key (JIS B 1301-1996)

Output shaft rotation direction

Output shaft rotation direction is as shown in Table 4 (when power supply is connected as shown in Table 5)

Table 4 - Output shaft rotation direction

Output HP(kW)	Gear ratio	Step No. of Gear	Rotation direction
5(3.7)	1/3	3	Clockwise
	1/5 ~ 1/30	2	Counterclockwise
	1/40 ~ 1/60	3	Clockwise
7.5(5.5)	1/3 ~ 1/30	2	Counterclockwise
	1/40, 1/50	3	Clockwise
10(7.5)	1/3 ~ 1/30	2	Counterclockwise

* Remark : LT = Low voltage, HT = High voltage

Wiring

Connect power supply to terminal as shown in Table 5. To rotate in opposite direction, swap any pair of wires (from R, S, and T).

Table 5 - Standard wiring

OUTPUT HP(kW)	TERMINAL CONNECTOR & WIRE CONNECTION METHOD		
	DIRECT START		Y-Δ START
	220V (Δ)	380~440V (Y)	220V
5~10 (3.7~7.5) LT			
5~10 (3.7~7.5) HT	<p>DIRECT START</p> <p>380~440V</p>		<p>Y-Δ START</p> <p>380~440V</p>

Lubrication details

- (1) For grease lubrication type, grease is filled from factory. For ambient temperature between -15°C to +40°C, lithium soap grease (extreme pressure) NLGI No.000 is applicable. Grease lubrication type can be installed in universal direction.
- (2) For the oil lubrication type, no filled oil from factory shipment. Select appropriate oil type and quantity by refer to Table 6-7. Before operation, oil level must be above red line on oil level gauge. Do not overfill, doing so can cause to leak or overheat. Allowable inclination for horizontal installation is as shown in Table 8.

Table 6 - Oil lubrication type

Ambient temp.	-15 ~ 0 °C	0 ~ 40 °C	40 ~ 70 °C
JIS	Class 2 ISO VG150	Class 2 ISO VG220	Class 2 ISO VG320
Nippon oil	Bonnoc M 150	Bonnoc M 220	Bonnoc M 320
Showa shell oil	Shell omala oil 150	Shell omala oil 220	Shell omala oil 320
General oil	General SP gearroll 150	General SP gearroll 220	General SP gearroll 320
Mobil oil	Mobil gear 629	Mobil gear 630	Mobil gear 632
Cosmo oil	Cosmogear SE-150	Cosmogear SE-220	Cosmogear SE-320

Table 7 - Lubricant Quantity

Output shaft speed (min ⁻¹)	50Hz	500	300	150	100	75	60	50	37.5	30	25
	60Hz	600	360	180	120	90	72	60	45	36	30
Gear ratio	1/3	1/5	1/10	1/15	1/20	1/25	1/30	1/40	1/50	1/60	
Output HP(kW)	5(3.7)				3.2				2.0	3.3	
	7.5(5.5)				2.0				3.3		
	10(7.5)				2.0		3.3				

- Grease Quantity(kg)
- Oil Quantity(litre)

Note : For oil lubrication type, "Shell omala oil 320" will be supported from our factory by 4 litre.

Table 8 - Allowable installation inclination

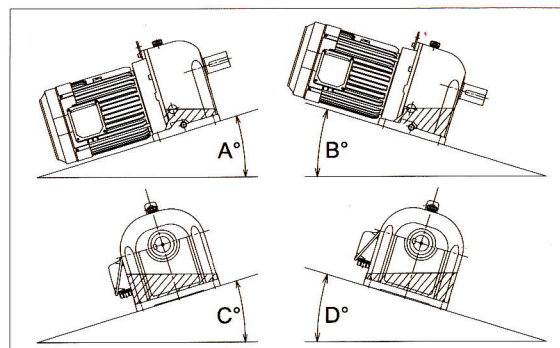

Gear size	A°	B°	C°	D°
M	14	17	17	17
N	13	17	16	16

Motor characteristics

Table 9 - Motor characteristic for 5~10HP (3.7~ 7.5kW) LT : 220/380 ~ 415V 50Hz , 220/440V 60Hz

Output HP(kW)	Output shaft rotation speed (min ⁻¹)					Round up gear ratio	Actual gear ratio	Output shaft allowable torque (Nm)					Output shaft allowable overhanging load (N)	Output shaft allowable thrust load (N)	Motor specification			
	50Hz		60Hz					50Hz		60Hz					V	Hz	A	
	220	380	415	220	440			220	380	415	220	440						
5(3.7)	480	480	485	575	585	1/3	1/2.95	73	73	73	61	60	2700	130	↑	↑	↑	
	295	295	300	355	365	1/5	1/4.75	118	118	117	99	97	3190	217				
	142	142	143	170	173	1/10	1/9.97	248	248	246	207	204	4900	433				
	99	99	99	118	120	1/15	1/14.35	357	357	355	298	293	5590	650	220	50	13.3	
	70	70	70.5	84	85.5	1/20	1/20.22	503	503	500	420	413	6960	867	380	50	7.7	
	56.5	56.5	57	67.5	68.5	1/25	1/25.13	626	626	621	532	513	8870	1083	415	50	7.3	
	50	50	50	60	61	1/30	1/28.41	707	707	702	591	581	10780	1300	220	60	13.0	
	34.5	34.5	34.5	41	42	1/40	1/41.13	1024	1024	1017	855	840	10190	1400	440	60	6.6	
	30	30	30	36	36.5	1/50	1/47.26	1177	1177	1168	983	966	13430	1400	↓	↓	↓	
23	23	23	27.5	27.5	1/60	1/62.12	1546	1546	1536	1292	1269	18330	2200					
7.5(5.5)	490	490	495	580	590	1/3	1/2.91	107	107	106	90	88	3480	140	↑	↑	↑	
	290	290	295	345	350	1/5	1/4.89	180	180	178	151	149	4120	233				
	150	150	151	178	181	1/10	1/9.51	349	349	347	294	289	6370	467				
	101	101	102	121	123	1/15	1/14.05	516	516	513	434	427	8620	700	220	50	20.1	
	76.5	76.5	77	91	92.5	1/20	1/18.63	685	685	680	576	566	9800	933	380	50	11.6	
	61.5	61.5	62	73	74.5	1/25	1/23.22	853	853	847	718	705	11270	1167	415	50	11.3	
	47.5	47.5	47.5	56.5	57.5	1/30	1/30.10	1106	1106	1098	930	914	12740	1400	220	60	19.5	
	37.5	37.5	37.5	44.5	45.5	1/40	1/38.12	1401	1401	1391	1178	1158	14110	2200	440	60	9.9	
	29	29	29.5	35	35.5	1/50	1/48.78	1792	1792	1780	1508	1482	15580	2200	↓	↓	↓	
10(7.5)	495	495	500	595	605	1/3	1/2.87	144	144	143	120	118	3920	210	↑	↑	↑	
	285	285	285	340	340	1/5	1/4.99	250	250	248	209	211	4610	350				
	145	145	146	173	176	1/10	1/9.86	494	494	491	413	406	7150	700				
	100	100	101	120	122	1/15	1/14.22	713	713	708	596	586	10190	1050	380	50	15.5	
	72	72	72.5	86.5	88	1/20	1/19.78	991	991	984	829	815	11560	1400	415	50	15.2	
	59	59	59.5	70.5	72	1/25	1/24.20	1213	1213	1204	1014	997	13720	1833	220	60	26.0	
	52	52	52.5	62.5	63.5	1/30	1/27.38	1372	1372	1362	1147	1128	15970	2200	440	60	13.3	
																↓	↓	↓

Table 10 - Motor characteristic for 5~10HP (3.7~ 7.5kW) HT : 380~415V 50Hz , 380~440V 60Hz

Output HP(kW)	Output shaft rotation speed (min ⁻¹)				Round up gear ratio	Actual gear ratio	Output shaft allowable torque (Nm)				Output shaft allowable overhanging load (N)	Output shaft allowable thrust load (N)	Motor specification			
	50Hz		60Hz				50Hz		60Hz				V	Hz	A	
	380	415	380	440			380	415	380	440						
5(3.7)	480	485	570	585	1/3	1/2.95	73	73	62	60	2700	130	↑	↑	↑	
	295	300	350	365	1/5	1/4.75	118	117	100	97	3190	217				
	142	143	165	173	1/10	1/9.97	248	246	210	204	4900	433				
	99	99	115	120	1/15	1/14.35	357	355	302	293	5590	650	380	50	8.2	
	70	70.5	80	85.5	1/20	1/20.22	503	500	425	413	6960	867	415	50	7.5	
	56.5	57	66.5	68.5	1/25	1/25.13	626	621	529	513	8870	1083	380	60	8.4	
	50	50	58.5	61	1/30	1/28.41	707	702	598	581	10780	1300	440	60	7.1	
	34.5	34.5	40.5	42	1/40	1/41.13	1024	1017	865	840	10190	1400	↓	↓	↓	
	30	30	35.5	36.5	1/50	1/47.26	1177	1168	994	966	13430	1400				
23	23	27	27.5	1/60	1/62.12	1546	1536	1307	1269	18330	2200					
7.5(5.5)	490	495	585	590	1/3	1/2.91	107	106	89	88	3480	140	↑	↑	↑	
	290	295	345	350	1/5	1/4.89	180	178	150	149	4120	233				
	150	151	180	181	1/10	1/9.51	349	347	292	289	6370	467				
	101	102	120	123	1/15	1/14.05	516	513	432	427	8620	700	380	50	12.2	
	76.5	77	91.5	92.5	1/20	1/18.63	685	680	572	566	9800	933	415	50	11.8	
	61.5	62	73.5	74.5	1/25	1/23.22	853	847	714	705	11270	1167	380	60	12.3	
	47.5	47.5	56.5	57.5	1/30	1/30.10	1106	1098	925	914	12740	1400	440	60	10.7	
	37.5	37.5	44.5	45.5	1/40	1/38.12	1401	1391	1171	1158	14110	2200	↓	↓	↓	
	29	29.5	35	35.5	1/50	1/48.78	1792	1780	1499	1482	15580	2200				
10(7.5)	495	500	595	605	1/3	1/2.87	144	143	120	118	3920	210	↑	↑	↑	
	285	285	340	340	1/5	1/4.99	250	248	209	211	4610	350				
	145	146	173	176	1/10	1/9.86	494	491	413	406	7150	700				
	100	101	120	122	1/15	1/14.22	713	708	596	586	10190	1050	380	50	16.3	
	72	72.5	86.5	88	1/20	1/19.78	991	984	829	815	11560	1400	415	50	15.3	
	59	59.5	70.5	72	1/25	1/24.20	1213	1204	1014	997	13720	1833	380	60	16.3	
	52	52.5	62.5	63.5	1/30	1/27.38	1372	1362	1128	1128	15970	2200	440	60	14.1	
														↓	↓	↓

Outline dimensions

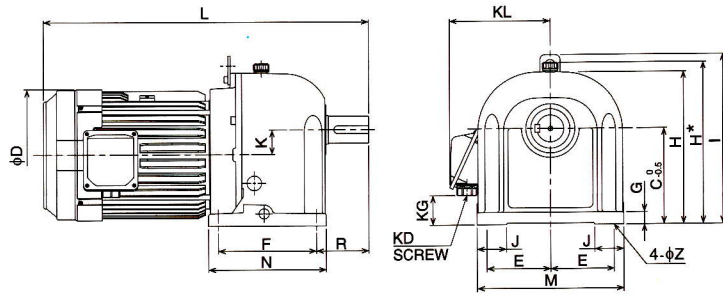

Table 11 - Outline dimensions

Output HP(kW)	Gear ratio	Gear size	Dimensions (mm)																	Weight (kg)
			L	φD	K	F	R	N	KD	KL	KG	J	E	M	G	C	H	I	φZ	
5(3.7)	1/3~1/30	L	568	226	40	170	95	206	PF3/4	176	63	50	125	285	22	170	275	310	15	82.0
	1/40, 1/50	M	609	226	50	200	107	240	PF3/4	176	78	60	130	300	25	195	330*	345	19	99.0
	1/60	N	642.5	226	60	230	120	280	PF3/4	176	103	70	150	350	30	230	380*	395	24	126.2
7.5(5.5)	1/3~1/30	M	663.5	266	50	200	107	240	PF1	205	60	60	130	300	25	195	330*	345	19	105.5
	1/40, 1/50	N	697	266	60	230	120	280	PF1	205	85	70	150	350	30	230	380*	395	24	140
10(7.5)	1/3~1/20	M	701.5	266	50	200	107	240	PF1	205	60	60	130	300	25	195	330*	345	19	120.5
	1/25, 1/30	N	720	266	60	230	120	280	PF1	205	85	70	150	350	30	230	380*	395	24	141.5

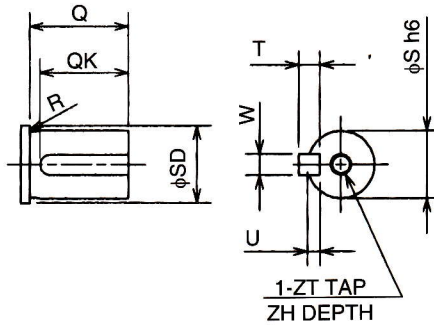

Table 12 - Shaft end dimensions

Gear size	Dimensions (mm)											
	Q	QK	φS h6	W(key) h9	T(key) h9	U	ZT	ZH	R	φSD		
D	36	32	22 ⁰ _{-0.013}	6	6 ⁰ _{-0.030}	3.5	M8	12	0.4	24		
F	50	45	32	10	8 ⁰ _{-0.036}	5					0.8	34
G												
H												
J	60	55	40 ⁰ _{-0.016}	12	8	5	M10	18	0.8	45		
L	75	70	48	14	9 ⁰ _{-0.043}	5.5					50	
M	82	71	55	16	10	6						58
N	90	72	60	18	11	7					63	

MITSUBISHI ELECTRIC AUTOMATION (THAILAND) CO., LTD.



for a greener tomorrow

Eco Changes is the Mitsubishi Electric Group's environmental statement, and expresses the Group's stance on environmental management. Through a wide range of businesses, we are helping contribute to the realization of a sustainable society.

