

MEATH

THREE PHASE INDUCTION MOTOR
GEARED MOTOR

MODEL **MET-TGD**

The high performance and wide variations meet all needs

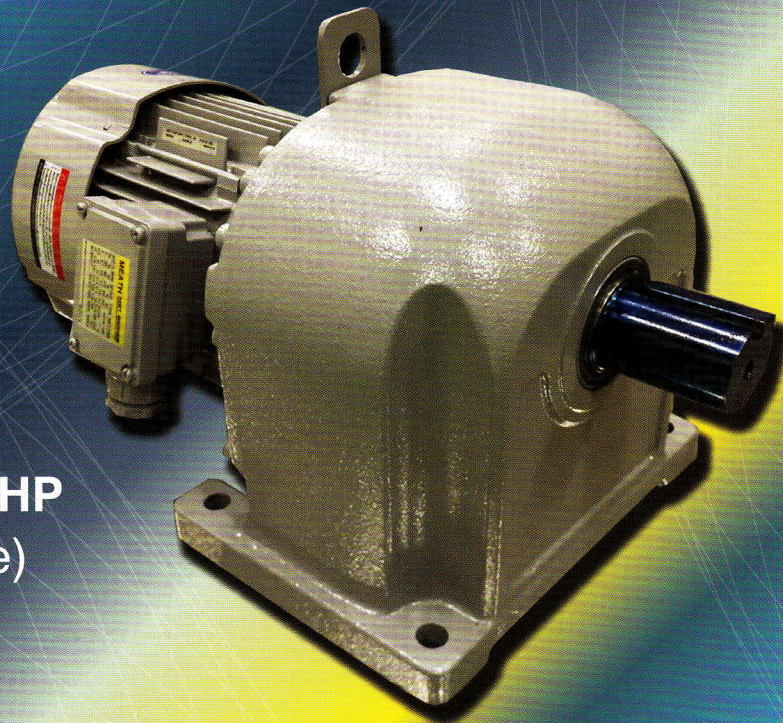

MET-TGD 1/2 ~ 3HP
(Aluminium Frame)

- High Performance Geared Motor,
Applicable to a Wide Range of Industrial Fields
- Installation same as GM-D series
- IP55 Degrees of Protection
- F-Class Insulation
- Developed & Made in Thailand,
Gear Set by Mitsubishi Electric FA Industrial Products Corp., Japan

Introduction

The results of advanced technologies, High-performance geared motor, applicable to a wide range of industrial fields

Geared motor that is indispensable as driving source for FA and exhibit their performance in a wide range of industrial fields, ranging from transportation equipment to food processing equipment. Mitsubishi gear is highly appreciated for their high capabilities, low noise level and compact & durable body that appropriate to the FA age.

Features

Sealing

Hydrodynamic aided rotary shaft lip seals are provided for high-frequency driving to improve sealing quality up to 100 times in comparison with before.

Compact and lightweight

High performance cooling structure of aluminum alloy motor frame integrated with RGC. (Round-bar Gear Cutting: gear cutting after heat treatment) technology and precision cutting, make the product to be compact and lightweight, suitable for install with limited space machine.

Low noise

From RGC technology and the precision cutting to pinion gear (1st gear) and 2nd gear grinding, realized to low noise operation.

Ecology

Has no 6 hazardous restricted substances which defined in European RoHS directive.

Easy use

By Tapped shaft end and extremely safe terminal box (terminal base), easier sprocket fix and wiring. Developed grease seal capability by improved construction, dimension and oil seal material.

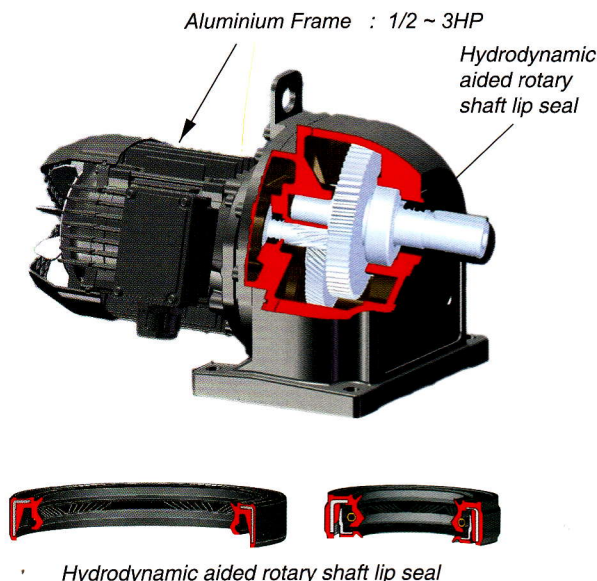

Product code nomenclature

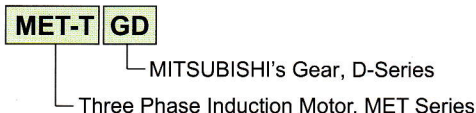

MEATHMET SERIES									
THREE PHASE INDUCTION MOTOR									
1HP (0.75kW) 4POLE TYPE MET-TGD									
Hz	50	50	50	60	60	RATIO	1/30		
V	220	380	415	220	440	RATING	S1		
A	3.50	2.00	2.15	3.20	1.77	TH.CLASS	155(F)		
min ⁻¹	50	50	50.5	60	61	IP55	IC411		
PF	0.80	0.79	0.70	0.85	0.77	SERIAL			
IEC60034-1	JEC-2137-2000								
MITSUBISHI ELECTRIC AUTOMATION (THAILAND) CO., LTD.									
NMB4N166-07									

Sample name plate model :
MET-TGD 1HP(0.75kW) 4P LT ratio 1/30

Ordering

When making an order or an inquiry, please prepare these following basic specifications.

Model name	Output	Gear ratio (or speed)	Voltage	Frequency
EX. MET-TGD	1HP(0.75kW)	1/30 or 50 min ⁻¹ *	220V or 380V	50Hz or 60Hz

Load condition for service factor selection

Table 1 - Load condition

Service factor	Load condition		
	3 hrs./day discontinuous operation	3 ~ 10 hrs./day continuous operation	Over 10 hrs./day continuous operation
1.4	Heavy shock load	Moderate shock load	Constant or low shock

* Remark : min⁻¹ = r/min or rpm (Revolutions per minute)

Stock & delivery (Gear ratio : 1/3 ~ 1/60)

Table 2 - Gear size and stock & delivery

Output shaft rotation speed (min ⁻¹)	50Hz	500	300	150	100	75	60	50	37.5	30	25
	60Hz	600	360	180	120	90	72	60	45	36	30
Gear ratio		1/3	1/5	1/10	1/15	1/20	1/25	1/30	1/40	1/50	1/60
Output HP(kW)	1/2(0.4)	○ D	● D	● D	● D	● D	● D	● D	● D	● D	○ G
	1(0.75)	○ F	● F	● F	● F	● F	● F	● F	● G	● G	○ J
	2(1.5)	○ H	● H	● H	● H	● H	● H	● H	● J	● J	○ L
	3(2.2)	○ J	● J	● J	● J	● J	● J	● J	● L	● L	○ M

- In stock
- Upon request and delivery within 30 days

- Grease lubricant type
- Oil lubricant type
- Gear size

Note : For output 5~10HP(3.7~ 7.5kW), please see catalog model **SF-JRGD**

Remark : For gear ratio no identify in Table2, please consult us before order

Standard Specifications

Table 3 - Standard specifications

Item	Standard specifications
Output	1/2HP(0.4kW), 1HP(0.75kW), 2HP(1.5kW), 3HP(2.2kW)
Pole	4
Phase	3 phase
Voltage / Frequency *	LT : 220/380 ~ 415V 50Hz , 220/440V 60Hz
Gear Ratio	1/3 ~ 1/60
Rating	S1 (continuous)
Insulation Class	F (155 °C)
Starting	Direct
Casting Construction	Totally-enclosed fan-cooled
Protective Construction	Outdoor (IP55)
Mounting	Foot mount
Frame Material	Aluminium
Mounting Direction	Grease lubrication type : Universal direction / Oil lubrication type : Limited (see page 4)
Ambient Temperature	-15 ~ +40 °C (No freezing)
Ambient Humidity	90% RH or less
Elevation	up to 1,000 meters above sea level
Vibration	4.9 m/s ² or less constantly, 9.8 m/s ² or less instantaneously
Lubrication	1/2~ 3HP : Grease lubrication (Pyroknock Universal#000) 3HP(1/60): Oil lubrication (no filled oil from factory)
Service Factor	1.4 (reduction gear)
Conformative Standard	IEC 60034-1, JEC-2137-2000
Paint	Munsell N5.5 (gray)
Accessories	Shaft end key (JIS B 1301-1996)

Output shaft rotation direction

Output shaft rotation direction is as shown in Table 4 (when power supply is connected as shown in Table 5)

Table 4 - Output shaft rotation direction

Output HP(kW)	Gear ratio	Step No. of Gear	Rotation direction
1/2(0.4)	1/3 ~ 1/50	2	Counterclockwise
	1/60	3	Clockwise
1(0.75)	1/3 ~ 1/30	2	Counterclockwise
	1/40 ~ 1/60	3	Clockwise
2(1.5)	1/3 ~ 1/30	2	Counterclockwise
	1/40 ~ 1/60	3	Clockwise
3(2.2)	1/3 ~ 1/30	2	Counterclockwise
	1/40 ~ 1/60	3	Clockwise

* Remark : LT = Low voltage

Wiring

Connect power supply to terminal as shown in Table 5. To rotate in opposite direction, swap any pair of wires (from R, S, and T).

Table 5 - Standard wiring

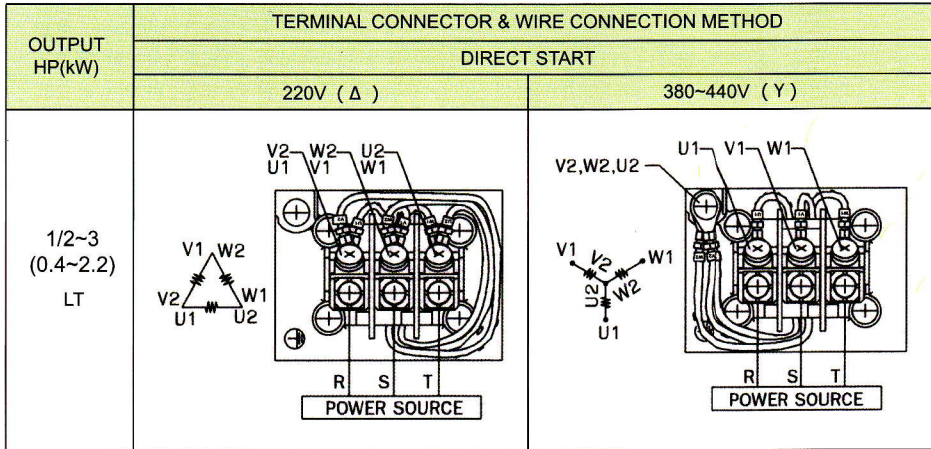

Lubrication details

- (1) For grease lubrication type, grease is filled from factory. For ambient temperature between -15°C to +40°C, lithium soap grease (extreme pressure) NLGI No.000 is applicable. Grease lubrication type can be installed in universal direction.
- (2) For the oil lubrication type, no filled oil from factory shipment. Select appropriate oil type and quantity by refer to Table 6-7. Before operation, oil level must be above red line on oil level gauge. Do not overfill, doing so can cause to leak or overheat. Allowable inclination for horizontal installation is as shown in Table 8.

Table 6 - Oil lubrication type

Ambient temp.	-15 ~ 0 °C	0 ~ 40 °C	40 ~ 70 °C
JIS	Class 2 ISO VG150	Class 2 ISO VG220	Class 2 ISO VG320
Nippon oil	Bonnoc M 150	Bonnoc M 220	Bonnoc M 320
Showa shell oil	Shell omala oil 150	Shell omala oil 220	Shell omala oil 320
General oil	General SP gearroll 150	General SP gearroll 220	General SP gearroll 320
Mobil oil	Mobil gear 629	Mobil gear 630	Mobil gear 632
Cosmo oil	Cosmogear SE-150	Cosmogear SE-220	Cosmogear SE-320

Table 7 - Lubricant Quantity

Output shaft speed (min ⁻¹)	50Hz	500	300	150	100	75	60	50	37.5	30	25	
	60Hz	600	360	180	120	90	72	60	45	36	30	
Gear ratio	1/3	1/5	1/10	1/15	1/20	1/25	1/30	1/40	1/50	1/60		
Output HP(kW)	1/2(0.4)	0.52					0.42					1.0
	1(0.75)	0.9					1.0					2.1
	2(1.5)	1.5					2.1					2.7
	3(2.2)	2.1					2.7					2.0

- Grease Quantity(kg)
- Oil Quantity(litre)

Note : For oil lubrication type, "Shell omala oil 320" will be supported from our factory by 4 litre.

Table 8 - Allowable installation inclination

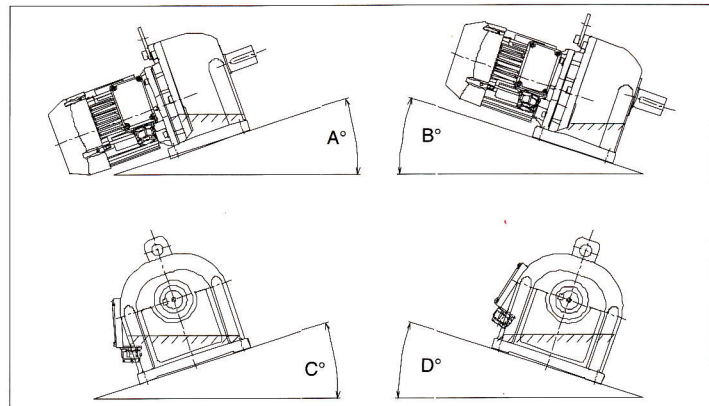

Gear size	A°	B°	C°	D°
M	14	17	17	17

Motor characteristics

Table 9 - Motor characteristic for 1/2~3HP (0.4~ 2.2kW) LT : 220/380 ~ 415V 50Hz , 220/440V 60Hz

Output HP(kW)	Output shaft rotation speed (min ⁻¹)					Round up gear ratio	Actual gear ratio	Output shaft allowable torque (Nm)					Output shaft allowable overhanging load (N)	Output shaft allowable thrust load (N)	Motor specification		
	50Hz			60Hz				50Hz			60Hz				V	Hz	A
	220	380	415	220	440			220	380	415	220	440					
1/2(0.4)	470	470	470	565	570	1/3	1/3.00	8.1	8.1	8.1	6.7	6.7	686	50	↑	↑	↑
	285	285	285	345	345	1/5	1/4.92	13	13	13	11	11	784	83			
	142	142	143	171	172	1/10	1/9.94	27	27	27	22	22	1180	167			
	95	95	96	115	115	1/15	1/14.80	40	40	40	33	33	1370	250	220	50	2.00
	73.5	73.5	74	89	89.5	1/20	1/19.10	52	52	51	43	43	1570	333	380	50	1.15
	55	55	55.5	66.5	67	1/25	1/25.54	69	69	69	57	57	1670	417	415	50	1.30
	46.5	46.5	47	56.5	56.5	1/30	1/30.15	82	82	81	68	67	1810	500	220	60	1.85
	35	35	35	42	42.5	1/40	1/40.20	109	109	108	90	90	1960	500	440	60	1.05
	28	28	28	33.5	33.5	1/50	1/50.62	137	137	136	114	113	2450	500	↓	↓	↓
	23.5	23.5	23.5	28	28.5	1/60	1/60.06	163	163	162	135	134	3230	700	↓	↓	↓
1(0.75)	460	460	465	550	560	1/3	1/3.04	16	16	15	13	13	980	70	↑	↑	↑
	290	290	295	350	355	1/5	1/4.80	25	25	24	20	20	1180	117			
	140	140	143	169	172	1/10	1/9.94	51	51	50	42	42	1760	233			
	96	96	97	115	117	1/15	1/14.58	75	75	74	62	61	1960	350	220	50	3.50
	71.5	71.5	72.5	85.5	87	1/20	1/19.59	100	100	99	84	82	2650	467	380	50	2.00
	55	55	56	66	67.5	1/25	1/25.38	130	130	128	108	106	2790	583	415	50	2.15
	50	50	50.5	60	61	1/30	1/27.96	143	143	141	119	117	2990	700	220	60	3.20
	37	37	37.5	44	45	1/40	1/37.93	194	194	191	162	159	3040	700	440	60	1.77
	29.5	29.5	30	35.5	36	1/50	1/47.39	243	243	239	202	199	4020	700	↓	↓	↓
	23	23	23.5	28	28.5	1/60	1/60.20	308	308	304	257	252	4310	1200	↓	↓	↓
2(1.5)	480	480	485	580	585	1/3	1/2.93	30	30	30	25	24	1320	70	↑	↑	↑
	285	285	290	345	350	1/5	1/4.91	50	50	50	41	41	1570	117			
	144	144	145	173	176	1/10	1/9.78	99	99	99	82	81	2450	233			
	96	96	97	116	118	1/15	1/14.57	148	148	147	123	121	2940	350	220	50	6.7
	71.5	71.5	72	86	87	1/20	1/19.76	201	201	199	167	165	3920	467	380	50	3.8
	60	60	60.5	66.5	67	1/25	1/23.47	239	239	237	198	196	4460	583	415	50	4.0
	49.5	49.5	50	59.5	60.5	1/30	1/28.42	289	289	287	240	237	5000	700	220	60	6.5
	34.5	34.5	35	41.5	42	1/40	1/40.67	413	413	410	343	339	5190	1200	440	60	3.4
	31	31	31.5	37.5	38	1/50	1/45.19	459	459	465	381	377	6370	1200	↓	↓	↓
	25	25	25	30	30.5	1/60	1/56.45	574	574	570	476	470	8820	1300	↓	↓	↓
3(2.2)	465	465	470	560	565	1/3	1/3.04	45	45	45	38	37	1910	120	↑	↑	↑
	285	285	285	340	345	1/5	1/5.00	74	74	73	62	61	2250	200			
	142	142	143	171	172	1/10	1/9.98	148	148	147	123	122	3430	400			
	97	97	98	117	118	1/15	1/14.52	215	215	213	180	177	3920	600	220	50	8.5
	75	75	75.5	89.5	90.5	1/20	1/18.92	280	280	278	234	231	5100	800	380	50	4.9
	61	61	61.5	73	74	1/25	1/23.19	343	343	341	287	283	5640	1000	415	50	5.0
	48	48	48.5	57.5	58.5	1/30	1/29.36	435	435	432	363	359	6220	1200	220	60	7.8
	36	36	36.5	43.5	44	1/40	1/39.16	580	580	576	484	479	6370	1300	440	60	4.3
	31.5	31.5	31.5	37.5	38	1/50	1/44.95	665	665	661	556	549	7840	1300	↓	↓	↓
	24	24	24	28.5	29	1/60	1/59.51	881	881	875	736	727	14700	1400	↓	↓	↓

THREE PHASE INDUCTION MOTOR, GEARED MOTOR

Outline dimensions

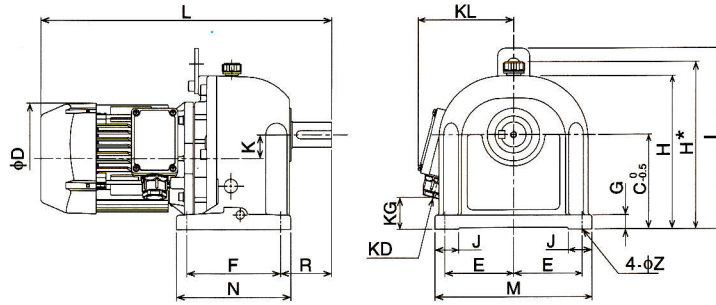

Table 10 - Outline dimensions

Output HP(kW)	Gear ratio	Gear size	Dimensions (mm)																	Weight (kg)
			L	ϕD	K	F	R	N	KD	KL	KG	J	E	M	G	C	H	I	ϕZ	
1/2(0.4)	1/3~1/50	D	293	142	20	85	50	109	PF1/2	122	31	25	75	170	15	100	160	-	10	9.0
	1/60	G	347	142	30	135	65	161	PF1/2	122	46	30	87.5	200	18	125	195	230	12	22.5
1(0.75)	1/3~1/30	F	371	142	30	120	65	146	PF3/4	122	40.5	30	87.5	200	18	120	195	230	12	23.0
	1/40, 1/50	G	389.5	142	30	135	65	161	PF3/4	122	45.5	30	87.5	200	18	125	195	230	12	27.0
	1/60	J	422.5	142	32	150	80	187	PF3/4	122	63.5	45	107.5	250	22	145	230	265	15	38.5
2(1.5)	1/3~1/30	H	410.5	172	30	115	65	141	PF3/4	133.5	63.5	35	102.5	230	18	140	227	262	12	33.5
	1/40, 1/50	J	450	172	32	150	80	187	PF3/4	133.5	66.5	45	107.5	250	22	145	230	265	15	44.0
	1/60	L	476.5	172	40	170	95	206	PF3/4	133.5	83.5	50	125	285	22	170	275	310	15	58.0
3(2.2)	1/3~1/30	J	500	180	32	150	80	187	PF3/4	133.5	66.5	45	107.5	250	22	145	230	265	15	46.0
	1/40, 1/50	L	526	180	40	170	95	206	PF3/4	133.5	83.5	50	125	285	22	170	275	310	15	62.5
	1/60	M	568.5	180	50	200	107	240	PF3/4	133.5	98.5	60	130	300	25	195	330*	345	19	79.5

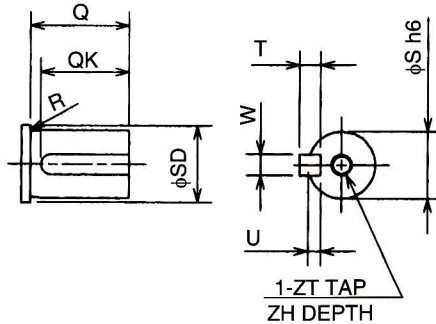

Table 11 - Shaft end dimensions

Gear size	Dimensions (mm)										
	Q	QK	$\phi S h6$	W(key) h9	T(key) h9	U	ZT	ZH	R	ϕSD	
D	36	32	22	$6^{0/-0.013}$	$6^{0/-0.030}$	3.5			0.4	24	
F	50	45	32	10	$8^{0/-0.036}$	5	M8	12	0.8	34	
G											
H	60	55	40	12	8	5			1.6	45	
J											
L	75	70	48	14	$9^{0/-0.043}$	5.5			0.8	50	
M											
N	90	72	60	16	10	6	M10	18	0.8	58	
			18	11	7	63					

MITSUBISHI ELECTRIC AUTOMATION (THAILAND) CO., LTD.