

# CYCLO DRIVE 6000 SERIES

SUMITOMO CYCLO-DRIVE WITH  
MITSUBISHI ELECTRIC MOTOR

**...ABSORB 500% SHOCK LOAD  
WITHOUT DAMAGE!**

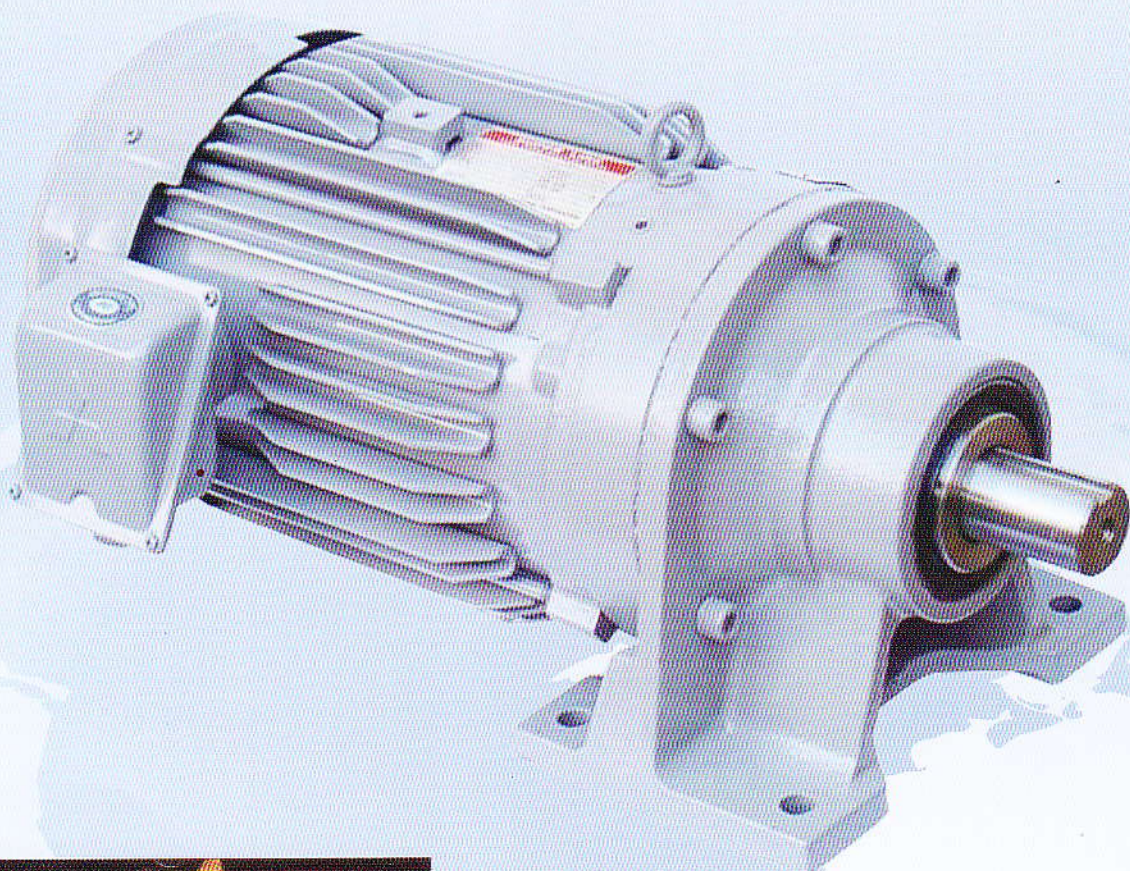

**SUMITOMO CYCLO DRIVE  
500% SHOCK LOAD  
VISUAL PROOF!**



## PRODUCT FEATURES AND BENEFITS

**CYCLO DRIVE® Brilliant engineering with unmatched performance advantages**

### 500% OVER SHOCK LOAD

This photoelastic experiment clearly shows a number of cycloidal teeth constantly in contact with the rollers, thereby distributing the loads. Furthermore, the stress lines clearly shows no stress concentration in the root area. Unlike involute teeth, CYCLO teeth **can not break**.

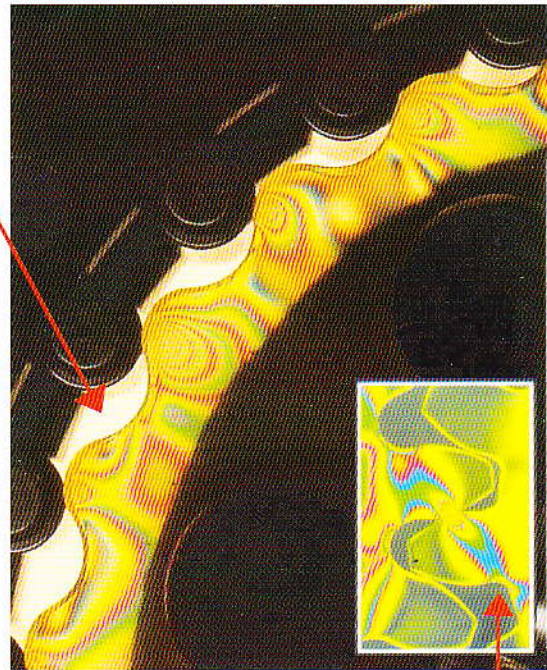
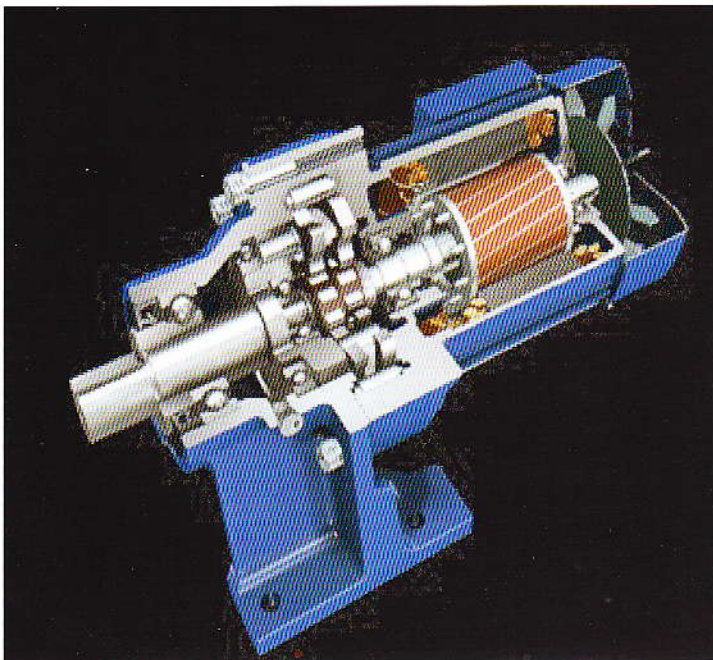

In the involute gear system, only one or two teeth are engaged and are carrying the full load. There is a high stress concentration in the root area of the teeth. Teeth can break under shock load and overload.

### COMPACT IN SIZE

The CYCLO can offer high ratio in a single stage reduction (119/1) thereby making the reducer size more compact and lightweight.

### HIGH EFFICIENCY

The CYCLO can offer ratio up to 119:1 on a single stage reduction at the same time maintaining high efficiency throughout.

### NO CATASTROPHIC FAILURE

Due to the fact that the Cycloidal teeth can not break, there is no chance for the CYCLO to experience catastrophic (Immediate) failure.

### WIDE RATIO RANGE

CYCLO have the ratio range available from 6:1 to 1,000,000:1

### LOW NOISE

As all parts are rolling. CYCLO generate the lowest noise level.

### EASE OF MAINTENANCE

As the disassembled unit shows, Cyclo drive can be easily disassembled and assembled for maintenance using only simple hand tools. Furthermore, the number of parts are less than conventional involute gear system thereby enabling saving on spare parts costs.

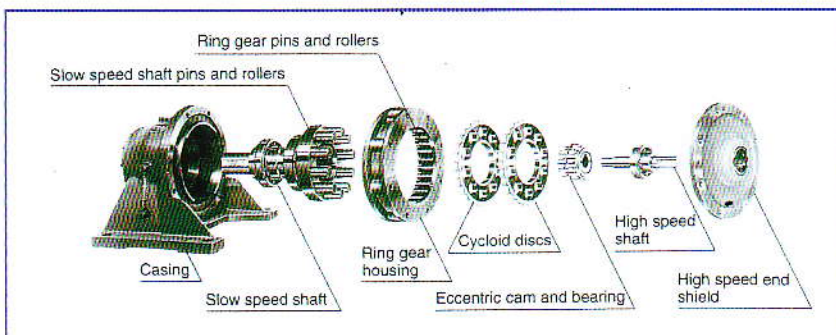



## ADVANTAGE OF CYCLO DRIVE

### HOW IT WORKS

The unique CYCLO speed reducing system is based on an ingeniously simple principle offering many benefits to the designer and user of power transmission drives. Basically, the speed reducer has only three major moving parts:

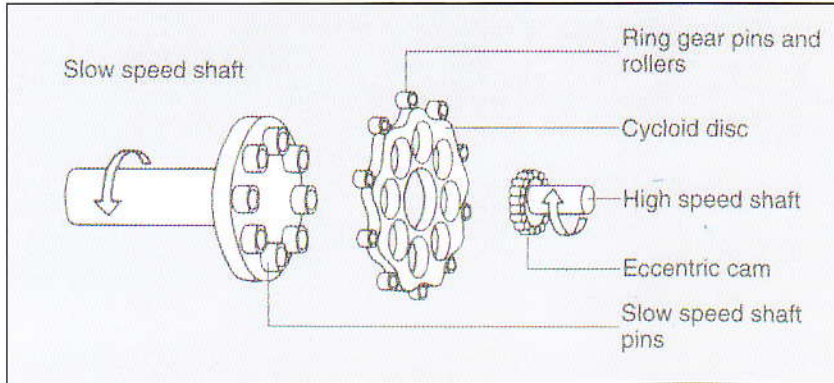

- High speed input shaft with integrally mounted eccentric cam and roller bearing assembly.
- Cycloid discs.
- Slow speed shaft assembly.

As the eccentric cam rotates, it rolls the cycloid discs around the internal circumference of the stationary ring gear. The resulting action is similar to that of a wheel rolling around the inside of a ring. As the wheel (cycloid disc) travels in a clockwise path around the ring (ring gear housing), the wheel itself turns slowly on its own axis in a counter-clockwise direction. In the CYCLO system the cycloidal profile around the outer edge of the disc engages progressively with the rollers of the fixed ring gear housing to produce a reverse rotation at reduced speed. For each complete revolution of the high speed shaft the cycloid disc turns one cycloidal tooth pitch in the opposite direction. In general, there is one less cycloidal tooth around the disc than there are pins in the fixed ring gear housing, which results in reduction ratios being numerically equal to the number of cycloidal teeth on the disc. (Note: On some ratios, there are two less teeth per cycloid disc than there are pins in the ring gear housing.) The reduced rotation of the cycloid discs is transmitted to the slow speed shaft by means of drive pins and rollers which engage with holes located around the middle of each disc. Normally a two disc system is used with a double eccentric cam which increases the torque capacity and offers an exceptionally smooth vibration-free drive.

### ADVANTAGE OF CYCLO-DRIVE

CYCLO-DRIVE	HELICAL GEARS
TWO-THIRDS OF TEETH IN FULL CONTACT ALL TIME  <b>CYCLO SPEED REDUCER</b> Many teeth share the shock of overload.	ONLY 1 OR 2 TEETH IN CONTACT  <b>CONVENTIONAL HELICAL GEAR.</b> 1 or 2 teeth absorb the entire shock of overload.
ROLLING MOTION 	SLIDING FRICTION MOTION 
SHOCK LOAD 500%	SHOCK LOAD ONLY 200%
SMOOTH AND QUIET	NOISY
COMPACT SIZE  <b>COMPACT SIZE</b> Reduction ratios from 6:1 to 119:1 are available for the single stage.	SIZE BIGGER AT THE SAME RATING AND RATIO  Normal ratio of helical gear is 5 or 6

### MOUNTING POSITION

Shaft Position	Mounting	
	Foot Mounting H	V Flange Mounting V
H = Horizontal	CHHM 	CHVM 
V = Vertical Down	CVHM 	CVVM 
W = Vertical Up	CWHM 	CWVM 
N = Universal Mounting Maintenance - Free	CNHM 	CNVM 



## NOMENCLATURE OF GEAR MOTORS

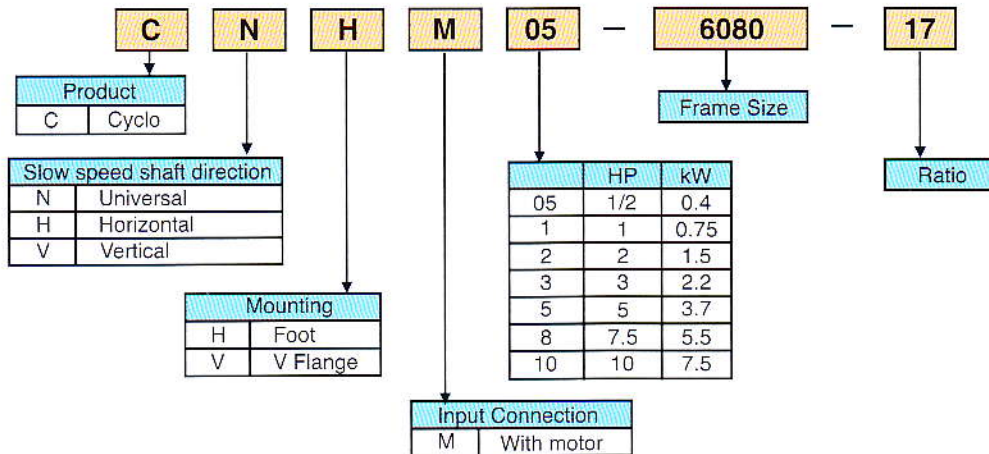

## STANDARD SPECIFICATIONS

Item	Standard Specification	
<b>Motor</b>	Capacity Range	1/2 ~ 10HP 4P
	Enclosure	Totally Enclosed Fan Cooled Type
	Degrees of Protection	IP55
	Voltage and Frequency	- Low Voltage(LT) : 1/2~10HP= 220/380~415V 50Hz, 220/440V 60Hz - High Voltage(HT) : 5~10HP= 380~415V 50Hz, 380~440V 60Hz
	Frame Material	Steel Plate
	Thermal Class	155 (F)
	Rating	S1 (Continuous)
	Connection Type	Terminal Block (6 Leads)
	Connection Diagram	<div style="display: flex; justify-content: space-around;"> <div style="text-align: center;"> <p>Construction of lead wires</p> </div> <div style="text-align: center;"> <p>Connection diagram</p> <div style="display: flex; justify-content: space-around;"> <div style="width: 45%;"> <p>LT</p> </div> <div style="width: 45%;"> <p>HT*</p> </div> </div> </div> </div>
	<b>Cyclo Drive</b>	Lubrication Method
	Speed Reduction Method	Internal planetary gear mechanism with trochoidal curved tooth profile.
<b>Circumstance Condition</b>	Ambient Temperature	-20°C~+40°C
	Ambient Humidity	95% RH or less
	Above Sea Level	1000 m. or less
	Environment	No bursting / erosive gas or vapor
<b>Method of Mounting</b>	<p>CNHM / CHHM type : Slow speed shaft is in horizontal direction and mount horizontally on foot.</p>	

\*HT can be used only with motors 5HP and above.



## STANDARD STOCK OF GEAR MOTOR

### HORIZONTAL TYPE (CNHM/CHHM)

Output Speed (rpm)		MOTOR CAPACITY																				
		1/2 HP (0.4 kW)		S.F.	1 HP (0.75 kW)		S.F.	2 HP (1.5 kW)		S.F.	3 HP (2.2 kW)		S.F.	5 HP (3.7 kW)		S.F.	7.5 HP (5.5 kW)		S.F.	10 HP (7.5 kW)		S.F.
		50 Hz	60 Hz																			
242	292	CNHM05-6080-6	1.48	CNHM1-6090-6	1.53	CNHM2-6100-6	1.57	CNHM3-6110-6	1.61	CNHM5-6120-6	1.37	CHHM8-6130-6	1.71	CHHM10-6135-6	1.51							
132	159	CNHM05-6080-11	1.48	CNHM1-6090-11	1.53	CNHM2-6100-11	1.57	CNHM3-6110-11	1.61	CNHM5-6120-11	1.37	CHHM8-6130-11	1.71	CHHM10-6135-11	1.51							
97	117	CNHM05-6080-15	1.48	CNHM1-6090-15	1.53	CNHM2-6100-15	1.57	CNHM3-6110-15	1.61	CNHM5-6120-15	1.37	CHHM8-6130-15	1.41	CHHM10-6135-15	1.20							
85	103	CNHM05-6080-17	1.48	CNHM1-6090-17	1.53	CNHM2-6100-17	1.33	CNHM3-6110-17	1.45	CNHM5-6125-17	1.53	CHHM8-6135-17	1.51	CHHM10-6145-17	1.60							
69	83	CNHM05-6085-21	1.38	CNHM1-6095-21	2.01	CNHM2-6105-21	1.52	CNHM3-6115-21	1.41	CNHM5-6125-21	1.29	CHHM8-6135-21	1.22	CHHM10-6145-21	1.27							
58	70	CNHM05-6090-25	1.68	CNHM1-6100-25	1.69	CNHM2-6120-25	2.06	CNHM3-6120-25	1.40	CHHM5-6135-25	1.55	CHHM8-6145-25	1.44	CHHM10-6165-25	1.79							
50	60	CNHM05-6090-29	1.56	CNHM1-6100-29	1.61	CNHM2-6120-29	1.91	CNHM3-6125-29	1.58	CHHM5-6135-29	1.31	CHHM8-6145-29	1.37	CHHM10-6165-29	1.52							
41	50	CNHM05-6090-35	1.53	CNHM1-6105-35	1.60	CNHM2-6120-35	1.58	CNHM3-6125-35	1.31	CHHM5-6145-35	1.69	CHHM8-6160-35	1.46	CHHM10-6165-35	1.28							
34	41	CNHM05-6095-43	1.51	CNHM1-6105-43	1.44	CNHM2-6125-43	1.56	CHHM3-6135-43	1.52	CHHM5-6145-43	1.26	CHHM8-6165-43	1.42	CHHM10-6175-43	1.51							

### LUBRICATION

#### Recommended Grease

Ambient temperature (°C)	Model		
	Maintenance-free series	Other grease model	
	Shell	Cosmo Oil	Shell
-10~50	ALVANIA GREASE RA	COSMO GREASE DYNAMAX SH No.2	ALVANIA GREASE 2

#### Recommended Oil

Ambient temperature (°C)	Nisseki Mitsubishi	Idemitsu Kosan	Gulf Oil	Esso Oil	Mobil Oil	Shell Oil	BP Oil
-10~5	Bonnock M 68	Daphe Super Gear Oil 68	EP Lubricant HD 68	Spartan EP 68	Mobil Gear 626 (ISO VG 68)	Omala Oil 68	Energol GR-XP 68
0~35	Bonnock M 100, 150	Daphe Super Gear Oil 100, 150	EP Lubricant HD 100, HD 150	Spartan EP 100, EP 150	Mobil Gear 627 629 (ISO VG 100, 150)	Omala Oil 100, 150	Energol GR-XP 100, GR-XP 150
30~50	Bonnock M 220~460		EP Lubricant HD 220, HD 320, HD 460	Spartan EP 220, EP 320, EP 460	Mobil Gear 630 632, 633 634 (ISO VG 220~460)	Omala Oil 220 320, 460	Energol GR-XP 220, GR-XP 320, GR-XP 460

#### Grease Quantity (litre)

	Frame size	608□	609□	610□	611□	612□
Reduction portion	Qty of grease (g)	65	90	140	200	330
Slow speed shaft bearing portion	Qty of grease (g)	70	100	100	90	120

#### Oil Quantity (litre)

Frame size	613□	614□	616□	617□
Horizontal shaft	0.7	0.7	1.4	1.9



**DIMENSION**

**GEAR MOTOR CNHM / CHHM TYPE**

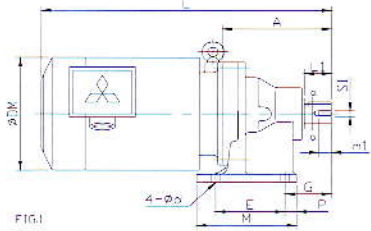

Fig 1. Type CNHM (1/2~2 HP)  
(Grease Lubrication)

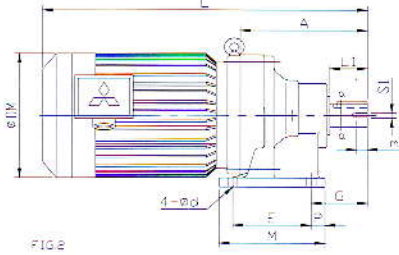

Fig 2. Type CNHM (3~5 HP)  
(Grease Lubrication)

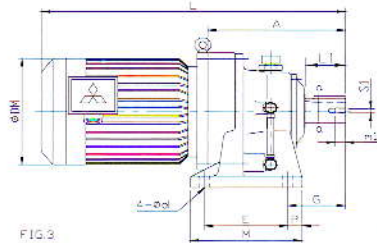
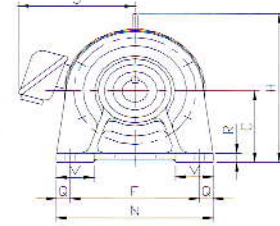
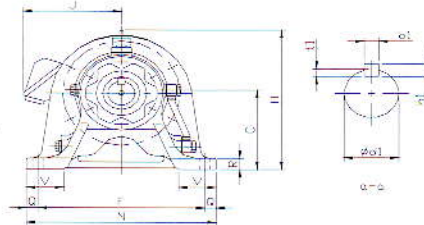

Fig 3. Type CHHM  
(Oil Lubrication)



FRAME SIZE	A	C	E	F	G	M	N	P	Q	R	V	d	SLOW SPEED SHAFT						H	DM	J	L	Weight (kg)	FIG	
													d1	L1	b1	h1	t1	S1							m1
CNHM05-608	129	90	75	120	52	99	144	12	12	13	37	9	22h6 <sup>0</sup> <sub>-0.013</sub>	35	6	6	3.5	M6	16	214.9	147.6	140	328	12	1
CNHM05-609	142	100	90	150	60	135	180	15	15	12	40	11	28h6 <sup>0</sup> <sub>-0.013</sub>	35	8	7	4	M8	20	248.9	147.6	140	345	15	1
CNHM1-609																				248.9	161.6	145	377	19	
CNHM1-610	156	100	90	150	60	135	180	15	15	12	40	11	28h6 <sup>0</sup> <sub>-0.013</sub>	35	8	7	4	M8	20	262.9	161.6	145	391	23	1
CNHM2-610																				215.3	183.6	158	426	31	
CNHM3-611	170	120	90	150	70	135	180	15	15	12	45	11	32h6 <sup>0</sup> <sub>-0.016</sub>	45	10	8	5	M8	20	250.8	207	170	487	38	2
CNHM2-612	186	120	115	190	82	155	230	20	20	15	55	14	38h6 <sup>0</sup> <sub>-0.016</sub>	55	10	8	5	M8	20	250.8	183.6	158	456	41	1
CNHM3-612																				250.8	207	170	503	45	
CNHM5-612																				252.8	228	182	513	55	
CHHM3-613	240	150	145	290	100	195	330	25	20	22	65	18	50h6 <sup>0</sup> <sub>-0.016</sub>	70	14	9	5.5	M10	18	293.8	207	170	557	64	3
CHHM5-613																				295.8	228	182	568	74	
CHHM8-613																				304	266	210	617	84	
CHHM10-613																				304	266	210	617	93	
CHHM5-614	260	150	145	290	120	195	330	25	20	22	65	18	50h6 <sup>0</sup> <sub>-0.016</sub>	90	14	9	5.5	M10	18	305.8	228	182	588	75	3
CHHM8-614																				314	266	210	637	85	
CHHM10-614																				314	266	210	637	94	
CHHM8-616	308	160	150	370	139	238	410	44	20	25	75	18	60h6 <sup>0</sup> <sub>-0.019</sub>	90	18	11	7	M10	18	348.5	266	210	685	120	3
CHHM10-616																				348.5	266	210	685	129	
CHHM10-617	352	200	275	380	125	335	430	30	25	30	80	22	70h6 <sup>0</sup> <sub>-0.019</sub>	90	20	12	7.5	M12	24	403	266	210	729	155	3



**OTHER PRODUCTS**

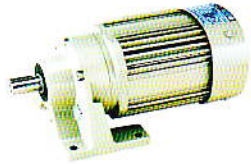

**ALTAx<sup>®</sup> GEAR MOTOR**

Power 90W ~ 2.2 kW  
Ratio 3/1 ~ 1003/1



**ASTERO<sup>®</sup> GEAR MOTOR**

Power 6 ~ 90 W  
Ratio 3/1 ~ 200/1



**CYCLO<sup>®</sup> DRIVE 6000 SERIES**

Power 0.1 ~ 132 kW  
Ratio 6/1 ~ 100000/1

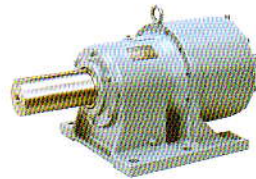

**COMPOWER<sup>®</sup> PLANETARY GEAR**

Torque 150 ~ 75000 kgf.m  
Ratio 5/1 ~ 1768/1

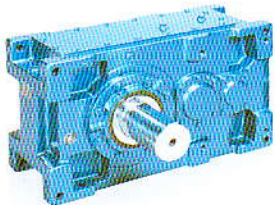

**PARAMAX<sup>®</sup> 9000 SERIES**

Parallel

Torque 260 ~ 52200 kgf.m  
Ratio 6.3/1 ~ 500/1

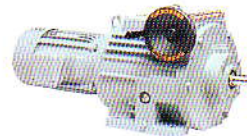

**BEIER<sup>®</sup> VARIATOR**

E series 0.1 ~ 0.75 kW  
Speed range ratio 6/1

NA, A series 0.2 ~ 150 kW  
Speed range ratio 4/1

NB series 0.2 ~ 75 kW  
Speed range ratio 4/1

D series 0.4 ~ 0.75 kW  
Speed range ratio 10/1

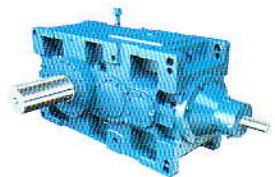

**PARAMAX<sup>®</sup> 9000 SERIES**

Right Angle

Torque 260 ~ 52200 kgf.m  
Ratio 6.3/1 ~ 450/1



**HELICAL<sup>®</sup> BUDDY BOX (HBB)**

Power 0.1 ~ 30 kW  
Ratio 11/1 ~ 26500/1

**HELICAL<sup>®</sup> BUDDY BOX (BBB)**

Power 0.1 ~ 30 kW  
Ratio 11/1 ~ 26500/1

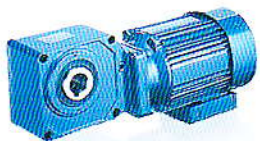
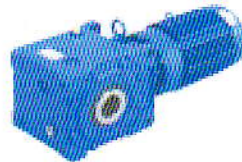
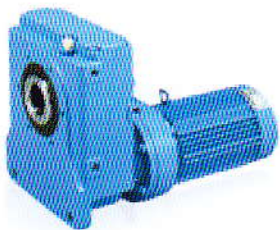

**HYPONIC<sup>®</sup> DRIVE NEO SERIES**

Power 90 W ~ 5.5 kW  
Ratio 5/1 ~ 1440/1

**HSM<sup>®</sup> Shaft Mounted Speed Reducer**

Torque 2.6 ~ 4490 kgf.m  
Ratio 5/1, 13/1, 20/1 25/1



**HYPONIC<sup>®</sup> DRIVE NEO SERIES**

Power 15 ~ 90 W  
Ratio 3/1 ~ 240/1

**HEDCON<sup>®</sup> WORM GEAR**

Solid/Hollow shaft

Torque 60 ~ 8400 kgf.m  
Ratio 5/1 ~ 100/1

